



# LINEAR GUIDEWAYS

Accessories

**Germany**

HIWIN GmbH  
Brücklesbünd 1  
77654 Offenburg  
Deutschland  
Fon +49 781 93278-0  
info@hiwin.de  
hiwin.de

**Taiwan**

Headquarters  
HIWIN Technologies Corp.  
No. 7, Jingke Road  
Precision Machinery Park  
Taichung 40852  
Táiwān  
Fon +886 4 2359-4510  
business@hiwin.tw  
hiwin.tw

**Taiwan**

Headquarters  
HIWIN Mikrosystem Corp.  
No. 6, Jingke Central Road  
Precision Machinery Park  
Taichung 40852  
Táiwān  
Fon +886 4 2355-0110  
business@hiwinmikro.tw  
hiwinmikro.tw

**France**

HIWIN SAS  
Le Mélèze  
17 Rue des Cigognes  
67960 Entzheim  
France  
Fon +33 3 882884-80  
contact@hiwin.fr  
hiwin.fr

**Poland**

HIWIN GmbH Biuro Warszawa  
ul. Puławska 405a  
02-801 Warszawa  
Polska  
Fon +48 22 46280-00  
info@hiwin.pl  
hiwin.pl

**Denmark**

HIWIN GmbH  
info@hiwin.dk  
hiwin.dk

**Netherlands**

HIWIN GmbH  
info@hiwin.nl  
hiwin.nl

**Austria**

HIWIN GmbH  
info@hiwin.at  
hiwin.at

**Hungary**

HIWIN GmbH  
info@hiwin.hu  
hiwin.hu

**Czech Republic**

HIWIN s.r.o.  
Medkova 888/11  
62700 Brno  
Česká republika  
Fon +42 05 48528-238  
info@hiwin.cz  
hiwin.cz

**Bulgaria**

HIWIN Bulgaria  
Christopher Columbus No. 4  
1582 Sofia  
Bulgaria  
Fon +35 92 999 52 45  
info@hiwin.bg  
hiwin.bg

**Slovakia**

HIWIN s.r.o., o.z.z.o.  
Mládežnícka 2101  
01701 Považská Bystrica  
Slovensko  
Fon +421 424 4347-77  
info@hiwin.sk  
hiwin.sk

**Switzerland**

HIWIN [Schweiz] GmbH  
Eichwiesstrasse 20  
8645 Jona  
Schweiz  
Fon +41 55 22500-25  
sales@hiwin.ch  
hiwin.ch

**Italy**

HIWIN Srl  
Via Pitagora 4  
20861 Brugherio (MB)  
Italia  
Fon +39 039 28761-68  
info@hiwin.it  
hiwin.it

**Romania**

HIWIN Srl  
info@hiwin.ro  
hiwin.ro

**Slovenia**

HIWIN Srl  
info@hiwin.si  
hiwin.si

**China**

HIWIN Corp.  
hiwin.cn

**Japan**

HIWIN Corp.  
info@hiwin.co.jp  
hiwin.co.jp

**USA**

HIWIN Corp.  
info@hiwin.com  
hiwin.us

**Korea**

HIWIN Corp.  
hiwin.kr

**Singapore**

HIWIN Corp.  
hiwin.sg

# LINEAR GUIDEWAYS

## Linear guideways & accessories

A linear guideway makes it possible to move in a linear motion with rolling elements. The use of balls and rollers between the rail and block in a linear guideway makes precise linear movements possible. Compared with a standard sliding guide, the friction coefficient here is just one fiftieth. The high efficiency and zero backlash mean that the linear guideway can be used in various ways.

## DOWNLOADS AND APPLICATIONS

Assembly instructions

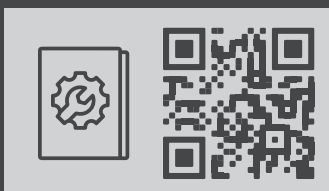

Sizing tool

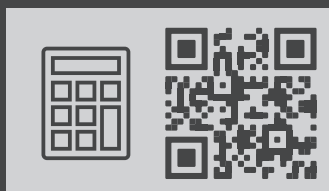

CAD configurator

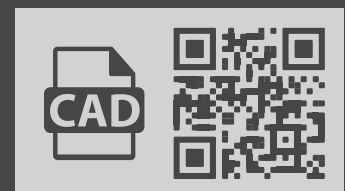

# Linear guideways

Contents

---

**Contents**

1.	Product overview .....	6
2.	General information .....	10
2.1	Properties and advantages	10
2.2	Selection principles	11
2.3	Load ratings	12
2.4	Service life calculation	13
2.5	Operating load	15
2.6	Friction and lubrication	17
2.7	Installation position	18
2.8	Assembly	19
2.9	Sealing systems	24
2.10	SynchMotion™ technology	26
2.11	Heat-resistant linear guideways	27
2.12	Corrosion-resistant linear guideways	28
3.	Linear guideways: Series .....	34
3.1	HG/QH series	34
3.2	CG series	52
3.3	EG/QE series	70
3.4	WE/QW series	84
3.5	RG/QR series	96
3.6	CRG series	114
3.7	MG series	130
3.8	PG series	144
4.	Accessories .....	152
4.1	Lubrication adapter	152
4.2	Grease guns and lubricants	153

# Linear guideways

## Product overview

### 1. Product overview

#### Ball bearing slides

Ball bearing slides are used in areas such as automation, handling, woodworking and laser cutting machines. They are characterised by their high load capacity and high rigidity. Select the right series for your requirements here. Alternatively, you can configure your suitable linear guide with the appropriate accessories directly in our product configurator. CAD data and technical drawings are also available for download here.

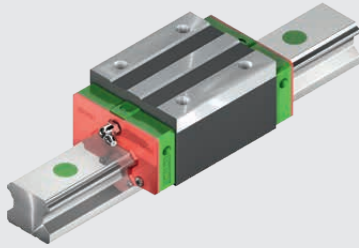

#### Linear guideway of HG and QH series

Page 34

- Standard series in X arrangement (First choice for rail pair applications)
- Block with SynchMotion™ technology (QH series)
- Optionally available in corrosion-resistant steel (HG15, HG20 and HG25)

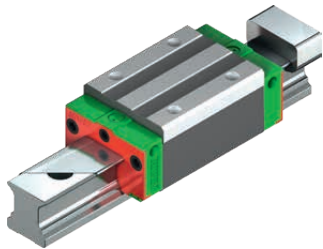

#### Linear guideway CG series

Page 52

- Standard series in O arrangement (First choice for single-rail applications)
- Optional: Rail with cover strip

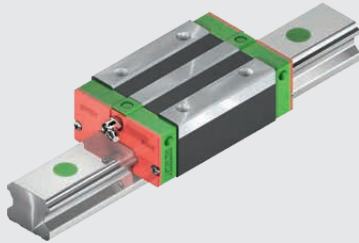

#### Linear guideway of EG and QE series

Page 70

- Flat type (Especially for applications with limited installation space)
- Block with SynchMotion™ technology (QE series)

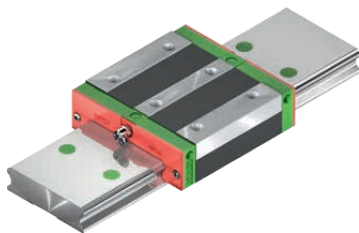

#### Linear guideway of WE and QW series

Page 84

- Wide type (Specifically for applications with high torque loads)
- Block with SynchMotion™ technology (QW series)

## Roller guides

Roller guides are mainly used in heavy-duty solutions, such as in machine tools, presses, injection moulding machines or measuring machines. They are characterised by their very high load capacity and very high rigidity. Select the right series for your requirements here. Alternatively, you can configure your suitable linear guide with the appropriate accessories directly in our product configurator. CAD data and technical drawings are also available for download here.

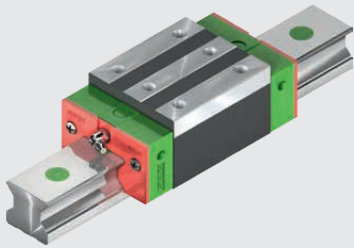

### Linear guideway of RG and QR series

Page 96

- Roller guides for heavy-duty applications
- With maximum requirements on load capacity and torque capacity
- Block with SynchMotion™ technology (QR series)

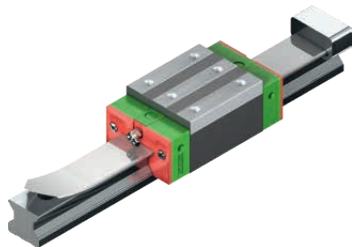

### Linear guideway CRG series

Page 114

- Roller guides with cover strip for heavy-duty applications
- With maximum requirements on load capacity and torque capacity
- Rail with cover strip

## Miniature guideways

Miniature guides are used in medical technology, microelectronics, the optical industry, measuring devices and 3D printing. Their compact and lightweight design makes them particularly suitable for use in small devices. The Gothic running surface profile ensures uniform load absorption from all directions. All steel parts in our miniature series are made of corrosion-resistant martensitic steel as standard in the HIRES type. Select the right series for your requirements here. Alternatively, you can configure your suitable miniature guide with the appropriate accessories directly in our product configurator. CAD data and technical drawings are also available for download here.

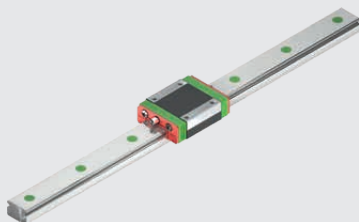

### Linear guideway MG series

Page 130

- Thin and wide design
- Miniature type for the most compact applications
- Dual-row linear guideways
- Made of corrosion-resistant steel as standard

# Linear guideways

## Product overview

### Integrated distance measuring system

Linear guideways with an integrated magnetic distance measuring system are optimised for measuring linear movements. Compactly integrated, the encoder is attached to the block and the measuring tape is inserted into the profile rail protected by the cover strip. With electrical shielding and real-time signal output, our linear guides with MAGIC distance measuring system are used in automation, handling or in axes with direct distance measurement, such as linear motor axes. Select the right series for your requirements here or configure your linear guide with integrated distance measuring system directly in our product configurator. CAD data and technical drawings are also available for download here.

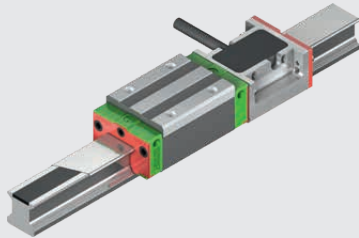

#### Linear guideway PG series

Page 144

- CG series with integrated magnetic positioning measuring system
- Contactless positioning measurement
- Signal output in real time



# Linear guideways

## General information

---

## 2. General information

### 2.1 Properties and advantages

#### 1. High positioning accuracy

A carriage supported by a linear guideway only has to overcome rolling friction. The difference between static and dynamic rolling friction is very small, which means that the breakaway force is only slightly higher than the moving force. No stick-slip effects occur.

#### 2. Long service life with particularly precise movement

With a sliding guide, errors in accuracy can occur due to different lubricant film thicknesses. Due to the sliding friction and frequent lack of lubrication, high wear and thus decreasing accuracy occurs. In contrast, the linear guideway has the advantage of very low rolling friction, combined with extremely low wear. The guideway accuracy remains almost constant over the entire service life.

#### 3. High velocity with low drive force

Due to the low friction coefficient, only low drive forces are required. The required drive power remains low even with reversing movements.

#### 4. Equal load capacity in all directions

Due to the design-related forced guidance, a linear guideway can absorb forces in vertical and horizontal directions.

#### 5. Simple installation and interchangeability

Installing a linear guideway is simple. With a milled or ground mounting surface, high accuracy is achieved when assembly instructions are followed. Conventional sliding guides require considerably more assembly work due to scraping of the sliding surfaces. Replacing individual components is not possible without scraping. However, linear guideways can be replaced without further effort.

#### 6. Simple lubrication

With sliding guides, insufficient lubrication leads to destruction of the sliding surfaces. The lubricant must be supplied to the sliding surfaces at many points. The linear guideway requires only minimum lubrication, which is produced by a simple supply line to the block. As a variant, HIWIN also supplies blocks with an integrated and replaceable long-term lubrication unit, which ensures long-term lubrication.

#### 7. Corrosion protection

Blocks and profile rails can be supplied with various coatings to achieve optimum corrosion protection. The individual processes are selected depending on the application. For optimal selection of the coating, data on the environmental conditions and the corrosive substances is needed. Linear guideways are available in various materials and coatings for different requirements and applications.



# Linear guideways

## General information

### 2.3 Load ratings

#### 2.3.1 Static load rating $C_0$

If a linear guideway system is subjected to excessive loads or impacts during movement or at a standstill, localised permanent deformation occurs between the track and balls. As soon as this permanent deformation exceeds a certain level, it affects smooth operation of the guideway. According to its basic definition, the static load rating corresponds to a static load that causes permanent deformation of  $0.0001 \times$  ball diameter at the contact point that is loaded the most. The values are given in the

tables for each linear guideway system. Using these tables, the designer can select a suitable linear guideway system. The maximum static load to which a linear guideway system is subjected must not exceed the static load rating.

#### 2.3.2 Permissible static moment $M_0$

The permissible static moment is the moment which, in a defined direction and size, corresponds to the maximum possible load on the moving parts by the basic static load rating. The permissible static moment is defined for linear motion systems for three directions:  $M_x$ ,  $M_y$  and  $M_z$ .

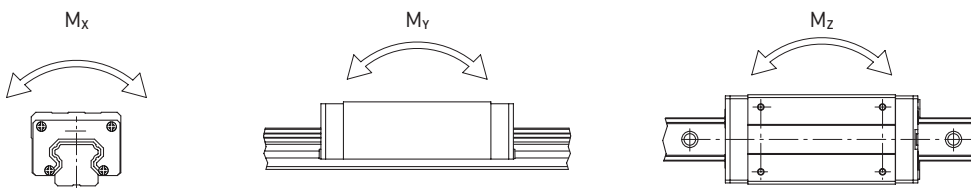

#### 2.3.3 Static support stability

For profile rail systems at rest and slow motion, the static support stability must be taken into account, which depends on the environmental and operating conditions. Increased support stability is particularly important for guideways that are subjected to impact loads, see Table 2.1. The static support stability can be calculated according to F 2.1.

#### F 2.1

$$f_{SL} = \frac{C_0}{P} ; f_{SM} = \frac{M_0}{M}$$

$f_{SL}$	Static support stability
$f_{SM}$	Static support stability for torque load
$C_0$	Static load rating [N]
$M_0$	Permissible static moment [Nm]
$P$	Static equivalent load [N]
$M$	Static equivalent moment [Nm]

**Note:** The linear guideway's load-bearing capacity is often restricted – not by its load-bearing strength, but by the screw connection. We therefore recommend checking the screw connection's maximum permissible load-bearing capacity in accordance with VDI 2230.

Load	$f_{SL}; f_{SM}$ [min.]
Normal load	1.25 – 3.00
With jolting and vibration	3.00 – 5.00

#### 2.3.4 Dynamic load rating $C_{dyn}$

The dynamic load rating is the load, defined in terms of direction and size, at which a linear guideway achieves a nominal service life of a 50 km<sup>1)</sup> (HG, QH, EG, QE, CG, WE, QW, MG) or 100 km<sup>1)</sup> (RG, QR) travel path. The dynamic load rating is specified for each guideway in the dimension tables. It can be used to calculate the service life of a particular guideway.

<sup>1)</sup> The dynamic load rating of linear guideways is specified for a service life of a 50 or 100 km travel path, depending on the manufacturer. The following factors can be used to convert the basic dynamic load rating:  $C_{dyn} 50 \text{ km} = 1.26 \times C_{dyn} 100 \text{ km}$  (HG, QH, EG, QE, CG, WE, QW, MG series)  
 $C_{dyn} 50 \text{ km} = 1.23 \times C_{dyn} 100 \text{ km}$  (RG, QR series)

## 2.4 Service life calculation

### 2.4.1 Definition of service life

The constant and repeated loading of tracks and balls of a linear guideway causes fatigue on the track surface. In the end, so-called pitting formation occurs.

The service life of a linear guideway is defined as the total travel distance covered until pitting occurs on the surface of the track or balls.

### 2.4.2 Nominal service life (L)

The service life can be very different even if linear guideways are manufactured in the same way and used under the same movement conditions. Therefore, the nominal service life is taken as a reference value for estimating the service life of a linear guideway.

The nominal service life corresponds to the total travel path achieved without failure by 90% of a group of identical linear guideways used under the same conditions.

#### 2.4.2.1 Calculation of the nominal service life

The actual load influences the nominal service life of a linear guideway. Using the selected dynamic load rating and the equivalent dynamic load, the nominal service life can be calculated using the formulas F 2.2 and F 2.3.

#### Formulas for calculation of the nominal service life

HG, QH, EG, QE, CG, WE, QW, MG series:

$$F 2.2 \quad L = \left( \frac{C_{dyn}}{P} \right)^3 \times 50 \text{ km}$$

L Nominal service life [km]  
 $C_{dyn}$  Dynamic load rating [N]  
 P Dynamic equivalent load [N]

RG, QR series:

$$F 2.3 \quad L = \left( \frac{C_{dyn}}{P} \right)^{10/3} \times 100 \text{ km}$$

#### 2.4.2.2 Factors of nominal service life

The type of load, the hardness of the track and the temperature of the guideway have a considerable influence on the nominal service life. The relationship between these factors are shown by formulas F 2.4 and F 2.5.

##### Hardness factor ( $f_h$ )

The tracks of the linear guideways have a hardness of 58 HRC. A hardness factor of 1.0 therefore applies. If the hardness differs, the hardness factor according to the adjacent figure must be taken into account. If the specified hardness is not achieved, the permissible load is reduced. In this case, the dynamic load rating and the static load rating must be multiplied by the hardness factor.

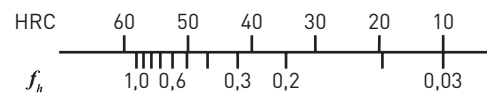

##### Temperature factor ( $f_t$ )

The application range of the standard profile rails is between -10 and 80 °C ambient temperature. For ambient temperatures up to 150 °C, the use of linear guideways with steel deflection system is required (marked with the suffix "SE" in the order code). Short-term ambient temperatures of up to 180 °C are possible. However, we recommend consulting our technical support for this. If the temperature of a linear guideway exceeds 100 °C, the permissible load and the service life are reduced. That is why the dynamic load rating and the static load rating must be multiplied by the temperature factor.

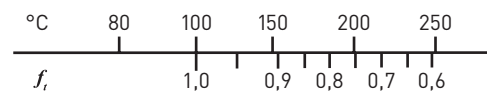

# Linear guideways

## General information

### Load factor ( $f_w$ )

To take into account external influences on the service life of the profile rails which are not directly included in the calculation (e.g. vibrations, jolting and high speed), the dynamic equivalent load is multiplied by the load factor according to Table 2.2. For short-stroke applications (stroke < 2 × block lengths), the calculated load factor must be doubled.

Type of load	Travel speed	$f_w$
No jolting and vibration	At 15 m/min	1.0 – 1.2
Normal load	15 m/min – 60 m/min	1.2 – 1.5
Minor jolting	60 m/min – 120 m/min	1.5 – 2.0
With jolting and vibration	Greater than 120 m/min	2.0 – 3.5

### Formulas for calculation of the nominal service life (considering all factors)

HG, QH, EG, QE, CG, WE, QW, MG series:

$$F 2.4 \quad L = \left( \frac{f_h \times f_t \times C_{dyn}}{f_w \times P} \right)^3 \times 50 \text{ km}$$

L Nominal service life [km]  
 $f_h$  Hardness factor  
 $C_{dyn}$  Dynamic load rating [N]  
 $f_t$  Temperature factor  
 P Dynamic equivalent load [N]  
 $f_w$  Load factor

RG, QR series:

$$F 2.5 \quad L = \left( \frac{f_h \times f_t \times C_{dyn}}{f_w \times P} \right)^{10/3} \times 100 \text{ km}$$

### 2.4.3 Service life ( $L_h$ )

The service life in hours is calculated from the nominal service life with the aid of the travel speed and movement frequency.

### Formulas for calculation of the service life ( $L_h$ )

HG, QH, EG, QE, CG, WE, QW, MG series:

$$F 2.6 \quad L_h = \frac{L}{v \times 60} = \frac{\left( \frac{C_{dyn}}{P} \right)^3 \times 50.000}{v \times 60}$$

$L_h$  Service life [h]  
 L Nominal service life [m]  
 v Velocity [m/min]  
 $C_{dyn}/P$  Load rating/Load ratio

RG, QR series:

$$F 2.7 \quad L_h = \frac{L}{v \times 60} = \frac{\left( \frac{C_{dyn}}{P} \right)^{10/3} \times 100.000}{v \times 60}$$

## 2.5 Operating load

### 2.5.1 Calculation of load

When calculating the loads acting on a linear guideway, various factors must be taken into account, e.g. the centre of gravity of the load, the approach of the movement force and the mass inertia at the beginning and end of the movement. To obtain a correct value, each parameter must be taken into account.

#### Load on a block

Table 2.3 Examples of the calculation of the load on a block		
Typical examples	Load distribution	Load on a block
		$P_1 = \frac{W}{4} + \frac{F}{4} + \frac{F \times a}{2c} + \frac{F \times b}{2d}$ $P_2 = \frac{W}{4} + \frac{F}{4} + \frac{F \times a}{2c} - \frac{F \times b}{2d}$ $P_3 = \frac{W}{4} + \frac{F}{4} - \frac{F \times a}{2c} + \frac{F \times b}{2d}$ $P_4 = \frac{W}{4} + \frac{F}{4} - \frac{F \times a}{2c} - \frac{F \times b}{2d}$
		$P_1 = P_3 = \frac{F \times l}{2d}$ $P_2 = P_4 = \frac{W}{4} + \frac{F \times l}{2d}$
		$P_1 = P_2 = P_3 = P_4 = -\frac{W \times h}{2d} + \frac{F \times l}{2d}$
		$P_1 = P_2 = -\frac{W \times h}{2c} - \frac{F \times l}{2c}$ $P_3 = P_4 = \frac{W \times h}{2c} + \frac{F \times l}{2c}$ $P_{t1} = P_{t3} = \frac{W}{4} + \frac{F}{4} + \frac{F \times k}{2d}$ $P_{t2} = P_{t4} = \frac{W}{4} + \frac{F}{4} - \frac{F \times k}{2d}$

$P_1 \dots P_4$  Load on a single block

W Weight of load

F Movement force; additionally occurring force

l Lever arm F

c Rail distance

d Block distance

a, b, k Distance to centre of gravity

h Lever arm centre of gravity W

# Linear guideways

## General information

### Load and mass inertia

Consideration of acceleration and braking	Load on a block
	<p>- Constant velocity</p> $P_1 \dots P_4 = \frac{W}{4}$ <p>- Acceleration</p> $P_1 = P_3 = \frac{W}{4} + \frac{1}{2} \times \frac{W}{g} \times \frac{v_c}{t_1} \times \frac{l}{d}$ $P_2 = P_4 = \frac{W}{4} - \frac{1}{2} \times \frac{W}{g} \times \frac{v_c}{t_1} \times \frac{l}{d}$ <p>- Braking</p> $P_1 = P_3 = \frac{W}{4} - \frac{1}{2} \times \frac{W}{g} \times \frac{v_c}{t_3} \times \frac{l}{d}$ $P_2 = P_4 = \frac{W}{4} + \frac{1}{2} \times \frac{W}{g} \times \frac{v_c}{t_3} \times \frac{l}{d}$

$P_1 \dots P_4$  Load on a single block [N]

W Weight of load [N]

F Movement force

$F_A$  Reaction force

g Gravitational acceleration [ $m/s^2$ ]

$v_c$  Velocity [m/s]

$t_1$  Acceleration time [s]

$t_2$  Constant travel time [s]

$t_3$  Braking time [s]

c Rail distance [m]

d Block distance [m]

l Distance to underside of rail – travel block centre of gravity [m]

### 2.5.2 Calculation of the equivalent load for variable loads

If the load on a linear guideway varies greatly, an equivalent load must be included in the calculation of the service life. The equivalent load is defined as the load that causes the same wear on the bearings as the variable loads. It can be calculated according to Table 2.5.

Step-wise change	Uniform change	Sinusoidal change
$P_m = \sqrt[3]{\frac{1}{L} (P_1^3 \times L_1 + P_2^3 \times L_2 + \dots + P_n^3 \times L_n)}$	$P_m = \frac{1}{3} (P_{min} + 2 \times P_{max})$	$P_m = 0,65 \times P_{max}$

$P_m$  Equivalent load

$P_n$  Variable load

$P_{min}$  Smallest load

$P_{max}$  Largest load

L Total travel path

$L_n$  Travel path with load  $P_n$

## 2.6 Friction and lubrication

### 2.6.1 Frictional resistance

The use of rolling elements in the linear guideway essentially reduces the friction to the rolling friction of the rolling elements. The friction coefficient of linear guideways is thus very small, up to one fiftieth of the value of traditional sliding guides. In general, the friction coefficient is about 0.004, depending on the series. If the load is only 10% or less of the basic dynamic load rating, most of the frictional resistance is

generated by the wipers and by the grease and friction between the rolling elements. If the operating load becomes greater than 10% of the dynamic load rating, the load provides most of the frictional resistance.

**F 2.8**  $F = \mu \times W + S$

F	Frictional force [N]
S	Frictional resistance [N]
$\mu$	Friction coefficient
W	Load [N]

### 2.6.2 Lubrication

The linear guideways, like all rolling bearings, require adequate lubrication. Both grease and oil may be used in general. The lubricant is a constructional element and should be taken into consideration when designing a machine. The lubricants reduce wear, protect against dirt, reduce corrosion and lengthen service life. Dirt can settle and solidify on unprotected profile rails. This dirt must be removed on a regular basis.

For wall mounting, we generally recommend grease or low-viscosity lubricant; for oil lubrication, we generally ask that you consult us, as insufficient lubrication may occur depending on the installation position.

HIWIN offers greases for different requirements:

- HIWIN G01: Heavy-duty applications
- HIWIN G02: Clean room and vacuum applications
- HIWIN G03: Clean room and vacuum applications with high velocities
- HIWIN G04: Applications with high speeds
- HIWIN G05: Standard applications
- HIWIN G06: Short stroke and high frequency applications
- HIWIN G07: Applications at low temperatures

Information on HIWIN lubricants can be found in the Accessories chapter on Page 153. Detailed information on HIWIN lubricants and lubrication of the linear guideways can be found in the **"Linear guideways"** assembly instructions at [hiwin.de](http://hiwin.de).

### 2.6.3 Long-term lubrication unit

The long-time lubrication unit considerably increases lubrication intervals. Depending on the application and ambient conditions, it can achieve lifetime lubrication. It also considerably reduces lubricant consumption, as only the required quantity of lubricant is applied.

The long-time lubrication unit can be used at ambient temperatures of -10 °C to +60 °C.

The compact construction and special design allows the block to be fitted in any position without impairing the lubrication function.

The long-time lubrication units are available for the HG/QH, CG, EG/QE, MG and RG series. The corresponding dimensions and the running performance can be found in the chapter of the corresponding series. HG/QH series: Page 34, CG series: Page 52, EG/QE series: Page 70, MG series: Page 130, RG series: Page 96.

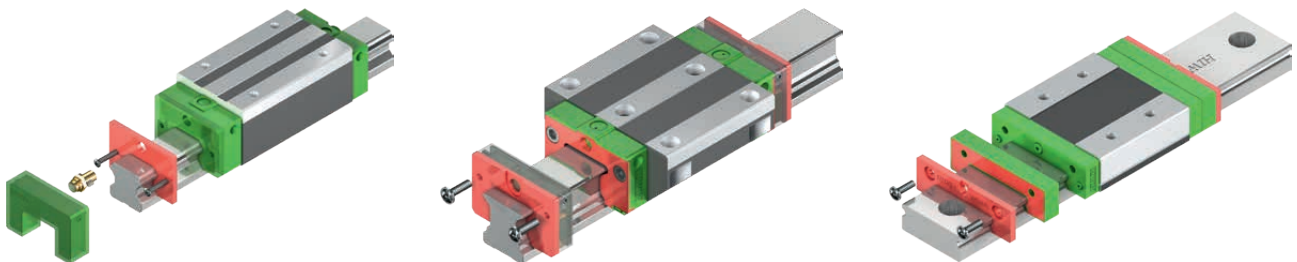

### Applications

- Machine tools
- Production machines: Injection moulding machines, paper industry, textile machines, food industry, woodworking machines
- Electronics industry: Semiconductor industry, robotics, cross tables, measuring and testing machines
- Other areas: Medical equipment, automation, handling technology

# Linear guideways

## General information

### 2.7 Installation position

#### 2.7.1 Examples of typical installation positions

A linear guideway can take loads up/down and to the right/left. The installation position depends on the requirements of the machine and the load direction. The accuracy of the profile rail is determined by how straight and level the contact surfaces are because the profile rail is pressed against them when the screws are tightened. Profile

rails that are not pressed against a contact surface may have greater tolerances in terms of straightness. The typical installation positions are shown below: Information on mounting tolerances is given in the chapters of the individual series.

#### A profile edge at a reference edge:

The reference edge is marked by arrows on the top of the rail. For very short rail sections, the marking is on the front side of the rail.

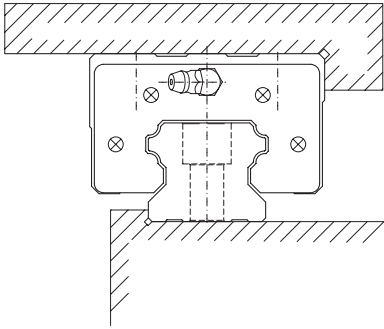

#### Two profile rails with moving block:

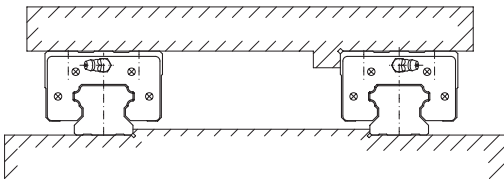

#### Two profile rails with fixed block:

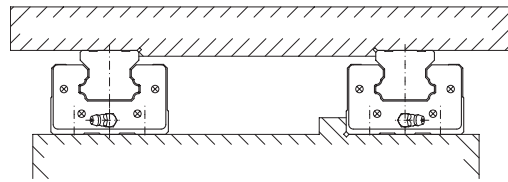

#### Two external blocks:

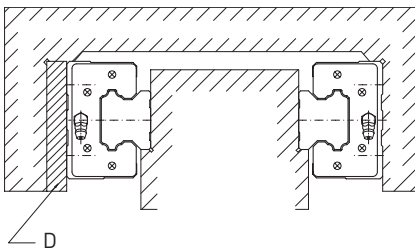

#### Two internal blocks:

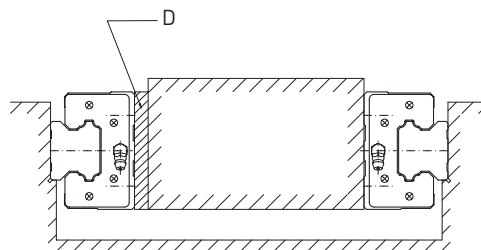

#### Structure with assembled surface:

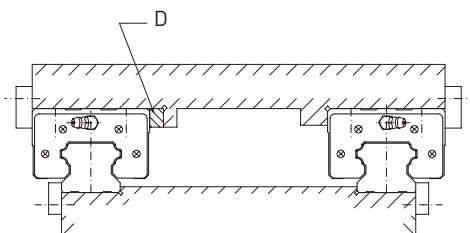

#### Block model HGW\_C with different mounting directions:

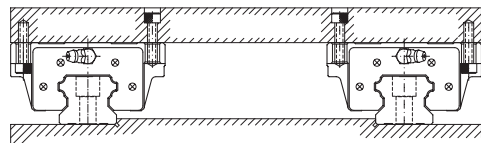

D Spacer

## 2.8 Assembly

Depending on the required accuracy as well as the load on the linear guideway caused by jolting and vibrations, the following three mounting methods are recommended.

### 2.8.1 Mounting the profile rails with reference edge and clamps

If the machine is subjected to strong vibrations, jolting or lateral forces, guideways and blocks may shift. To avoid this problem and to achieve high rigidity and guiding accuracy, mounting the linear guideway with reference edges and clamps on both sides is recommended.

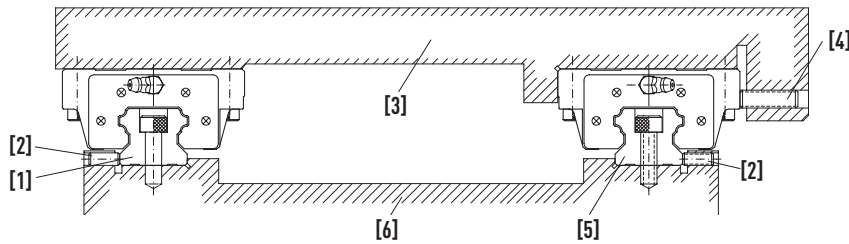

- [1] Follow-on side
- [2] Guide clamping screw
- [3] Carriage
- [4] Block clamping screw
- [5] Reference side
- [6] Machine bed

#### 2.8.1.1 Mounting types

The following four mounting types are recommended.

##### Mounting with a clamping plate:

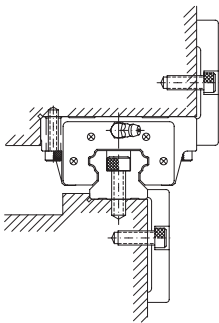

##### Mounting with clamping screws:

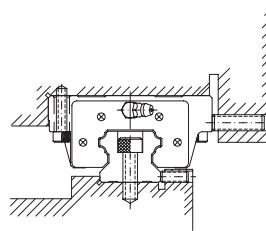

##### Mounting with terminal blocks:

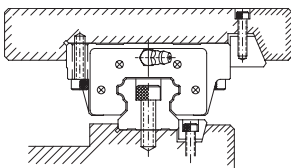

##### Mounting with needle rollers:

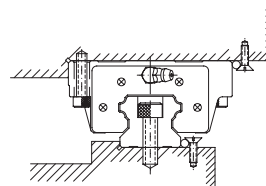

# Linear guideways

## General information

### 2.8.1.2 Assembly of the profile rails

1) Before starting, remove all dirt from the surface of the machine

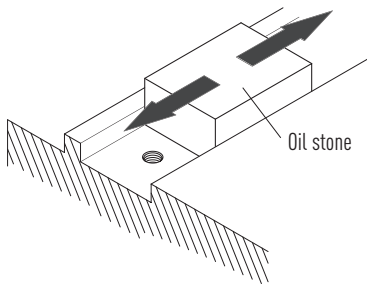

2) Carefully place the profile rail on the bed and hold it firmly against the reference edge

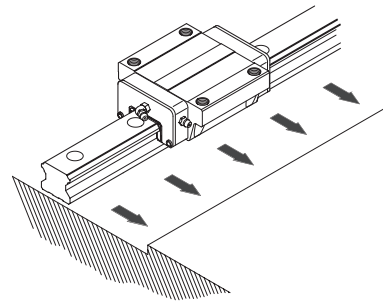

3) When aligning the profile rail on the bed, check whether the threads of the inserted screws engage

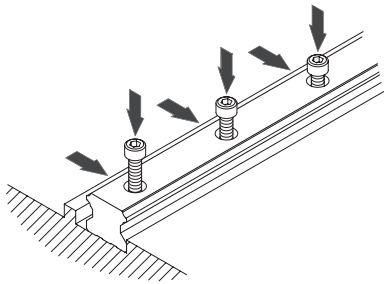

4) Tighten clamping screws one after the other to ensure good contact between the profile rail and the reference edge

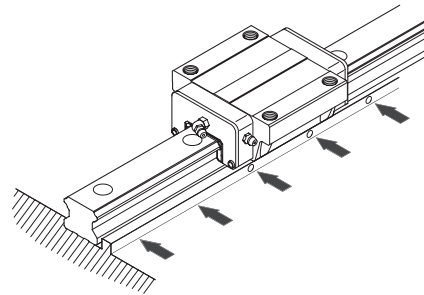

5) Working in three steps, tighten all rail fixing screws to the specified tightening torque using a torque spanner

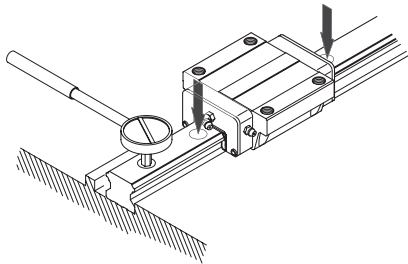

6) Mount the second profile rail in the same way

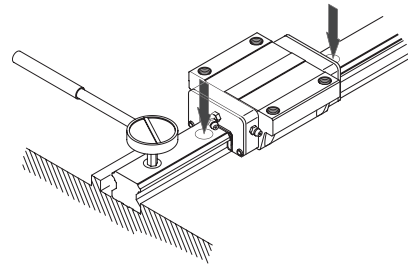

### 2.8.1.3 Mounting the block

- Carefully place carriage on the block. Then temporarily tighten the carriage fixing screws.
- Press the block against the reference edge of the carriage and align the carriage by tightening the clamping screws.
- To mount the carriage evenly, tighten the fixing screws on the reference side and the follow-on side in four passes.

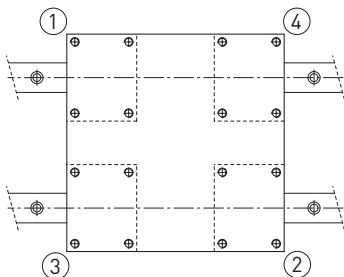

## 2.8.2 Mounting the profile rails with reference edge and without clamps

To ensure parallelism between the reference and follow-on rail without clamping screws, the following methods are recommended for mounting. The installation of the block remains as previously described.

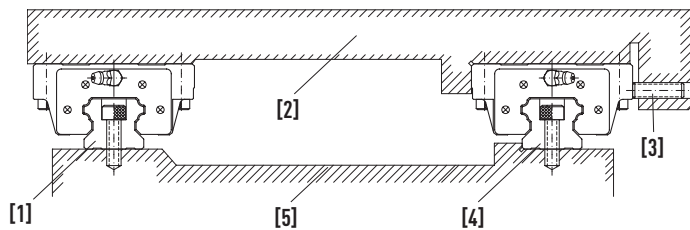

- [1] Follow-on rail
- [2] Carriage
- [3] Block clamping screw
- [4] Reference rail
- [5] Machine bed

### 2.8.2.1 Mounting the profile rail on the reference side

Place the guideway on the mounting surface of the machine bed. Lightly tighten the fixing screws and then press the guideway against the reference edge of the machine bed using a screw clamp. Then tighten the fixing screws one after the other to the specified torque.

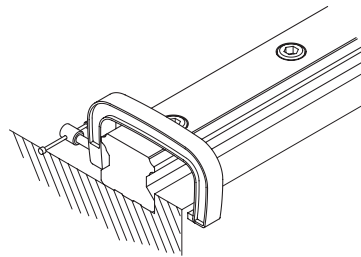

### 2.8.2.2 Mounting the profile rail on the follow-on side

#### Align to a ruler:

Place the ruler between the guideways and align it parallel to the reference edge on the reference side using a dial gauge. When the guideway on the follow-on side is aligned parallel to the reference side, tighten the fixing screws one after the other, working from one end of the guideway to the other.

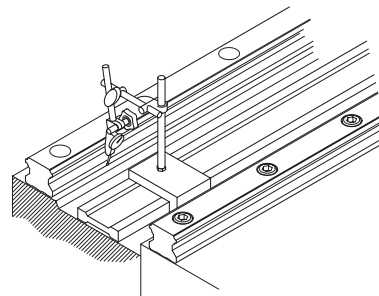

#### With the help of a plate:

Mount a plate on two blocks on the reference rail. Loosely attach a block to the plate to the follow-on rail. Then attach a dial gauge to the plate and place the sensor on the side of the block of the follow-on rail. Then move the plate from one end to the other and align the follow-on rail parallel to the reference rail. Then tighten the fixing screws one after the other.

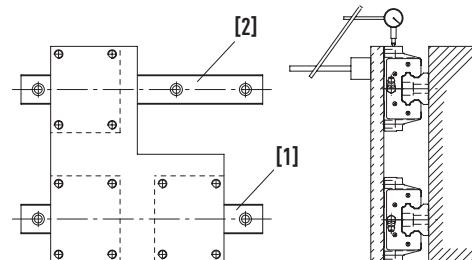

- [1] Reference rail
- [2] Follow-on rail

# Linear guideways

## General information

### Alignment on the reference rail:

When the reference rail is correctly installed, mount one plate firmly on two blocks on the reference rail and one of the two blocks on the follow-on rail. Then move the plate from one end of the rails to the other, tightening the fixing screws of the follow-on rail.

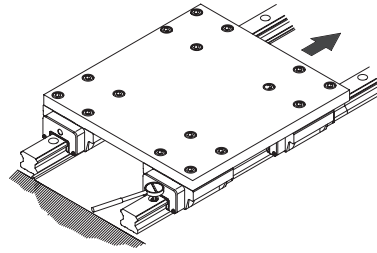

### With the help of a gauge:

Determine the position of the follow-on rail using a special gauge and tighten the fixing screws with the specified torque.

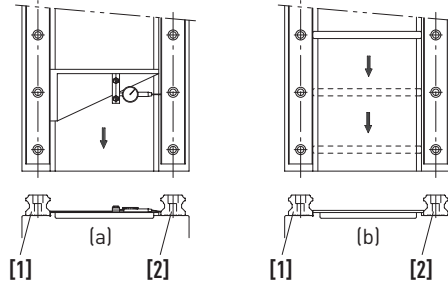

- [1] Reference rail
- [2] Follow-on rail

### 2.8.3 Mounting the profile rails without reference edge and without clamps

To ensure parallelism of the reference and follow-on rail even without a reference edge on the reference side, the following type of mounting is recommended. Mounting of the block remains as previously described.

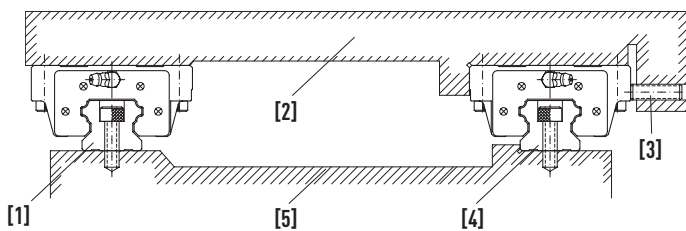

- [1] Follow-on rail
- [2] Carriage
- [3] Block clamping screw
- [4] Reference rail
- [5] Machine bed

#### 2.8.3.1 Mounting the profile rail on the reference side

##### Alignment at a provisional reference edge:

Connect two blocks close together with a plate. Use an edge on the machine bed to align the rail from one end to the other. Move the block to test and then tighten the fixing screws one after the other to the specified torque.

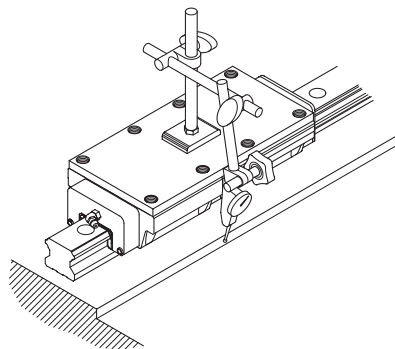

##### Align to a ruler:

Align the rail from end to end using a dial gauge on a ruler. Make sure to tighten the fixing screws firmly one after the other.

The assembly of the follow-on rail corresponds to the procedure of section 2.8.2.2, "Mounting the profile rail on the follow-on side".

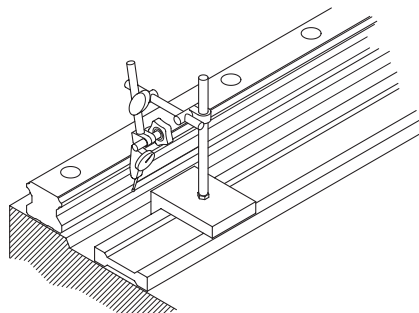

## 2.8.4 Attached profile rails

Attached (multi-part) rails must be mounted according to the applied markings. The joints on each section are marked consecutively in alphabetical order and with the rail or pair number so that each rail section can be clearly assigned.

Each joint is labelled on the top of the rail. The label serves as an aid for initial assembly and can be removed at any time without leaving any residue.

Note: After initial assembly of the profile rails, the labels must be removed.

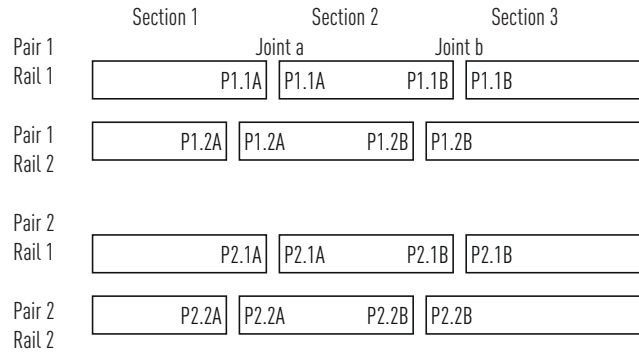
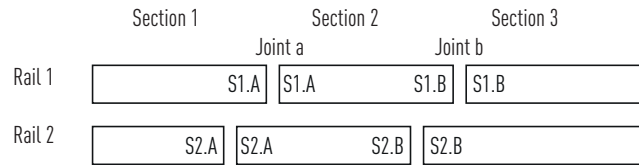

With paired multi-part rails, it is recommended that the butt joints be mounted with an offset.

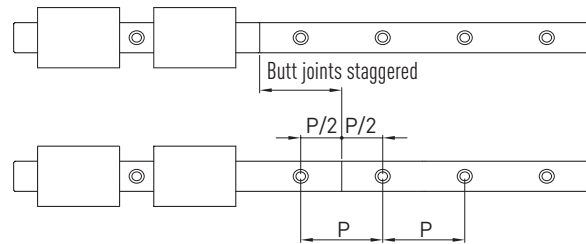

## 2.8.5 Tightening torques of the fixing screws

Insufficient tightening of the fixing screws severely affects the accuracy of the linear guideway; the tightening torques of the fastening screws according to ISO 4762-12.9 can be taken from the assembly instructions.

# Linear guideways

## General information

### 2.9 Sealing systems

On the one hand, the HIWIN end seals prevent the ingress of foreign substances such as dust particles, chips or liquid into the ball tracks of the block; on the other hand, they reduce lubricant loss. HIWIN offers various sealing systems for the different environmental conditions of your application. The effectiveness of the end seal has a direct influence on the service life of the linear guideway and should therefore be taken into account at the design stage and selected to suit the environmental conditions of your application.

Table 2.6 Overview of sealing systems

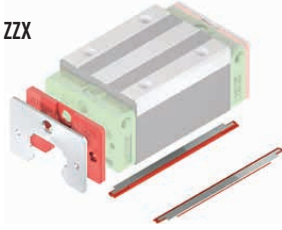
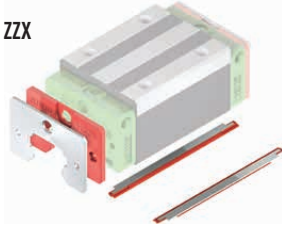
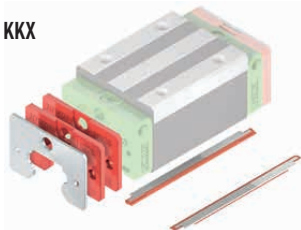
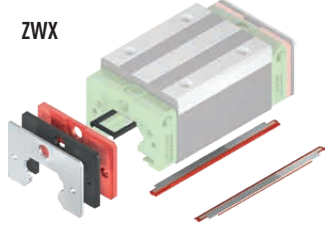
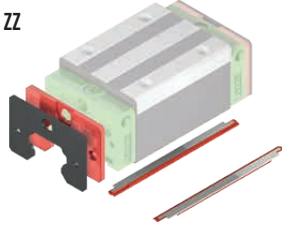
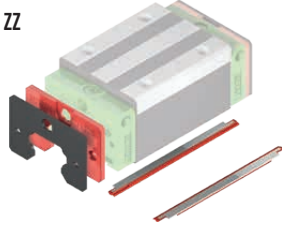
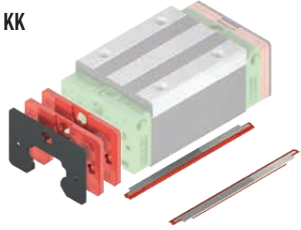
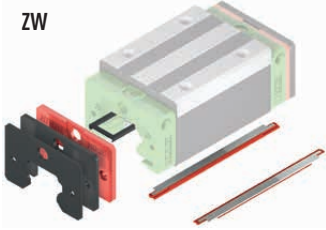
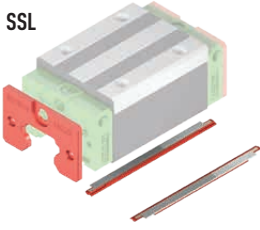
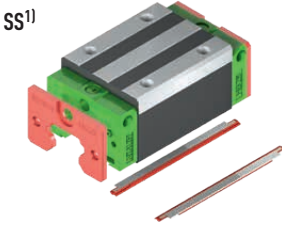
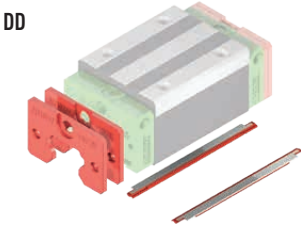
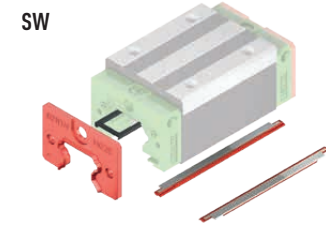
	Smooth running seal Good sealing effect, minimum displacement resistance	Standard end seal Very good sealing effect, minor displacement resistance	Double standard end seal Improved sealing effect, average displacement resistance	Optimised end seal Optimal protection against finest dusts and liquids, increased displacement resistance
Protection of the end seal from mechanical damage	<b>Scrapper</b> (Air gap 0.1 – 0.2 mm) 	<b>ZZX</b> 	<b>KKX</b> 	<b>ZWX</b> 
	<b>Scrapper</b> (Air gap 0.4 – 0.5 mm) 	<b>ZZ</b> 	<b>KK</b> 	<b>ZW</b> 
	<b>Without scrapper</b> 	<b>SS<sup>1)</sup></b> 	<b>DD</b> 	<b>SW</b> 
	<b>Sealing effect and displacement resistance higher</b>			

<sup>1)</sup> Standard

Note: The sealing systems available in each case can be found in the chapter of the series in the Sealing systems section.

Table 2.7 Selection guide for sealing systems

	<p><b>ZZX</b> See SS, additionally sharp-edged particles, possibly also hot particles or particles adhering to the rail <math>\geq 0.2</math> mm, e.g. chips, welding beads</p> <p>Typical applications:</p> <ul style="list-style-type: none"> <li>- Turning, milling, drilling</li> <li>- Welding applications</li> </ul>	<p><b>KKX</b> See DD, additionally sharp-edged particles, possibly also hot particles or particles adhering to the rail <math>\geq 0.2</math> mm, e.g. chips, welding beads</p> <p>Typical applications:</p> <ul style="list-style-type: none"> <li>- See ZWX</li> </ul>	<p><b>ZWX</b> See SW, additionally sharp-edged particles, possibly also hot particles or particles adhering to the rail <math>\geq 0.2</math> mm, e.g. chips, welding beads</p> <p>Typical applications:</p> <ul style="list-style-type: none"> <li>- CNC machining centre</li> <li>- Woodworking (e.g. MDF)</li> </ul>
	<p><b>ZZ</b> See SS, additionally sharp-edged particles, possibly also hot particles or particles adhering to the rail <math>\geq 0.4</math> mm, e.g. chips, welding beads</p> <p>Typical applications:</p> <ul style="list-style-type: none"> <li>- Turning, milling, drilling</li> <li>- Welding applications</li> </ul>	<p><b>KK</b> See DD, additionally sharp-edged particles, possibly also hot particles or particles adhering to the rail <math>\geq 0.4</math> mm, e.g. chips, welding beads</p> <p>Typical applications:</p> <ul style="list-style-type: none"> <li>- See ZW</li> </ul>	<p><b>ZW</b> See SW, additionally sharp-edged particles, possibly also hot particles or particles adhering to the rail <math>\geq 0.4</math> mm, e.g. chips, welding beads</p> <p>Typical applications:</p> <ul style="list-style-type: none"> <li>- Turning, milling, drilling (with cooling lubricants)</li> <li>- Solid wood processing with coarse chips</li> </ul>
<p><b>SSL</b> For applications with very low dirt and dust exposure</p> <p>Typical applications:</p> <ul style="list-style-type: none"> <li>- Measuring technology</li> <li>- Testing technology</li> </ul>	<p><b>SS (standard variants)</b> For applications with low dirt and dust exposure</p> <p>Typical applications:</p> <ul style="list-style-type: none"> <li>- Automation technology</li> <li>- Pick &amp; place</li> <li>- Handling</li> </ul>	<p><b>DD</b> For applications with heavy dirt and dust exposure (alternatively if SW is not available)</p> <p>Typical applications:</p> <ul style="list-style-type: none"> <li>- See SW</li> </ul>	<p><b>SW</b> For applications with heavy dirt and dust exposure, especially very fine dust and cooling lubricants</p> <p>Typical applications:</p> <ul style="list-style-type: none"> <li>- Wood, stone, glass processing</li> <li>- Grinding machines</li> </ul>

# Linear guideways

## General information

### 2.10 SynchMotion™ technology

The innovative SynchMotion™ technology reduces contact between the rolling elements and the block. Similar to the ball cage of a standard ball bearing, the rolling elements are kept at a defined distance from each other by SynchMotion™ technology. Counter-rotating friction, as occurs in conventional linear guideways, is thus prevented and synchronisation fluctuations are significantly reduced. Even at high speeds, no uncontrolled ball movements occur. SynchMotion™ technology also improves lubricant transport within the block and lubricant storage.

#### Advantages:

- Improved synchronous performance
- Optimised for high travel speeds
- Improved lubrication properties
- Reduced running noise
- Higher dynamic load rating

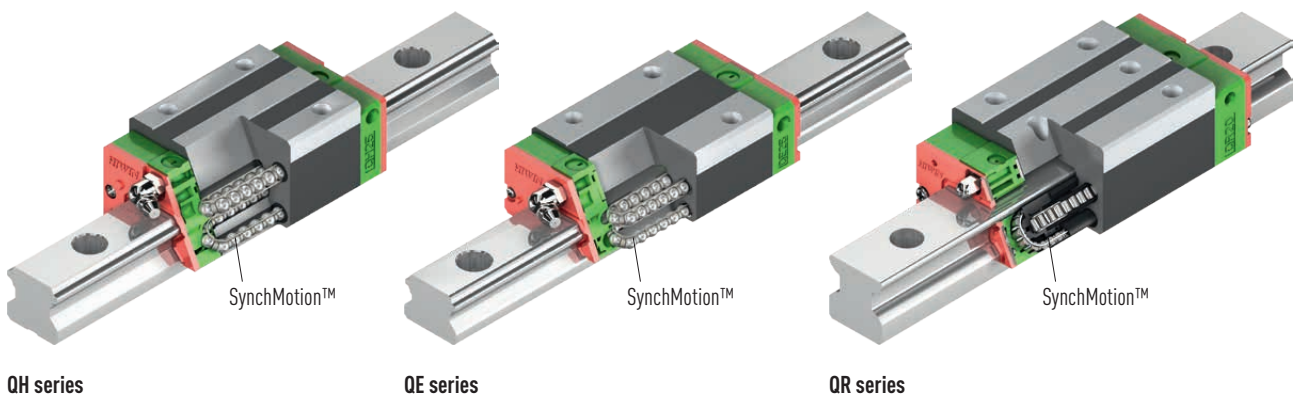

Table 2.8 Availability of SynchMotion™ technology for HIWIN linear guideways

Series	Sizes									
	15	20	21	25	27	30	35	45	55	65
QH	●	●	—	●	—	●	●	●	—	—
QE	●	●	—	●	—	●	●	—	—	—
QW	—	—	●	—	●	—	●	—	—	—
QR	—	—	—	●	—	●	●	●	—	—

Dimensionally identical and compatible with the HG, EG, WE and RG blocks, the blocks with SynchMotion™ technology are mounted on the standard rail and are therefore very easy to exchange.

## 2.11 Heat-resistant linear guideways

For continuous operation at temperatures above 80 °C, "solid steel" blocks with steel deflection systems are used. The standard end seals are replaced by heat-resistant end seals and the plastic cover caps of the profile rail by brass cover caps.

### Special properties:

- Good temperature resistance
- Operating temperature up to 150 °C
- Temperature peaks of up to 180 °C.

### Application areas:

- Devices for heat treatment
- Welding devices
- Devices for glass production
- Devices for use in a vacuum.

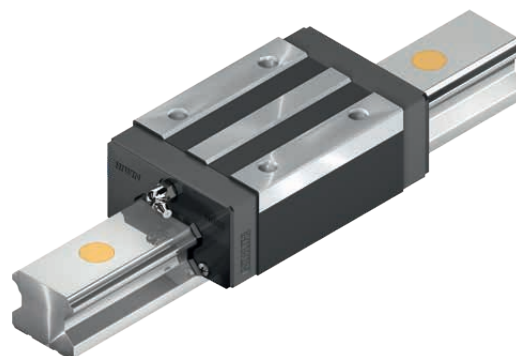

Table 2.9 Series with available steel deflection system option

Series	Size
<b>HG</b>	15, 20, 25, 30, 35, 45, 55, 65
<b>EG</b>	20, 25
<b>MGN</b>	7, 9, 12, 15
<b>MGW</b>	12, 15

**Article number:** For the steel deflection system option, add identifier "/SE" to the order code. See the structure of the order code in the chapter on the individual series.  
 HG: from Page 34, EG: from Page 70, MG: from Page 131

Order example:



Note: Heat-resistant linear guideways with steel deflector generally have poorer running properties than comparable standard linear guideways with plastic deflector and are always supplied assembled as linear guideways.

# Linear guideways

## General information

### 2.12 Corrosion-resistant linear guideways

Linear guideways are available in various materials and coatings for different requirements and applications.

#### 2.12.1 HIWIN coating HICOAT CZS

##### 2.12.1.1 Features and properties

HICOAT CZS is a very thin zinc coating that provides very good corrosion protection, even in radii and chamfers. Smaller bare spots remain protected against corrosion by the cathodic protection effect. This results in a significantly longer service life compared to uncoated parts. CZS coating available for the HG, EG, CG and WE series.  
Note: Not for series RG, MG, PG, QH, QE, QR and QW.

##### Specific features:

- Very good corrosion protection
- Cr(VI)-free
- One-piece and multi-piece rails available from stock
- End preservation with zinc spray (see below)
- Possible interaction between coating, ambient medium and lubricant should be checked on a case-by-case basis

##### Technical data:

- Salt spray test according to DIN EN ISO 9227 (with unloaded rail): 300 hours
- Salt spray test according to DIN EN ISO 9227 (with loaded rail): 99 hours
- Maximum rail length (one-piece): 4.0 meters

#### 2.12.1.2 Order code for CZS coatings

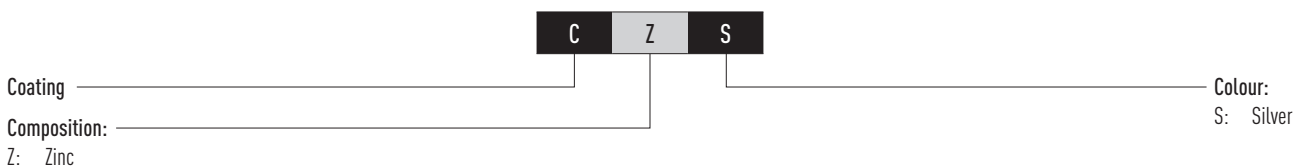

#### 2.12.1.3 Corrosion test

CZS-coated profile rails were tested in comparison with an uncoated profile rail.



New rail in CZS coating



Rail with CZS coating – after 6 months of outdoor storage



Rail (unloaded) with CZS coating – after 99 hours of salt spray test (according to DIN EN ISO 9227)



Uncoated rail – after 4 hours of salt spray test

#### 2.12.1.4 Rail end

The rail ends are preserved with zinc spray. In order to achieve reliable corrosion protection at the uncoated rail ends as well, a high-quality zinc spray (zinc content 99%) is used. The rail ends of single-piece rails and the outer ends of multi-piece rails are preserved with zinc spray approx. 2 mm beyond the cut edge as shown in Fig. 2.1. Rail ends at joints are supplied with a greased, uncoated cut edge (see Fig. 2.2).

**Note:** The mounting holes and the process-related contact points on the underside of the rail may have lower coating thicknesses or isolated bare spots. The inner side of the block is generally not coated.

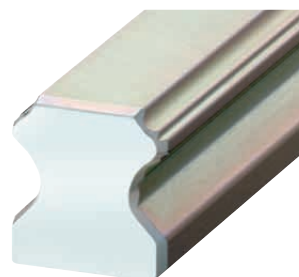

Fig. 2.1 Rail end preserved with zinc spray

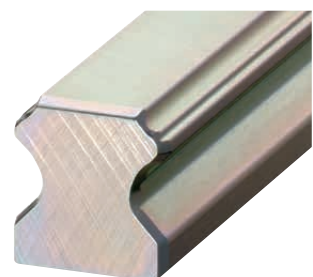

Fig. 2.2 Joint uncoated spray

## 2.12.2 HIWIN coating HICOAT CTS

### 2.12.2.1 Features and properties

HICOAT CTS is a thin film chromium plating that provides good corrosion protection and very good wear protection. The high wear resistance results from the very high hardness of the coating. The CTS coating is Cr(VI)-free and food safe. It is available for the HG, EG, CG and WE series.

#### Specific features:

- Very good wear protection
- Good corrosion protection
- Cr(VI)-free
- One-piece rails available from stock (end preservation with zinc spray, see below)
- Multi-piece rails are delivered including coated ends (longer delivery time)
- Food safe

#### Technical data:

- Salt spray test according to DIN EN ISO 9227 (with unloaded rail): 96 hours
- Salt spray test according to DIN EN ISO 9227 (with loaded rail): 22 hours
- Maximum rail length (one-piece): 4.0 meters

### 2.12.2.2 Order code for CTS coatings

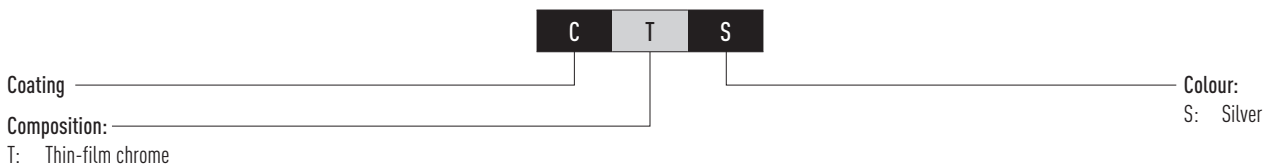

### 2.12.2.3 Corrosion test

CTS-coated profile rails were tested in comparison with an uncoated profile rail.



New rail in CTS coating



Rail with CTS coating - after 1 month of outdoor storage



Rail (unloaded) with CTS coating - after 22 hours of salt spray test (according to DIN EN ISO 9227)



Uncoated rail – after 4 hours of salt spray test

### 2.12.2.4 Rail end

For one-piece rails, the rail ends are preserved with zinc spray as shown in the adjacent figure. In order to achieve reliable corrosion protection at the uncoated rail ends as well, a high-quality, food-safe zinc spray (zinc content 99%) is used. Multi-piece rails are delivered with coated rail ends (longer delivery time).

**Note:** The mounting holes may have lower coating thicknesses or isolated bare spots. The inner side of the block is generally not coated.



# Linear guideways

## General information

---

### 2.12.3 Coating HICOAT CCB

#### 2.12.3.1 Features and properties

HICOAT CCB is a very thin chromium oxide layer with a cured synthetic resin coating. It is characterised by good corrosion protection combined with very good running properties. The very thin layer thickness enables use with all HIWIN linear guideways, especially with the MG and RG series.

#### Specific features:

- Very thin layer thickness
- Very good running properties
- Good corrosion protection
- Cr(VI)-free
- Including coated rail end
- Available from Taiwan stock

#### Technical data:

- Salt spray test according to DIN EN ISO 9227 (with unloaded rail): 24 hours
- Maximum rail length (one-piece): 4.0 meters

#### 2.12.3.2 Order code for CCB coatings

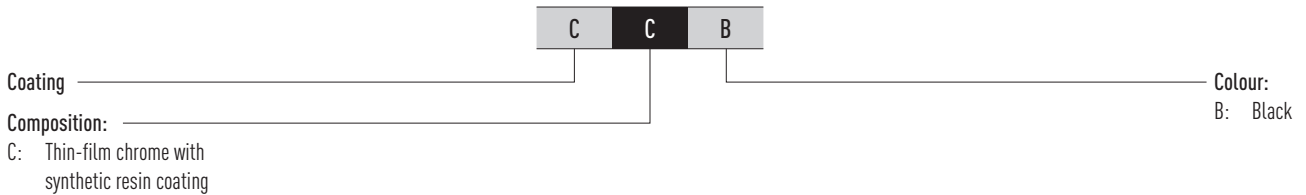

#### 2.12.3.3 Corrosion test

CCB-coated profile rails were tested in comparison with an uncoated profile rail.



New rail in CCB coating



Rail (unloaded) with CCB coating - after 24 hours of salt spray test (according to DIN EN ISO 9227)



Uncoated rail - after 4 hours of salt spray test

## 2.12.3.4 Order codes for coated linear guideways

### Order code for linear guideway (assembled)

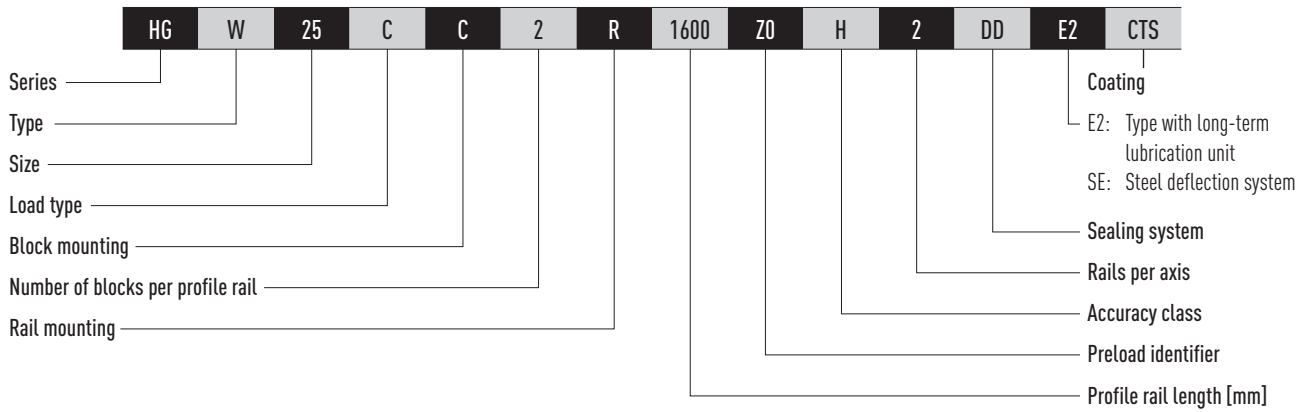

# Linear guideways

## General information

### 2.12.4 Corrosion-resistant steel HIRES

#### 2.12.4.1 Features and properties

HIRES is a corrosion-resistant steel that offers better corrosion protection than standard rolling bearing steel. The properties such as rigidity, hardness, load ratings and dimensions are the same when compared to the standard version. Details on these properties can be found in the chapter on the respective series.

The following series are available in corrosion-resistant steel: HG15, HG20, HG25 and MG02-MG15.

The components labelled in the picture are made of corrosion-resistant steel:

Fig. 2.3 Components made of corrosion-resistant steel

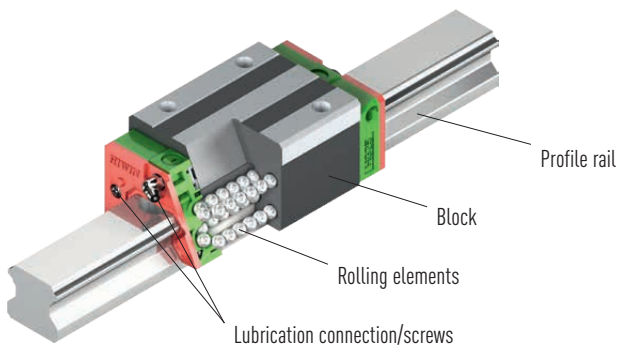

#### Specific features:

- All steel parts made of corrosion-resistant steel in accordance with DIN EN 10088
- Good corrosion protection
- Same technical properties as the standard version
- One-piece and multi-piece rails available
- Optionally with stainless steel deflector
- Various sealing systems available (SS, DD, ZZ, KXX)

#### Technical data:

- Salt spray test according to DIN EN ISO 9227 (with unloaded rail): 32 hours
- Maximum rail length (one-piece): 1.86 meters

#### Application areas:

- Food processing, food transport, food storage
- Clean room or vacuum applications
- Semiconductors
- Medical technology
- Automation
- In humid environments (water mist/water spray)
- Use of cleaning agents

#### 2.12.4.2 Order codes for HIRES corrosion-resistant steel

M

M: Corrosion-resistant steel

## 2.12.4.3 Corrosion test

Profile rails made of corrosion-resistant steel were tested in comparison to a standard profile rail.



New HIRES rail



HIRES rail (unloaded) after 32 hours salt spray test (according to DIN EN ISO 9227)



Standard rail - after 4 hours salt spray test

## 2.12.4.4 Order code Profile rail guide made of corrosion-resistant steel (assembled)

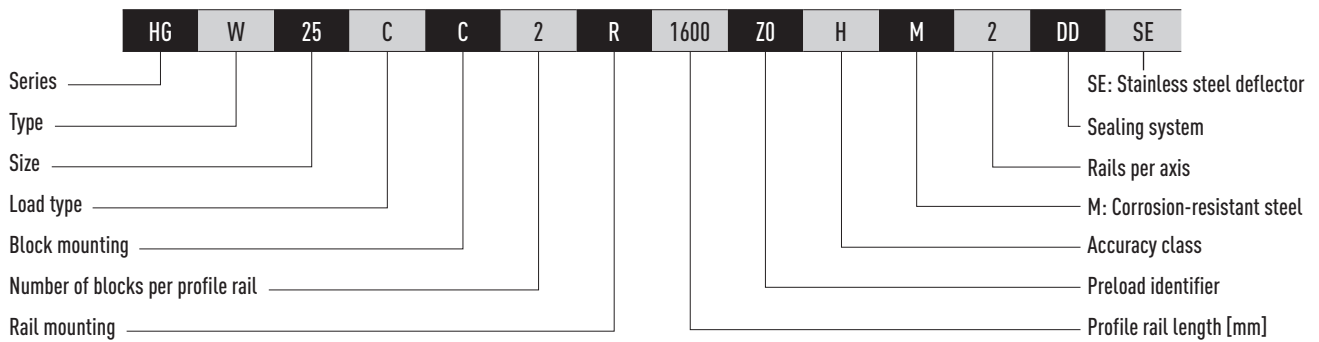

# Linear guideways

Linear guideways: Series

## 3. Linear guideways: Series

### 3.1 HG/QH series

#### 3.1.1 Properties of the HG and QH series linear guideways

Standard series in X arrangement. The HIWIN linear guideways of the HG series with four ball tracks are designed for high loads and rigidities. Due to the 45° arrangement of the ball tracks, the HG series can take loads from all directions equally.

Low displacement forces and high efficiency are additional features of the HG series. The ball retainers prevent the balls from falling out when pulled from the profile rail during installation of the blocks.

The models of the QH series with SynchMotion™ technology offer all the advantages of the standard HG series. Controlled movement of the balls at a defined distance also results in improved synchronous performance, higher reliable travel speeds, extended lubrication intervals and less running noise. Since the installation dimensions of the QH blocks are identical to those of the HG blocks, they are also mounted on the HGR standard rail and can thus be easily interchanged. For further information, see Page 26. Sizes 15, 20 and 25 are also available in corrosion-resistant steel.

#### 3.1.2 Layout of HG/QH series

- Four-row recirculating ball bearing guide
- 45° contact angle of the ball tracks
- The ball retainers prevent the balls from falling out when the block is removed
- Different sealing variants, depending on application area
- 6 connection options for lubricating nipples
- SynchMotion™ technology (QH series)
- Size 15, 20, 25 also available in corrosion-resistant steel

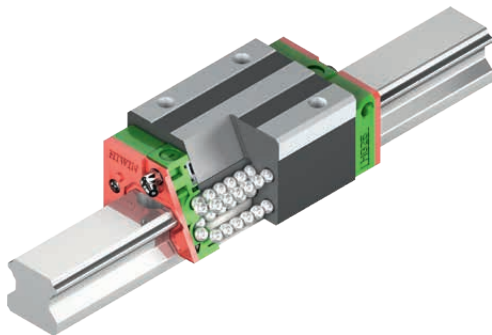

Layout of HG series

#### Advantages:

- Backlash-free
- Exchangeable
- High accuracy
- Highly resilient in all loading directions
- Low friction losses even with preload from optimised ball tracks and 2-point contact

#### 3.1.3 Order codes of HG/QH series

For HG/QH linear guideways, there is a distinction made between assembled and non-assembled models. The dimensions of both models are the same. The main difference is that, in the unassembled models, blocks and profile rails can be freely interchanged. Block and profile rail can be ordered separately and mounted by the customer. Their accuracy reaches class P.

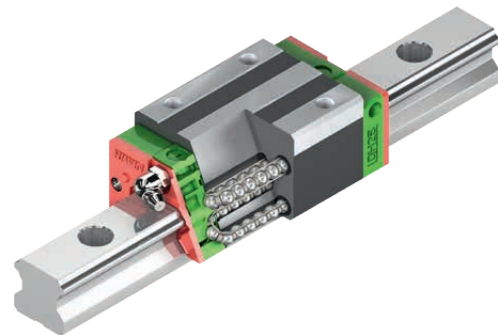

Layout of QH series

#### Additional advantages of QH series:

- Improved synchronous performance
- Optimised for higher travel speeds
- Extended relubrication intervals
- Reduced running noise
- Higher dynamic load rating

## Order code for linear guideway (assembled)

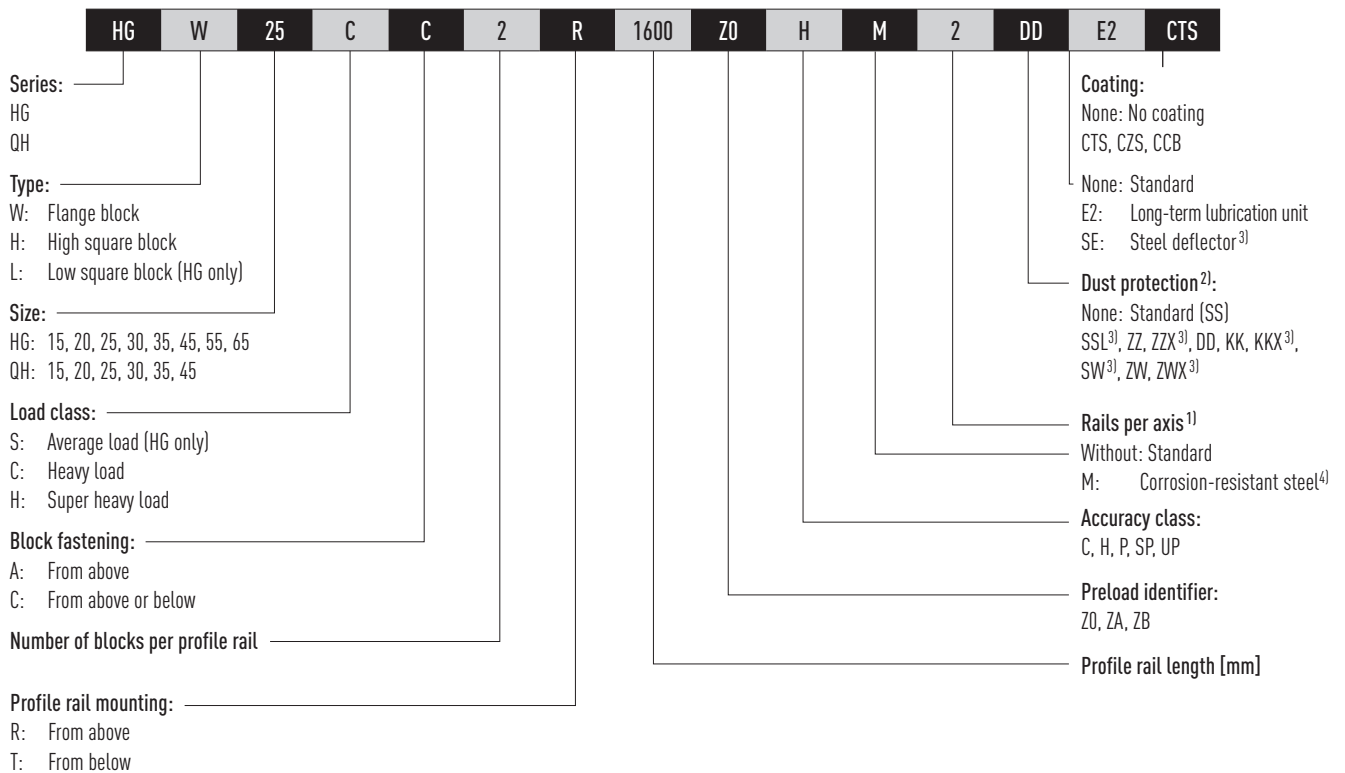

## Order code Carriage (not mounted)

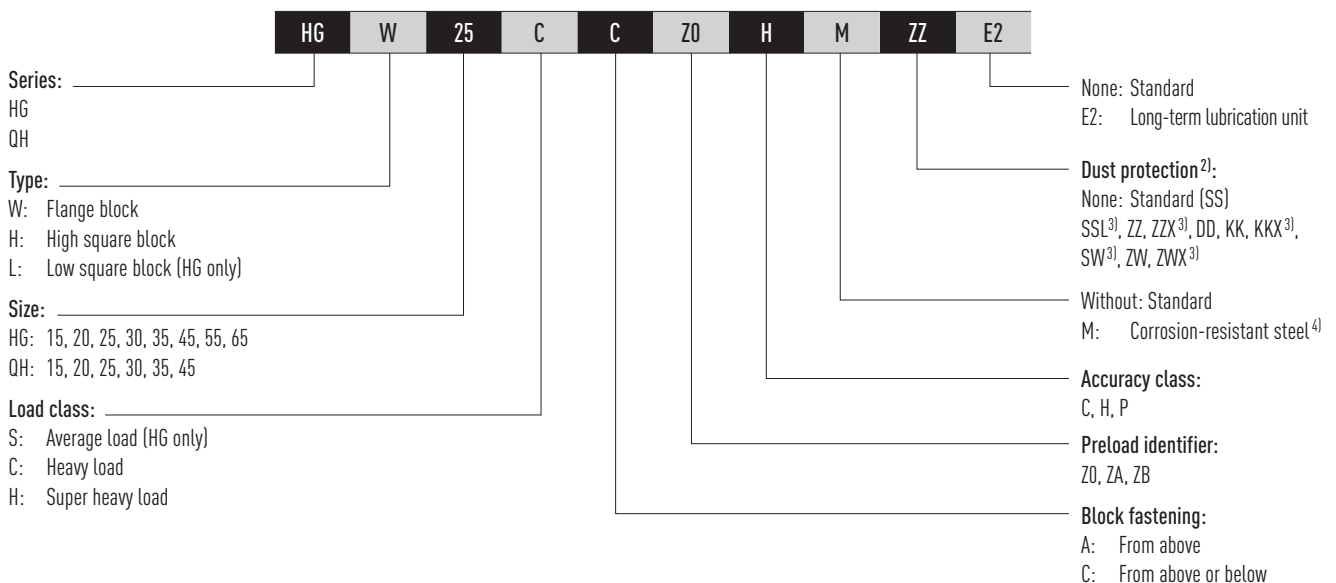

### Note:

<sup>1)</sup> The number 2 is also a quantity indication, i.e. one piece of the article described above consists of one pair of rails.  
 No number is given for single profile rails. In the case of multi-part rails, the joint is offset as standard.

<sup>2)</sup> An overview of the individual sealing systems can be found on Page 24

<sup>3)</sup> Not available for QH

<sup>4)</sup> Corrosion-resistant steel available in: HG series, H and W type, size 15-25, load type C, preload Z0 and ZA, accuracy class H. More information in chapter 2.12.4

# Linear guideways

HG/QH series

## Order number of profile rail (not assembled)

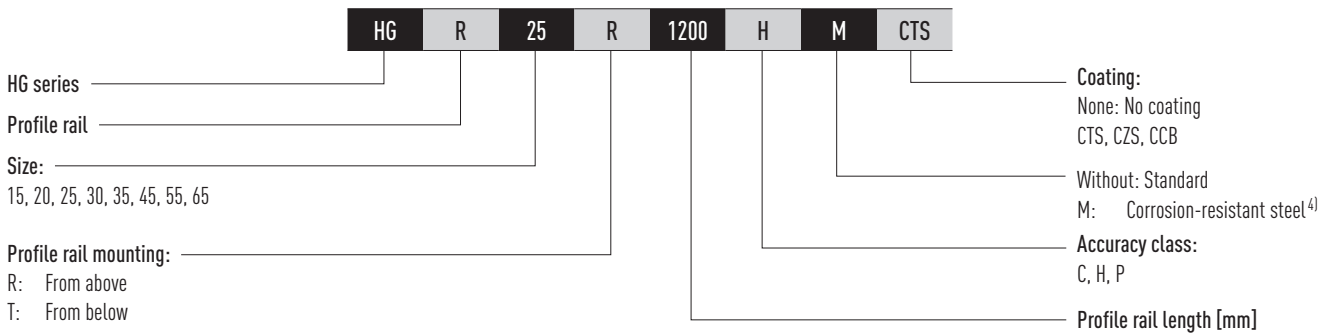

Note:

<sup>4)</sup> Corrosion-resistant steel available in: HG series, H and W type, size 15-25, load type C, preload Z0 and ZA, accuracy class H. More information in chapter 2.12.4

### 3.1.4 Block types

HIWIN offers block and flange blocks for its linear guideways. Due to the low installation height and the larger mounting surface, flange blocks are better suited for large loads.

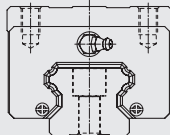
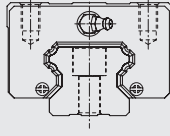
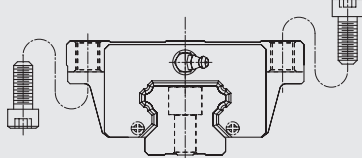
Table 3.1 Block types				
Type	Series/size	Layout	Height [mm]	Typical applications
<b>High square type</b>	HGH-CA HGH-HA		28 - 90	<ul style="list-style-type: none"> <li>- Machining centres</li> <li>- NC lathes</li> <li>- Grinding machines</li> <li>- Precision milling machines</li> <li>- High performance cutting machines</li> <li>- Automation technology</li> <li>- Transport technology</li> <li>- Measuring technology</li> <li>- Machines and devices with high required positioning accuracy</li> </ul>
<b>Low square type</b>	HGL-CA HGL-HA		24 - 70	
<b>Flange type</b>	HGW-CC HGW-HC		24 - 90	

<sup>1)</sup> Optional type on request

### 3.1.5 Profile rail types

In addition to profile rails with standard fastening from above, HIWIN also offers rails for fastening from below.

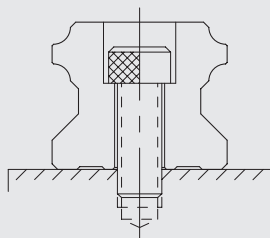
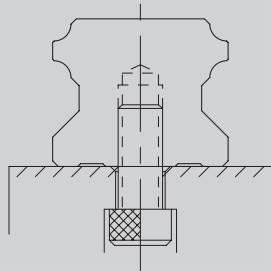
Table 3.2 Profile rail types	
Fastening from above	Fastening from below
	
HGR_R	HGR_T

## 3.1.6 Preload

### Definition

Each linear guideway can be preloaded via the ball size. The curve shows that the rigidity doubles at high preload. The HG/QH series of linear guideways offers three standard preloads for different applications and conditions.

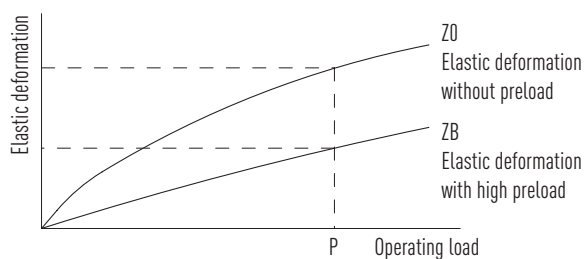

### Preload identifier

Table 3.3 Preload identifier				
Identifier	Preload		Application	Example applications
Z0	Slight preload	$0 - 0.02 C_{dyn}$	Constant load direction, little vibration, less accuracy required	<ul style="list-style-type: none"> <li>- Transport technology</li> <li>- Automatic packaging machines</li> <li>- X-Y axis in industrial machines</li> <li>- Welding machines</li> </ul>
ZA	Medium preload	$0.05 - 0.07 C_{dyn}$	High accuracy required	<ul style="list-style-type: none"> <li>- Machining centres</li> <li>- Z axes in industrial machines</li> <li>- Eroding machines</li> <li>- NC lathes</li> <li>- Precision X-Y table</li> <li>- Measuring technology</li> </ul>
ZB	High preload	Over $0.1 C_{dyn}$	High rigidity required, vibration and jolting	<ul style="list-style-type: none"> <li>- Machining centres</li> <li>- Grinding machines</li> <li>- NC lathes</li> <li>- Horizontal and vertical milling machines</li> <li>- Z-axis of machine tools</li> <li>- High performance cutting machines</li> </ul>

# Linear guideways

## HG/QH series

### 3.1.7 Load ratings and torques

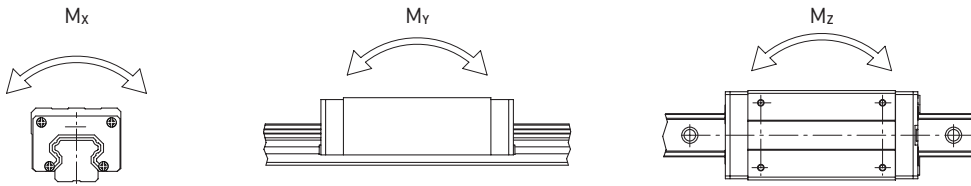

Table 3.4 Load ratings and torques for series HG/QH

Series/Size	Dynamic load rating $C_{dyn}$ [N] <sup>1)</sup>	Static load rating $C_0$ [N]	Static moment [Nm]		
			$M_{0x}$	$M_{0y}$	$M_{0z}$
HG_15C	14,700	23,470	120	140	140
QH_15C	17,940	19,860	100	112	112
HG_20S	16,840	22,570	130	80	80
HG_20C	27,100	36,680	270	280	280
QH_20C	30,000	33,860	260	266	266
HG_20H	32,700	47,960	350	480	480
QH_20H	35,700	42,310	310	370	370
HG_25S	26,930	36,560	310	160	160
HG_25C	34,900	52,820	420	490	490
QH_25C	41,900	48,750	390	460	460
HG_25H	42,200	69,070	560	730	730
QH_25H	50,610	60,940	500	576	576
HG_30C	48,500	71,870	660	700	700
QH_30C	58,260	66,340	600	660	660
HG_30H	58,600	93,990	880	1,230	1,230
QH_30H	70,320	88,450	830	1,190	1,190
HG_35C	64,600	93,990	1,160	1,090	1,090
QH_35C	78,890	86,660	1,070	1,022	1,022
HG_35H	77,900	122,770	1,540	2,020	2,020
QH_35H	95,230	115,550	1,450	1,919	1,919
HG_45C	103,800	146,710	1,980	2,350	2,350
QH_45C	119,400	135,420	1,830	2,092	2,092
HG_45H	125,300	191,850	2,630	4,450	4,450
QH_45H	144,130	180,560	2,470	4,002	4,002
HG_55C	153,200	211,230	3,690	3,684	3,684
HG_55H	184,900	276,230	4,880	6,650	6,650
HG_65C	213,200	287,480	6,650	5,870	5,870
HG_65H	277,800	420,170	9,380	12,574	12,574

<sup>1)</sup> Dynamic load rating for 50,000 m travel path

### 3.1.8 Rigidity

The rigidity depends on the preload. With the formula F 3.1, the deformation can be calculated depending on the rigidity.

F 3.1

$$\delta = \frac{P}{k}$$

$\delta$  Deformation [ $\mu\text{m}$ ]  
 P Operating load [N]  
 k Rigidity value [N/ $\mu\text{m}$ ]

Table 3.5 Radial rigidity of HG/QH series				
Load type	Series/ Size	Rigidity depending on the preload		
		Z0	ZA	ZB
Average load	HG_20S	124	210	270
	HG_25S	195	320	360
Heavy load	HG_15C	196	365	483
	QH_15C	174	292	384
	HG_20C	232	460	678
	QH_20C	221	396	542
	HG_25C	292	539	705
	QH_25C	254	419	548
	HG_30C	354	618	823
	QH_30C	326	526	716
	HG_35C	395	642	865
	QH_35C	375	566	762
	HG_45C	505	738	980
	QH_45C	480	644	850
	HG_55C	609	828	1,092
	HG_65C	716	918	1,201
Super heavy load	HG_20H	300	611	824
	QH_20H	294	534	735
	HG_25H	378	715	935
	QH_25H	332	567	739
	HG_30H	453	820	1,093
	QH_30H	420	699	945
	HG_35H	509	855	1,150
	QH_35H	487	757	1,010
	HG_45H	649	970	1,298
	QH_45H	620	853	1,128
	HG_55H	789	1,085	1,445
	HG_65H	946	1,221	1,599

Unit: N/ $\mu\text{m}$

# Linear guideways

## HG/QH series

### 3.1.9 Dimensions of the HG/QH blocks

#### 3.1.9.1 HGH/QHH

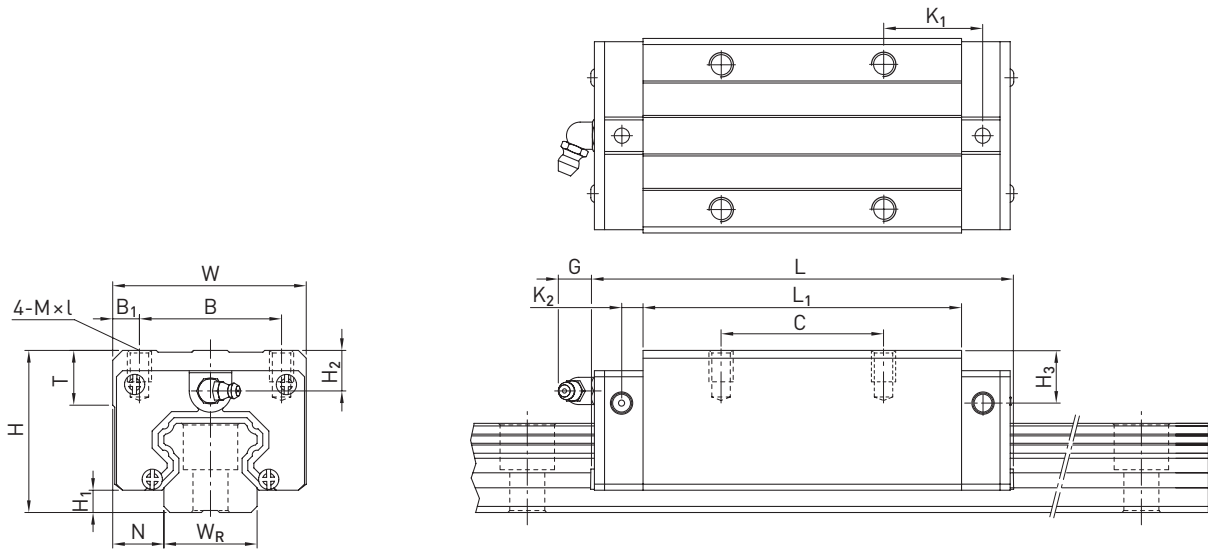

Table 3.6 Dimensions of the block

Series/size	Installation dimensions [mm]			Dimensions of the block [mm]													Load ratings [N]		Weight [kg]
	H	H <sub>1</sub>	N	W	B	B <sub>1</sub>	C	L <sub>1</sub>	L	K <sub>1</sub>	K <sub>2</sub>	G	M × l	T	H <sub>2</sub>	H <sub>3</sub>	C <sub>dyn</sub>	C <sub>0</sub>	
HGH15CA	28	4.3	9.5	34	26	4.0	26	39.4	61.4	10.00	4.85	5.3	M4 × 5	6.0	7.95	7.7	14,700	23,470	0.18
QHH15CA	28	4.0	9.5	34	26	4.0	26	39.4	61.4	10.00	5.00	5.3	M4 × 5	6.0	7.95	8.2	17,940	19,860	0.18
HGH20CA	30	4.6	12.0	44	32	6.0	36	50.5	77.5	12.25	6.00	12.0	M5 × 6	8.0	6.00	6.0	27,100	36,680	0.30
HGH20HA							50	65.2	92.2	12.60							32,700	47,960	0.39
QHH20CA	30	4.6	12.0	44	32	6.0	36	50.5	76.7	11.75	6.00	12.0	M5 × 6	8.0	6.00	6.0	30,000	33,860	0.29
QHH20HA							50	65.2	91.4	12.10							35,700	42,310	0.38
HGH25CA	40	5.5	12.5	48	35	6.5	35	58.0	84.0	15.70	6.00	12.0	M6 × 8	8.0	10.00	9.0	34,900	52,820	0.51
HGH25HA							50	78.6	104.6	18.50							42,200	69,070	0.69
QHH25CA	40	5.5	12.5	48	35	6.5	35	58.0	83.4	15.70	6.00	12.0	M6 × 8	8.0	10.00	9.0	41,900	48,750	0.50
QHH25HA							50	78.6	104.0	18.50							50,610	60,940	0.68
HGH30CA	45	6.0	16.0	60	40	10.0	40	70.0	97.4 <sup>1)</sup>	20.25	6.00	12.0	M8 × 10	8.5	9.50	13.8	48,500	71,870	0.88
HGH30HA							60	93.0	120.4 <sup>2)</sup>	21.75							58,600	93,990	1.16
QHH30CA	45	6.0	16.0	60	40	10.0	40	70.0	97.4	19.50	6.25	12.0	M8 × 10	8.5	9.50	9.0	58,260	66,340	0.87
QHH30HA							60	93.0	120.4	21.75							70,320	88,450	1.15
HGH35CA	55	7.5	18.0	70	50	10.0	50	80.0	112.4	20.60	7.00	12.0	M8 × 12	10.2	16.00	19.6	64,600	93,990	1.45
HGH35HA							72	105.8	138.2	22.50							77,900	122,770	1.92
QHH35CA	55	7.5	18.0	70	50	10.0	50	80.0	113.6	19.00	7.50	12.0	M8 × 12	10.2	15.50	13.5	78,890	86,660	1.44
QHH35HA							72	105.8	139.4	20.90							95,230	115,550	1.90
HGH45CA	70	9.5	20.5	86	60	13.0	60	97.0	139.4	23.00	10.00	12.9	M10 × 17	16.0	18.50	30.5	103,800	146,710	2.73
HGH45HA							80	128.8	171.2	28.90							125,300	191,850	3.61
QHH45CA	70	9.2	20.5	86	60	13.0	60	97.0	139.4	23.00	10.00	12.9	M10 × 17	16.0	18.50	20.0	119,400	135,420	2.72
QHH45HA							80	128.8	171.2	29.09							144,130	180,560	3.59
HGH55CA	80	13.0	23.5	100	75	12.5	75	117.7	166.7	27.35	11.00	12.9	M12 × 18	17.5	22.00	29.0	153,200	211,230	4.17
HGH55HA							95	155.8	204.8	36.40							184,900	276,230	5.49
HGH65CA	90	15.0	31.5	126	76	25.0	70	144.2	200.2	43.10	14.00	12.9	M16 × 20	25.0	15.00	15.0	213,200	287,480	7.00
HGH65HA							120	203.6	259.6	47.80							277,800	420,170	9.82

<sup>1)</sup> 98.8 for type SE

<sup>2)</sup> 121.8 for type SE

For dimensions of the rail, see Page 43, for standard as well as optional lubrication adapter, see Page 152.

## 3.1.9.2 HGL

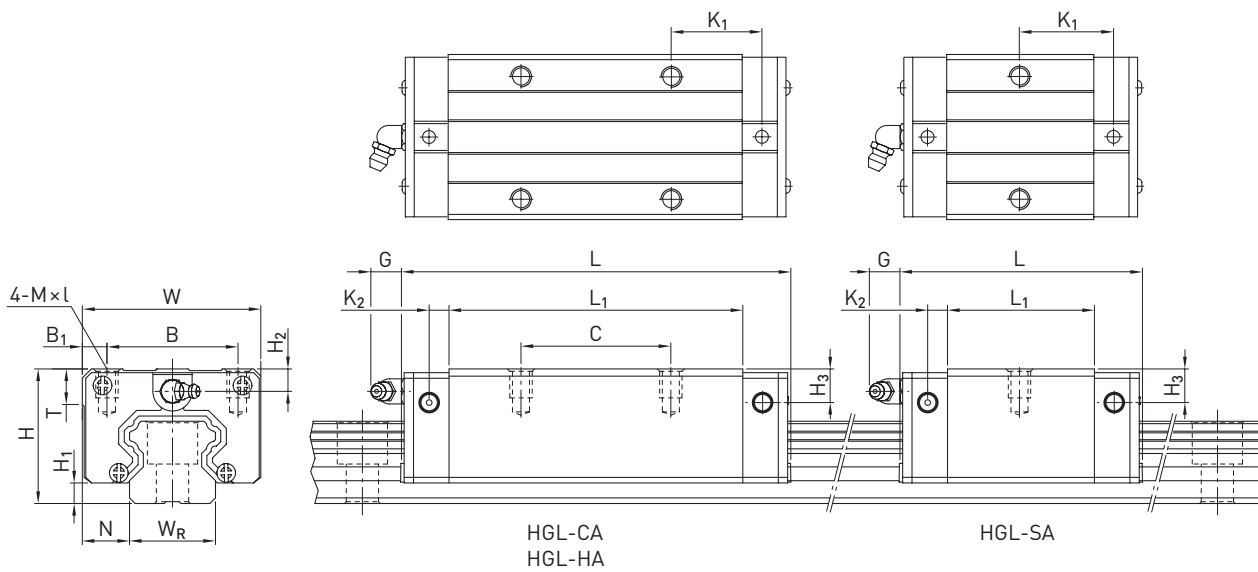

Table 3.7 Dimensions of the block

Series/size	Installation dimensions [mm]			Dimensions of the block [mm]													Load ratings [N]		Weight [kg]
	H	H <sub>1</sub>	N	W	B	B <sub>1</sub>	C	L <sub>1</sub>	L	K <sub>1</sub>	K <sub>2</sub>	G	M × l	T	H <sub>2</sub>	H <sub>3</sub>	C <sub>dyn</sub>	C <sub>0</sub>	
HGL15CA	24	4.3	9.5	34	26	4.0	26	39.4	61.4	10.00	4.85	5.3	M4 × 4	6.0	3.95	3.7	14,700	23,470	0.14
HGL25SA	36	5.5	12.5	48	35	6.5	—	38.2	64.2	23.20	6.00	12.0	M6 × 6	8.0	6.00	5.0	26,930	36,560	0.32
HGL25CA							35	58.0	84.0	15.70							34,900	52,820	0.42
HGL25HA							50	78.6	104.6	18.50							42,200	69,070	0.57
HGL30CA	42	6.0	16.0	60	40	10.0	40	70.0	97.4 <sup>1)</sup>	20.25	6.00	12.0	M8 × 10	8.5	6.50	10.8	48,500	71,870	0.78
HGL30HA							60	93.0	120.4 <sup>2)</sup>	21.75							58,600	93,990	1.03
HGL35CA	48	7.5	18.0	70	50	10.0	50	80.0	112.4	20.60	7.00	12.0	M8 × 12	10.2	9.00	12.6	64,600	93,990	1.14
HGL35HA							72	105.8	138.2	22.50							77,900	122,770	1.52
HGL45CA	60	9.5	20.5	86	60	13.0	60	97.0	139.4	23.00	10.00	12.9	M10 × 17	16.0	8.50	20.5	103,800	146,710	2.08
HGL45HA							80	128.8	171.2	28.90							125,300	191,850	2.75
HGL55CA	70	13.0	23.5	100	75	12.5	75	117.7	166.7	27.35	11.00	12.9	M12 × 18	17.5	12.00	19.0	153,200	211,230	3.25
HGL55HA							95	155.8	204.8	36.40							184,900	276,230	4.27

<sup>1)</sup> 98.8 for type SE

<sup>2)</sup> 121.8 for type SE

For dimensions of the rail, see Page 43, for standard as well as optional lubrication adapter, see Page 152.

# Linear guideways

HG/QH series

## 3.1.9.3 HGW/QHW

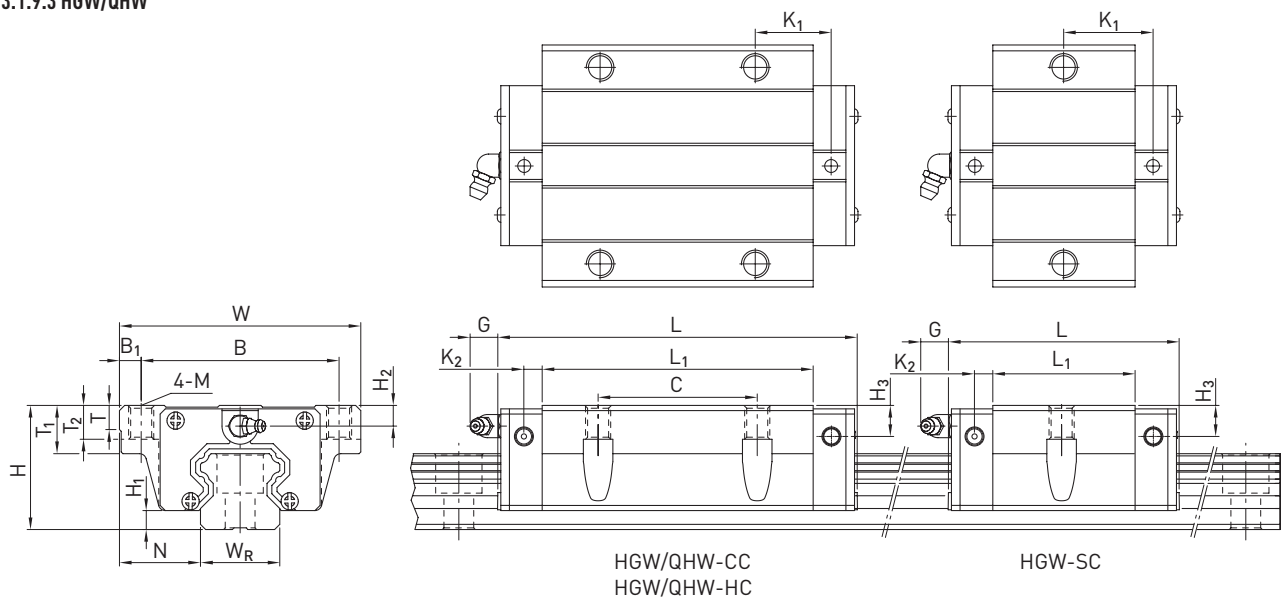

Table 3.8 Dimensions of the block

Series/size	Installation dimensions [mm]			Dimensions of the block [mm]															Load ratings [N]		Weight [kg]
	H	H <sub>1</sub>	N	W	B	B <sub>1</sub>	C	L <sub>1</sub>	L	K <sub>1</sub>	K <sub>2</sub>	M	G	T	T <sub>1</sub>	T <sub>2</sub>	H <sub>2</sub>	H <sub>3</sub>	C <sub>dyn</sub>	C <sub>0</sub>	
HGW15CC	24	4.3	16.0	47	38	4.5	30	39.4	61.4	8.00	4.85	M5	5.3	6.0	8.9	7.0	3.95	3.7	14,700	23,470	0.17
QHW15CC	24	4.0	16.0	47	38	4.5	30	39.4	61.4	8.00	5.00	M5	5.3	6.0	8.9	7.0	3.95	4.2	17,940	19,860	0.17
HGW20SC	30	4.6	21.5	63	53	5.0	—	29.5	54.3	19.65	6.00	M6	12.0	8.0	10.0	9.5	6.00	6.0	16,840	22,570	0.28
HGW20CC							40	50.5	77.5	10.25									27,100	36,680	0.40
HGW20HC							65.2	92.2	17.60	32,700									47,960	0.52	
QHW20CC	30	4.6	21.5	63	53	5.0	40	50.5	76.7	9.75	6.00	M6	12.0	8.0	10.0	9.5	6.00	6.0	30,000	33,860	0.40
QHW20HC							65.2	91.4	17.10	35,700									42,310	0.52	
HGW25SC	36	5.5	23.5	70	57	6.5	—	38.2	64.2	23.20	6.00	M8	12.0	8.0	14.0	10.0	6.00	5.0	26,930	36,560	0.42
HGW25CC							45	58.0	84.0	10.70									34,900	52,820	0.59
HGW25HC							78.6	104.6	21.00	42,200									69,070	0.80	
QHW25CC	36	5.5	23.5	70	57	6.5	45	58.0	83.4	10.70	6.00	M8	12.0	8.0	14.0	10.0	6.00	5.0	41,900	48,750	0.59
QHW25HC							78.6	104.0	21.00	50,610									60,940	0.80	
HGW30CC	42	6.0	31.0	90	72	9.0	52	70.0	97.4 <sup>1)</sup>	14.25	6.00	M10	12.0	8.5	16.0	10.0	6.50	10.8	48,500	71,870	1.09
HGW30HC							93.0	120.4 <sup>2)</sup>	25.75	58,600									93,990	1.44	
QHW30CC	42	6.0	31.0	90	72	9.0	52	70.0	97.4	13.50	6.25	M10	12.0	8.5	16.0	10.0	6.50	6.0	58,260	66,340	1.09
QHW30HC							93.0	120.4	25.75	70,320									88,450	1.44	
HGW35CC	48	7.5	33.0	100	82	9.0	62	80.0	112.4	14.60	7.00	M10	12.0	10.1	18.0	13.0	9.00	12.6	64,600	93,990	1.56
HGW35HC							105.8	138.2	27.50	77,900									122,770	2.06	
QHW35CC	48	7.5	33.0	100	82	9.0	62	80.0	113.6	13.00	7.50	M10	12.0	10.1	18.0	13.0	8.50	6.5	78,890	86,660	1.56
QHW35HC							105.8	139.4	25.90	95,230									115,550	2.06	
HGW45CC	60	9.5	37.5	120	100	10.0	80	97.0	139.4	13.00	10.00	M12	12.9	15.1	22.0	15.0	8.50	20.5	103,800	146,710	2.79
HGW45HC							128.8	171.2	28.90	125,300									191,850	3.69	
QHW45CC	60	9.2	37.5	120	100	10.0	80	97.0	139.4	13.00	10.00	M12	12.9	15.1	22.0	15.0	8.50	10.0	119,400	135,420	2.79
QHW45HC							128.8	171.2	28.90	144,130									180,560	3.69	
HGW55CC	70	13.0	43.5	140	116	12.0	95	117.7	166.7	17.35	11.00	M14	12.9	17.5	26.5	17.0	12.00	19.0	153,200	211,230	4.52
HGW55HC							155.8	204.8	36.40	184,900									276,230	5.96	
HGW65CC	90	15.0	53.5	170	142	14.0	110	144.2	200.2	23.10	14.00	M16	12.9	25.0	37.5	23.0	15.00	15.0	213,200	287,480	9.17
HGW65HC							203.6	259.6	52.80	277,800									420,170	12.89	

<sup>1)</sup> 98.8 for type SE; <sup>2)</sup> 121.8 for type SE

For dimensions of the rail, see Page 43, for standard as well as optional lubrication adapter see Page 152.

### 3.1.10 Dimensions of the HG rail

The HG profile rail is used for both the HG and QH blocks.

#### 3.1.10.1 Dimensions HGR\_R

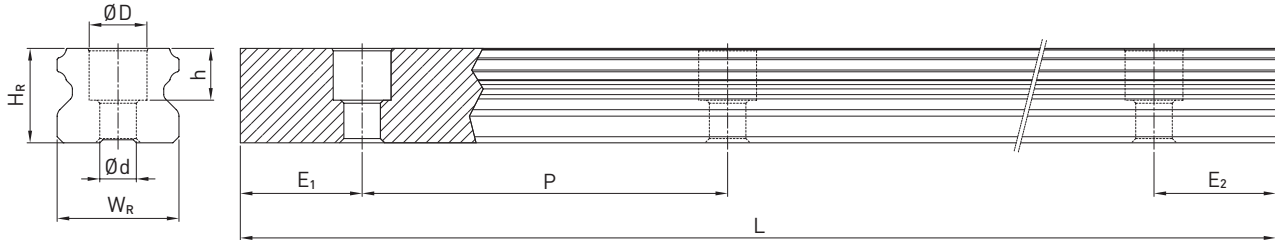

Table 3.9 Dimensions of profile rail HGR\_R

Series/size	Assembly screw for rail [mm]	Dimensions of the rail [mm]						Max. length [mm] <sup>2)</sup>	Max. length E <sub>1</sub> = E <sub>2</sub> [mm]	Min. length [mm]	E <sub>1/2</sub> min [mm]	E <sub>1/2</sub> max [mm]	Weight [kg/m]
		W <sub>R</sub>	H <sub>R</sub>	D	h	d	P						
HGR15R	M4 × 20	15	15.0	7.5	5.3	4.5	60	4,000	3,900	72	6	54	1.45
HGR20R	M5 × 20	20	17.5	9.5	8.5	6.0	60	4,000/5,600 <sup>1)</sup>	3,900/5,520 <sup>1)</sup>	74	7	53	2.21
HGR25R	M6 × 25	23	22.0	11.0	9.0	7.0	60	4,000/5,600 <sup>1)</sup>	3,900/5,520 <sup>1)</sup>	76	8	52	3.21
HGR30R	M8 × 30	28	26.0	14.0	12.0	9.0	80	4,000/5,600 <sup>1)</sup>	3,920/5,520 <sup>1)</sup>	98	9	71	4.47
HGR35R	M8 × 35	34	29.0	14.0	12.0	9.0	80	4,000/5,600 <sup>1)</sup>	3,920/5,520 <sup>1)</sup>	98	9	71	6.30
HGR45R	M12 × 45	45	38.0	20.0	17.0	14.0	105	4,000/5,600 <sup>1)</sup>	3,885/5,460 <sup>1)</sup>	129	12	93	10.41
HGR55R	M14 × 55	53	44.0	23.0	20.0	16.0	120	4,000/5,600 <sup>1)</sup>	3,840/5,440 <sup>1)</sup>	148	14	106	15.08
HGR65R	M16 × 65	63	53.0	26.0	22.0	18.0	150	4,000/5,600 <sup>1)</sup>	3,750/5,350 <sup>1)</sup>	180	15	135	21.18

<sup>1)</sup> Optional type on request

<sup>2)</sup> Max. length of corrosion-resistant steel: 1,860mm

#### 3.1.10.2 Dimensions HGR\_T

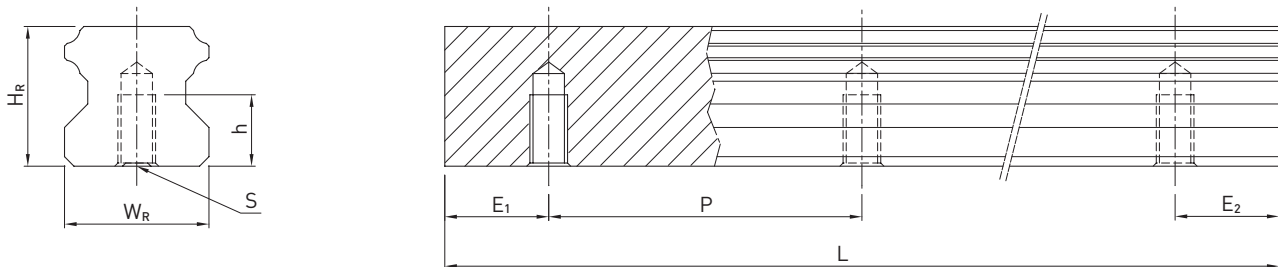

Table 3.10 Dimensions of profile rail HGR\_T

Series/size	Dimensions of the rail [mm]					Max. length [mm] <sup>2)</sup>	Max. length E <sub>1</sub> = E <sub>2</sub> [mm]	Min. length [mm]	E <sub>1/2</sub> min [mm]	E <sub>1/2</sub> max [mm]	Weight [kg/m]
	W <sub>R</sub>	H <sub>R</sub>	S	h	P						
HGR15T	15	15.0	M5	8	60	4,000	3,900	72	6	54	1.48
HGR20T	20	17.5	M6	10	60	4,000	3,900	74	7	53	2.29
HGR25T	23	22.0	M6	12	60	4,000	3,900	76	8	52	3.35
HGR30T	28	26.0	M8	15	80	4,000	3,920	98	9	71	4.67
HGR35T	34	29.0	M8	17	80	4,000	3,920	98	9	71	6.51
HGR45T	45	38.0	M12	24	105	4,000	3,885	129	12	93	10.87
HGR55T	53	44.0	M14	24	120	4,000	3,840	148	14	106	15.67
HGR65T	63	53.0	M20 <sup>1)</sup>	30	150	4,000	3,750	180	15	135	21.73

<sup>1)</sup> Deviates from DIN 645

<sup>2)</sup> Max. length of corrosion-resistant steel: 1,860mm

Note:

- The tolerance for E is +0.5 to -1 mm for standard, for joint connections 0 to -0.3 mm.
- If no information is provided on the E<sub>1/2</sub> dimensions, the maximum number of mounting holes is determined taking into account E<sub>1/2</sub> min.
- The rails are shortened to the desired length. If no information on the E<sub>1/2</sub> dimensions is provided, then the rails are manufactured symmetrically.

# Linear guideways

## HG/QH series

### 3.1.10.3 Calculation of the length of profile rails

HIWIN offers profile rails in customised lengths. To make sure the end of the profile rail does not become unstable, the value E should not exceed half the distance between the mounting holes (P). At the same time, the value  $E_{1/2}$  should be between  $E_{1/2 \text{ min}}$  and  $E_{1/2 \text{ max}}$  so that the mounting hole does not break out.

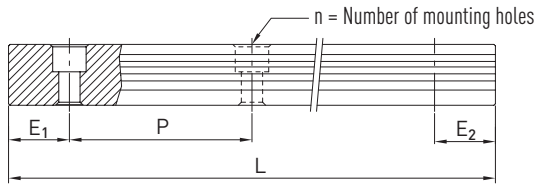

F 3.2

$$L = (n - 1) \times P + E_1 + E_2$$

- L Total length of the profile rail [mm]
- n Number of mounting holes
- P Distance between two mounting holes [mm]
- $E_{1/2}$  Distance from the centre of the last mounting hole to the end of the profile rail [mm].

### 3.1.10.4 Cover caps for mounting holes of profile rails

The cover caps are used to keep the mounting holes free of chips and dirt. The standard plastic cover caps accompany each profile rail. Optional cover caps have to be ordered separately.



Table 3.11 Cover caps for mounting holes of profile rails

Rail	Screw	Article number			Ø D [mm]	Height H [mm]
		Plastic (200 units)	Brass <sup>1)</sup>	Steel <sup>1)</sup>		
HGR15R	M4	5-002218	5-001344	—	7.5	1.2
HGR20R	M5	5-002220	5-001350	5-001352	9.5	2.5
HGR25R	M6	5-002221	5-001355	5-001357	11.0	2.8
HGR30R	M8	5-002222	5-001360	5-001362	14.0	3.5
HGR35R	M8	5-002222	5-001360	5-001362	14.0	3.5
HGR45R	M12	5-002223	5-001324	5-001327	20.0	4.0
HGR55R	M14	5-002224	5-001330	5-001332	23.0	4.0
HGR65R	M16	5-002225	5-001335	5-001337	26.0	4.0

<sup>1)</sup> Not recommended for coated rails.

### 3.1.11 Sealing systems

Different sealing systems are available for HIWIN blocks. You can find an overview on Page 24. The following table shows the total length of the blocks with different sealing systems. Appropriate sealing systems are available for these sizes.

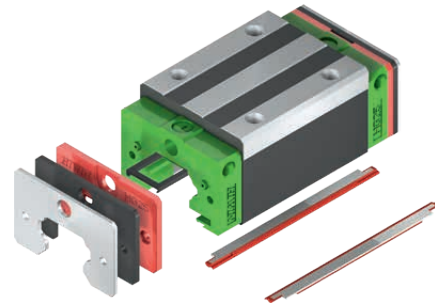

Table 3.12 Total length of block with different sealing systems

Series/size	Total length L (including screws)									
	SS	SSL	ZZ	ZZX	DD	KK	KKX	SW	ZW	ZWX
HG_15C	61.4	61.4	69.0	69.0	68.0	75.6	75.6	63.2	71.0	71.0
QH_15C	61.4	—	68.4	—	68.0	75.0	—	—	—	—
HG_20S	56.5	56.5	57.5	57.5	59.5	62.5	62.5	57.5	—	61.3
HG_20C	77.5	77.5	82.5	82.5	82.5	87.5	87.5	78.5	86.3	82.3
QH_20C	76.7	—	81.9	—	81.7	86.9	—	—	—	—
HG_20H	92.2	92.2	97.2	97.2	97.5	102.2	102.2	93.2	101.0	97.0
QH_20H	91.4	—	96.6	—	96.4	101.6	—	—	—	—
HG_25C	84.0	84.0	89.0	92.0	89.0	94.0	97.0	85.0	92.8	91.8
QH_25C	83.4	—	89.4	—	88.4	94.4	—	—	—	—
HG_25H	104.6	104.6	109.6	112.6	109.6	114.6	114.6	105.6	113.4	112.4
QH_25H	104.4	—	110.0	—	109.0	115.0	—	—	—	—
HG_30C	97.4	97.4	105.4	108.4	104.8	112.8	115.8	99.0	107.2	105.8
QH_30C	97.4	—	104.8	—	104.8	112.2	—	—	—	—
HG_30H	120.4	120.4	128.4	131.4	127.8	135.8	138.8	122.0	130.2	128.8
QH_30H	120.4	—	127.8	—	127.8	135.2	—	—	—	—
HG_35C	112.4	—	120.4	123.4	119.8	127.8	130.8	115.2	123.4	122.4
QH_35C	113.6	—	119.0	—	118.6	124.0	—	—	—	—
HG_35H	138.2	—	146.2	149.2	145.6	153.6	156.6	141.0	149.2	148.2
QH_35H	139.4	—	144.8	—	144.4	149.8	—	—	—	—
HG_45C	139.4	—	150.0	153.0	149.4	160.0	160.0	140.0	148.8	144.8
QH_45C	139.4	—	147.2	—	146.6	154.4	—	—	—	—
HG_45H	171.2	—	181.8	184.8	181.2	191.8	194.8	171.8	180.6	176.6
QH_45H	171.2	—	179.0	—	178.4	186.2	—	—	—	—
HG_55C	166.7	—	177.1	180.1	177.1	187.5	190.5	163.7	—	172.9
HG_55H	204.8	—	215.2	218.2	215.2	225.5	228.5	201.8	—	211.0
HG_65C	200.2	—	208.2	211.2	209.2	217.2	220.2	196.2	—	203.4
HG_65H	259.6	—	267.6	270.6	268.6	276.6	258.6	255.6	—	262.8

Unit: mm

# Linear guideways

## HG/QH series

---

### 3.1.11.1 Designation of the seal sets

The seal sets are always shipped complete with the installation materials and include the supplemental parts for the standard seal.

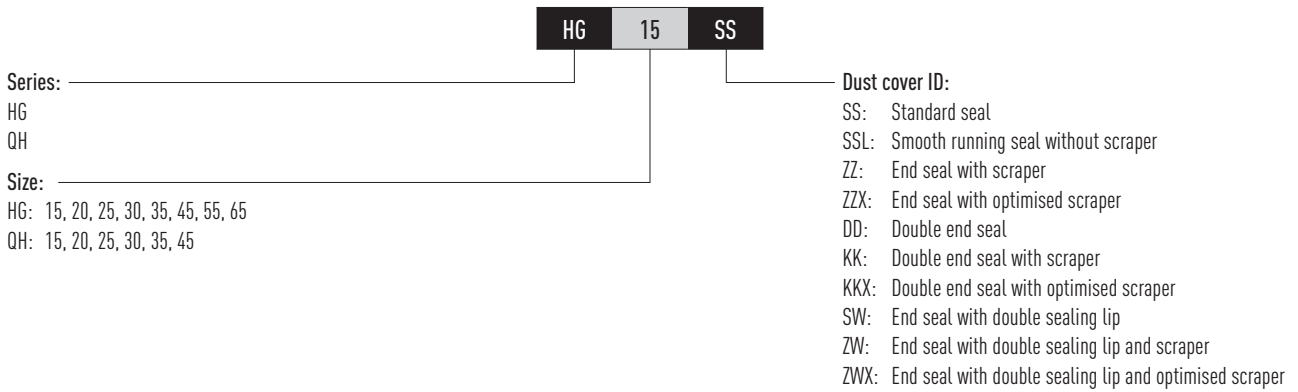

### 3.1.12 Long-term lubrication unit

Further information on the lubrication unit can be found in the general information

In section "2.6.3 Long-term lubrication unit" on Page 17.

The following drawing shows the dimension (L) for a single-sided lubrication unit (standard). The dimension for a double-sided lubrication unit results from the dimension  $L + V + T$ . The E2 long-term lubrication unit is available with the sealing systems named in the table.

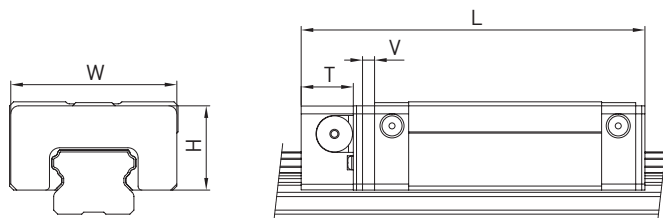

Table 3.13 Dimensions of the block with lubrication unit E2

Model	Dimensions of the block [mm]								Max running performance <sup>2)</sup> [km] E2 single-sided	Max running performance <sup>2)</sup> [km] E2 double-sided
	W	H	T	V	L <sub>SS</sub> <sup>1)</sup>	L <sub>ZZ</sub> <sup>1)</sup>	L <sub>DD</sub> <sup>1)</sup>	L <sub>KK</sub> <sup>1)</sup>		
HG_15C	32.4	19.5	12.5	3.0	75.4	80.5	82.0	87.1	10,000	20,000
QH_15C	32.4	19.5	12.5	3	75.4	-	-	-	20,000	30,000
HG_20S	43.0	24.4	13.5	3.5	70.9	73.0	75.0	78.0	10,000	20,000
HG_20C	43.0	24.4	13.5	3.5	93.5	95.6	97.5	100.6	10,000	20,000
QH_20C	43	24.4	13.5	3.5	93.1	-	-	-	20,000	30,000
HG_20H	43.0	24.4	13.5	3.5	108.2	110.2	112.2	115.2	10,000	20,000
QH_20H	43	24.4	13.5	3.5	107.8	-	-	-	20,000	30,000
HG_25C	46.4	29.5	13.5	3.5	100.0	102.0	104.0	107.0	10,000	20,000
QH_25C	46.4	29.5	13.5	3.5	100.2	-	-	-	20,000	30,000
HG_25H	46.4	29.5	13.5	3.5	120.6	122.6	124.6	127.6	10,000	20,000
QH_25H	46.4	29.5	13.5	3.5	120.8	-	-	-	20,000	30,000
HG_30C	58.0	35.0	13.5	3.5	112.9	118.0	119.9	125.0	10,000	20,000
QH_30C	58	35	13.5	3.5	112.9	-	-	-	20,000	30,000
HG_30H	58.0	35.0	13.5	3.5	135.9	141.0	142.9	148.0	10,000	20,000
QH_30H	58	35	13.5	3.5	135.9	-	-	-	20,000	30,000
HG_35C	68.0	38.5	13.5	3.5	127.9	133.4	135.3	140.8	10,000	20,000
QH_35C	68	35.5	16	3.5	129.3	-	-	-	20,000	30,000
HG_35H	68.0	38.5	13.5	3.5	153.7	159.2	161.1	166.6	10,000	20,000
QH_35H	68	35.5	16	3.5	155.1	-	-	-	20,000	30,000
HG_45C	82.0	49.0	16.0	4.5	157.2	162.1	166.1	171.7	10,000	20,000
QH_45C	82	49	16	4.5	158.3	-	-	-	20,000	30,000
HG_45H	82.0	49.0	16.0	4.5	189.0	193.9	197.9	203.5	10,000	20,000
QH_45H	82	49	16	4.5	190.1	-	-	-	20,000	30,000
HG_55C	97.0	55.5	16.0	4.5	183.9	189.6	193.8	200.0	10,000	20,000
HG_55H	97.0	55.5	16.0	4.5	222.0	227.7	231.9	238.1	10,000	20,000
HG_65C	121.0	69.0	16.0	4.5	219.2	220.7	226.7	229.7	10,000	20,000
HG_65H	121.0	69.0	16.0	4.5	278.6	280.1	286.1	289.1	10,000	20,000

<sup>1)</sup> Total length depending on the selected dust protection. SS = Standard dust protection

<sup>2)</sup> Further details can be found in the assembly instructions in the "Lubrication" chapter

# Linear guideways

## HG/QH series

### 3.1.13 Tolerances depending on the accuracy class

The HG and QH series are available in five accuracy classes according to the parallelism between block and rail, height accuracy H and width accuracy N. The selection of the accuracy class is determined by the requirements of the machine.

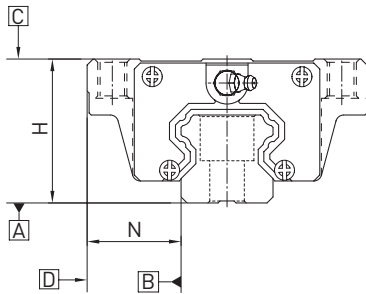

#### 3.1.13.1 Parallelism

Parallelism of locating surfaces D and B of the block and rail and of top block surface C to mounting surface A of the rail. Ideal installation of the linear guideway and the measurement in the centre of the block are prerequisites.

Table 3.14 Tolerance of parallelism between block and profile rail

Rail length [mm]	Accuracy class				
	C	H	P	SP	UP
- 100	12	7	3	2	2
100 - 200	14	9	4	2	2
200 - 300	15	10	5	3	2
300 - 500	17	12	6	3	2
500 - 700	20	13	7	4	2
700 - 900	22	15	8	5	3
900 - 1100	24	16	9	6	3
1100 - 1500	26	18	11	7	4
1500 - 1900	28	20	13	8	4
1900 - 2500	31	22	15	10	5
2500 - 3100	33	25	18	11	6
3100 - 3600	36	27	20	14	7
3600 - 4000	37	28	21	15	7

Unit:  $\mu\text{m}$

### 3.1.13.2 Accuracy – height and width

#### Height tolerance of H

Permissible absolute dimension deviation of height H, measured between the centre of bolting surface C and rail underside A, with any position of the block on the rail.

#### Height variance of H

Permissible deviation of height H between several blocks on one rail, measured at the same position of the rail.

#### Width tolerance of N

Permissible absolute dimension deviation of width N, measured between the centre of bolting surfaces D and B, with any position of the block on the rail.

#### Width variance of N

Permissible deviation of width N between several blocks on one rail, measured at the same position of the rail.

Table 3.15 Tolerances of width and height

Series/size	Accuracy class	Height tolerance of H	Width tolerance of N	Height variance of H	Width variance of N
<b>HG_15, 20</b> <b>QH_15, 20</b>	C (Normal)	± 0.1	± 0.1	0.02	0.02
	H (high)	± 0.03	± 0.03	0.01	0.01
	P (precision)	0/- 0.03 <sup>1)</sup> ± 0.015 <sup>2)</sup>	0/- 0.03 <sup>1)</sup> ± 0.015 <sup>2)</sup>	0.006	0.006
	SP (super precision)	0/- 0.015	0/- 0.015	0.004	0.004
	UP (ultra precision)	0/- 0.008	0/- 0.008	0.003	0.003
<b>HG_25, 30, 35</b> <b>QH_25, 30, 35</b>	C (Normal)	± 0.1	± 0.1	0.02	0.03
	H (high)	± 0.04	± 0.04	0.015	0.015
	P (precision)	0/- 0.04 <sup>1)</sup> ± 0.02 <sup>2)</sup>	0/- 0.04 <sup>1)</sup> ± 0.02 <sup>2)</sup>	0.007	0.007
	SP (super precision)	0/- 0.02	0/- 0.02	0.005	0.005
	UP (ultra precision)	0/- 0.01	0/- 0.01	0.003	0.003
<b>HG_45, 55</b> <b>QH_45</b>	C (Normal)	± 0.1	± 0.1	0.03	0.03
	H (high)	± 0.05	± 0.05	0.015	0.02
	P (precision)	0/- 0.05 <sup>1)</sup> ± 0.025 <sup>2)</sup>	0/- 0.05 <sup>1)</sup> ± 0.025 <sup>2)</sup>	0.007	0.01
	SP (super precision)	0/- 0.03	0/- 0.03	0.005	0.007
	UP (ultra precision)	0/- 0.02	0/- 0.02	0.003	0.005
<b>HG_65</b>	C (Normal)	± 0.1	± 0.1	0.03	0.03
	H (high)	± 0.07	± 0.07	0.02	0.025
	P (precision)	0/- 0.07 <sup>1)</sup> ± 0.035 <sup>2)</sup>	0/- 0.07 <sup>1)</sup> ± 0.035 <sup>2)</sup>	0.01	0.015
	SP (super precision)	0/- 0.05	0/- 0.05	0.007	0.01
	UP (ultra precision)	0/- 0.03	0/- 0.03	0.005	0.007

Unit: mm

<sup>1)</sup> Assembled linear guideway

<sup>2)</sup> Unassembled linear guideway

# Linear guideways

## HG/QH series

### 3.1.13.3 Permissible tolerances of the mounting surface

Once the requirements for the accuracy of the mounting surfaces are met, the high accuracy, rigidity and service life of the HG and QH series linear guideways are achieved.

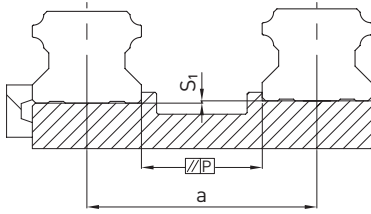

#### Tolerance of parallelism of reference surface (P):

Table 3.16 Maximum tolerance for parallelism (P)

Series/Size	Preload class		
	Z0	ZA	ZB
HG/QH_15	25	18	—
HG/QH_20	25	20	18
HG/QH_25	30	22	20
HG/QH_30	40	30	27
HG/QH_35	50	35	30
HG/QH_45	60	40	35
HG_55	70	50	45
HG_65	80	60	55

Unit:  $\mu\text{m}$

#### Tolerance of height of reference surface ( $S_1$ ):

$$F 3.3 \quad S_1 = a \times K$$

$S_1$  Maximum height tolerance [mm]  
 $a$  Distance between rails [mm]  
 $K$  Coefficient of height tolerance

Table 3.17 Coefficient of height tolerance (K)

Series/Size	Preload class		
	Z0	ZA	ZB
HG/QH_15	$2.6 \times 10^{-4}$	$1.7 \times 10^{-4}$	—
HG/QH_20	$2.6 \times 10^{-4}$	$1.7 \times 10^{-4}$	$1.0 \times 10^{-4}$
HG/QH_25	$2.6 \times 10^{-4}$	$1.7 \times 10^{-4}$	$1.4 \times 10^{-4}$
HG/QH_30	$3.4 \times 10^{-4}$	$2.2 \times 10^{-4}$	$1.8 \times 10^{-4}$
HG/QH_35	$4.2 \times 10^{-4}$	$3.0 \times 10^{-4}$	$2.4 \times 10^{-4}$
HG/QH_45	$5.0 \times 10^{-4}$	$3.4 \times 10^{-4}$	$2.8 \times 10^{-4}$
HG_55	$6.0 \times 10^{-4}$	$4.2 \times 10^{-4}$	$3.4 \times 10^{-4}$
HG_65	$7.0 \times 10^{-4}$	$5.0 \times 10^{-4}$	$4.0 \times 10^{-4}$

**3.1.14 Shoulder heights and edge roundings**

Inaccurate shoulder heights and edge roundings of mounting surfaces impair accuracy and may conflict with the block or rail profile. The following shoulder heights and edge profiles must be observed to avoid assembly problems.

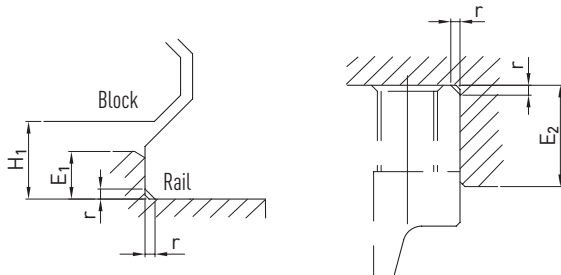

Table 3.18 Shoulder heights and edge roundings

Series/Size	Max. radius of edges $r$	Shoulder height of the reference edge of rail $E_1$	Shoulder height of the reference edge of block $E_2$	Clearance height under block $H_1$
HG_15	0.5	3.0	4.0	4.3
QH_15	0.5	3.0	4.0	4.0
HG/QH_20	0.5	3.5	5.0	4.6
HG/QH_25	1.0	5.0	5.0	5.5
HG/QH_30	1.0	5.0	5.0	6.0
HG/QH_35	1.0	6.0	6.0	7.5
HG/QH_45	1.0	8.0	8.0	9.5
HG_55	1.5	10.0	10.0	13.0
HG_65	1.5	10.0	10.0	15.0

Unit: mm

# Linear guideways

## CG series

### 3.2 CG series

#### 3.2.1 Properties of the CG series linear guideway

Standard series in O arrangement. The HIWIN linear guideways of the CG series with O-arrangement of the ball tracks guarantee high torque capacity, especially in the  $M_x$  direction. The modified track geometry ensures high load ratings. The new flexible end seal automatically adapts to the rail contour and ensures strong, durable dust protection. To protect against mechanical damage to the end seal, the blocks of the CG series are already equipped with a scraper in front of the end seal in the standard version.

A cover strip is available as an option – dirt ingress and wear of the sealing lip are thus permanently reduced to a minimum. Thanks to the mounting aid, the cover strip can be installed in just a few steps.

For optimum lubricant distribution, the block has an additional channel that introduces the lubricant into the centre of the load-bearing zone. This ensures long relubrication intervals and offers a clear advantage, especially in short-stroke applications.

#### 3.2.2 Layout of CG series

Backlash-free, four-row recirculating ball bearing guide with optimum dust protection even in the standard version.

Easy installation, better protection against dirt ingress and wear of the end seals with cover strip.

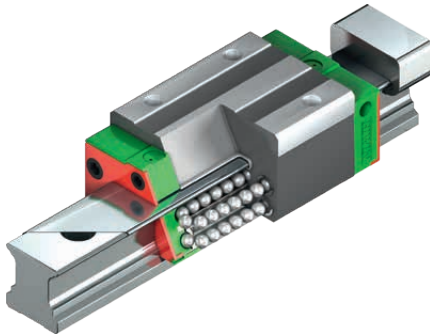

Optimised lubrication concept for long relubrication intervals and short-stroke applications.

O-arrangement with changed track geometry for high torque load and in  $M_x$  direction.

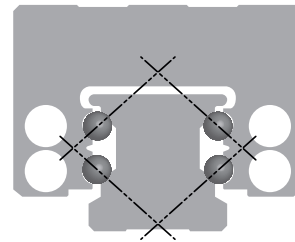
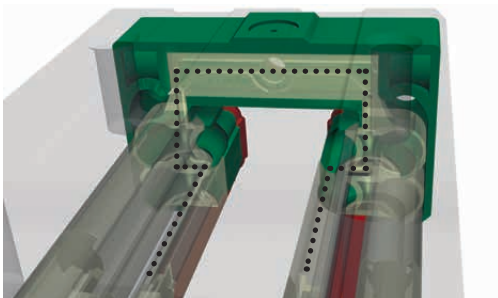

#### Advantages:

- Backlash-free
- Exchangeable
- High accuracy
- High torque capacity, special roll torque  $M_x$
- Optionally with cover strip

#### 3.2.3 Order codes of CG series

For CG linear guideways, there is a distinction made between assembled and non-assembled models. The dimensions of both models are the same. The main difference is that, in the unassembled models, blocks and profile rails can be freely interchanged. Block and profile rail can be ordered separately and mounted by the customer. Their accuracy reaches class P.

## Order code for linear guideway (assembled)

**CG W 25 C C 2 R 1600 Z0 H 2 SW EC CSS CTS**

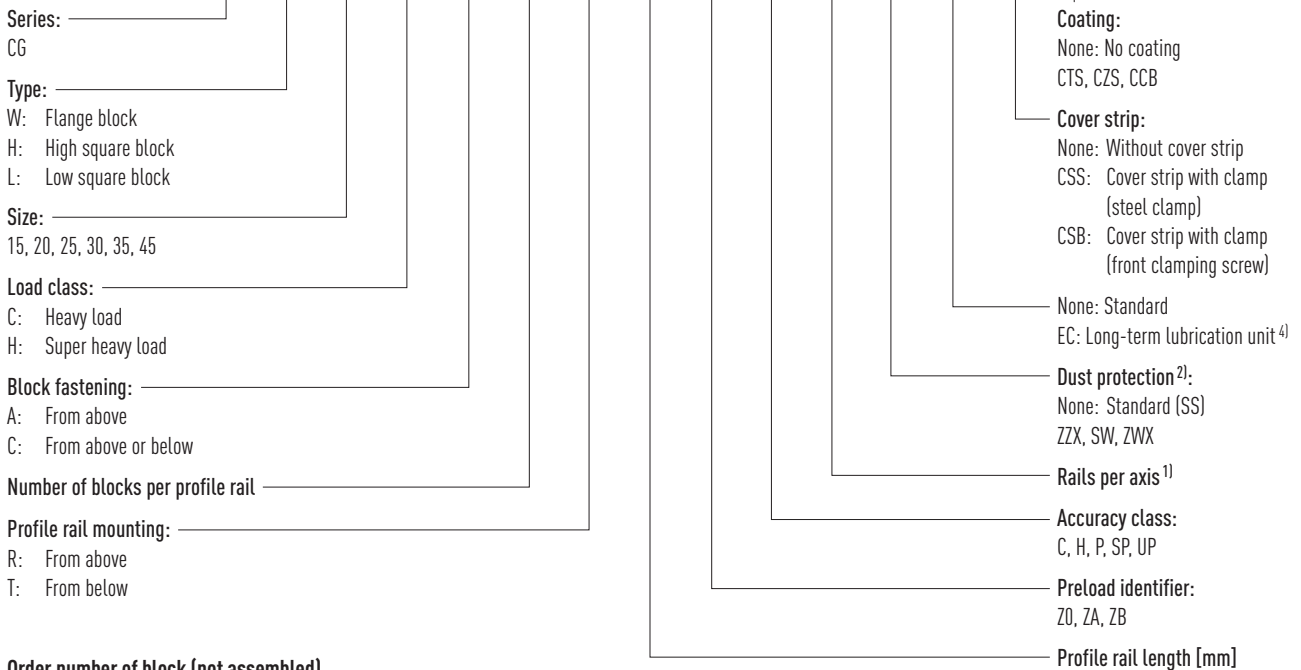

## Order number of block (not assembled)

**CG W 25 C C Z0 H SW CS**

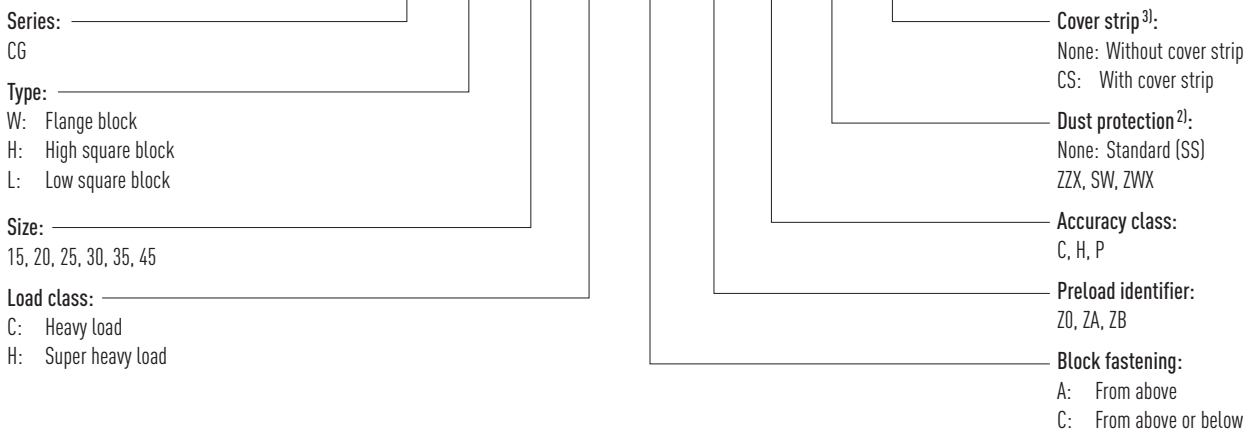

## Order number of profile rail (not assembled)

**CG R 25 R 1200 H CSS CTS**

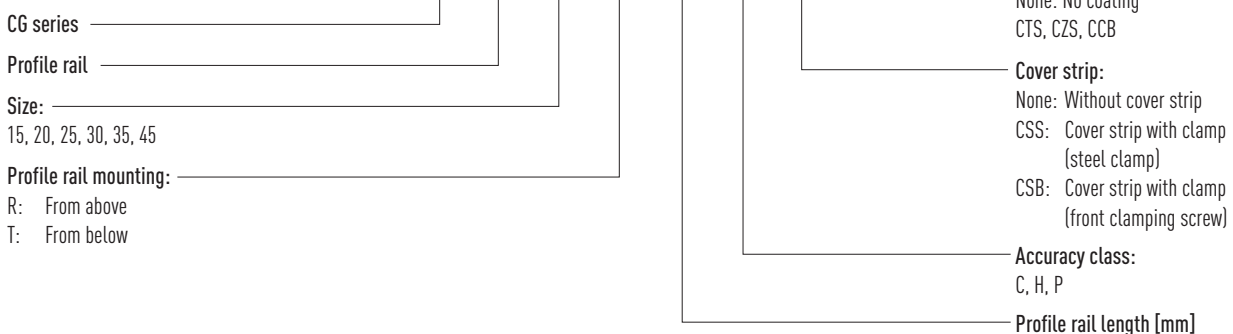

### Note:

<sup>1)</sup> The number 2 is also a quantity indication, i.e. one piece of the article described above consists of one pair of rails.

No number is given for single profile rails. In the case of multi-part rails, the joint is offset as standard.

<sup>2)</sup> An overview of the individual sealing systems can be found on Page 24

<sup>3)</sup> The standard dust protection (SS) can be used for profile rails with and without cover strip.

<sup>4)</sup> Only available for sizes 15, 20 and 25.

# Linear guideways

## CG series

### 3.2.4 Block types

HIWIN offers block and flange blocks for its linear guideways. Due to the low installation height and the larger mounting surface, flange blocks are better suited for large loads.

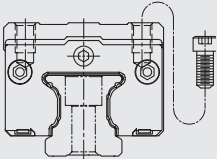
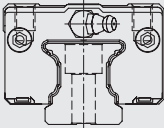
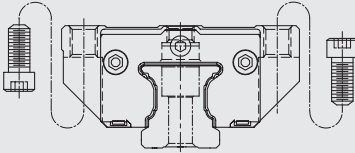
Type	Series/size	Layout	Height [mm]	Typical applications
High square type	CGH-CA CGH-HA		28 – 70	<ul style="list-style-type: none"> <li>– Woodworking</li> <li>– Machining centres</li> <li>– NC lathes</li> <li>– Grinding machines</li> <li>– Precision milling machines</li> <li>– High performance cutting machines</li> </ul>
Low square type	CGL-CA CGL-HA		25 – 60	<ul style="list-style-type: none"> <li>– Automation technology</li> <li>– Transport technology</li> <li>– Measuring technology</li> <li>– Machines and devices with high required positioning accuracy</li> </ul>
Flange type	CGW-CA CGW-HA		24 – 60	

### 3.2.5 Profile rail types

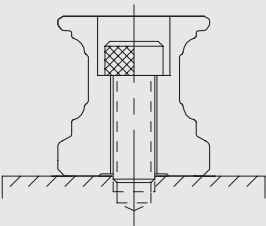
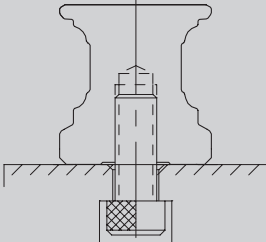
Fastening from above	Fastening from below
	
CGR_R	CGR_T

### 3.2.6 Preload

#### Definition

Each linear guideway can be preloaded via the ball size. The curve shows that the rigidity doubles at high preload. The CG series of linear guideways offers three standard preloads for different applications and conditions.

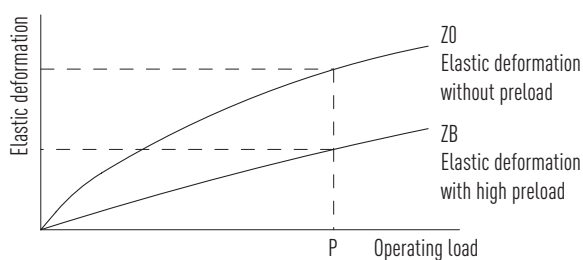

**Preload identifier**

Identifier	Preload		Application	Example applications
<b>Z0</b>	Slight preload	$0 - 0.02 C_{dyn}$	Constant load direction, little vibration, less accuracy required	<ul style="list-style-type: none"> <li>- Transport technology</li> <li>- Automatic packaging machines</li> <li>- X-Y axis in industrial machines</li> <li>- Welding machines</li> </ul>
<b>ZA</b>	Medium preload	$0.05 - 0.07 C_{dyn}$	High accuracy required	<ul style="list-style-type: none"> <li>- Machining centres</li> <li>- Z axes in industrial machines</li> <li>- Eroding machines</li> <li>- NC lathes</li> <li>- Precision X-Y table</li> <li>- Measuring technology</li> </ul>
<b>ZB</b>	High preload	Over $0.1 C_{dyn}$	High rigidity required, vibration and jolting	<ul style="list-style-type: none"> <li>- Machining centres</li> <li>- Grinding machines</li> <li>- NC lathes</li> <li>- Horizontal and vertical milling machines</li> <li>- Z-axis of machine tools</li> <li>- High performance cutting machines</li> </ul>

**3.2.7 Load ratings and torques**

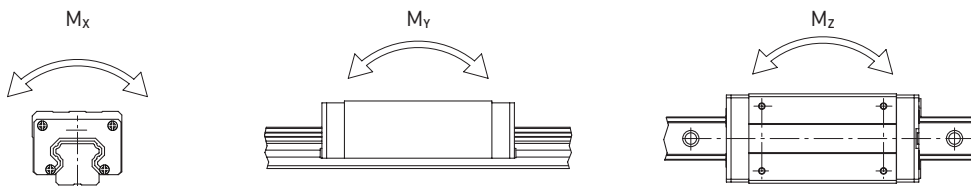

Series/Size	Dynamic load rating $C_{dyn}$ [N] <sup>1)</sup>	Static load rating $C_0$ [N]	Static moment [Nm]		
			$M_{0x}$	$M_{0y}$	$M_{0z}$
<b>CG_15C</b>	14,700	23,470	190	140	140
<b>CG_20C</b>	27,100	36,680	370	280	280
<b>CG_20H</b>	32,700	47,960	480	480	480
<b>CG_25C</b>	34,900	52,820	600	490	490
<b>CG_25H</b>	42,200	69,070	740	730	730
<b>CG_30C</b>	48,500	71,870	950	700	700
<b>CG_30H</b>	58,600	93,990	1,350	1,230	1,230
<b>CG_35C</b>	64,600	93,990	1,730	1,090	1,090
<b>CG_35H</b>	77,900	122,770	2,460	2,020	2,020
<b>CG_45C</b>	103,800	146,710	3,560	2,350	2,350
<b>CG_45H</b>	125,300	191,850	5,050	4,450	4,450

<sup>1)</sup> Dynamic load rating for 50,000 m travel path

# Linear guideways

## CG series

### 3.2.8 Rigidity

The rigidity depends on the preload. With the formula F 3.4, the deformation can be calculated depending on the rigidity.

F 3.4

$$\delta = \frac{P}{k}$$

$\delta$  Deformation [ $\mu\text{m}$ ]  
 $P$  Operating load [N]  
 $k$  Rigidity value [N/ $\mu\text{m}$ ]

Table 3.23 Radial rigidity of CG series

Load type	Series/ Size	Rigidity depending on the preload		
		Z0	ZA	ZB
Heavy load	CG_15C	240	290	330
	CG_20C	270	420	480
	CG_25C	340	440	570
	CG_30C	440	550	760
	CG_35C	470	610	800
	CG_45C	550	720	820
Super heavy load	CG_20H	360	470	530
	CG_25H	410	540	620
	CG_30H	490	640	730
	CG_35H	570	730	840
	CG_45H	740	960	1,100

Unit: N/ $\mu\text{m}$

## 3.2.9 Dimensions of the CG blocks

### 3.2.9.1 CGH

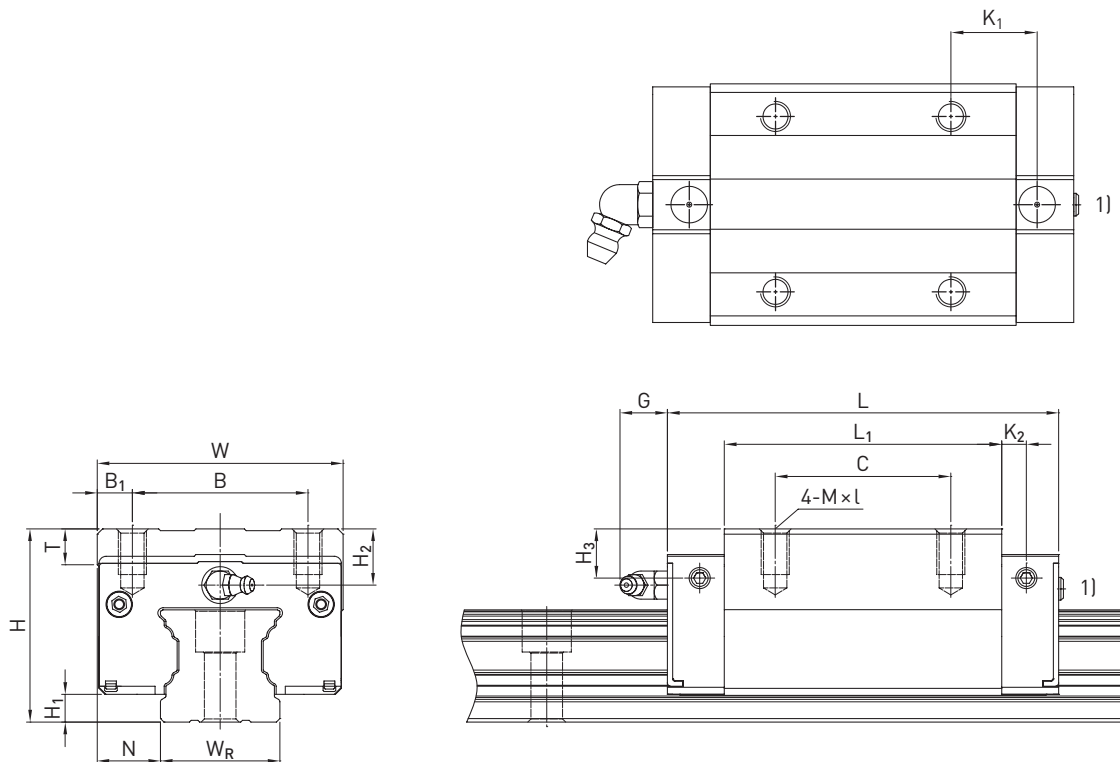

Table 3.24 Dimensions of the block

Series/size	Installation dimensions [mm]			Dimensions of the block [mm]													Load ratings [N]		Weight [kg]
	H	H <sub>1</sub>	N	W	B	B <sub>1</sub>	C	L <sub>1</sub>	L	K <sub>1</sub>	K <sub>2</sub>	G	M × l	T	H <sub>2</sub>	H <sub>3</sub>	C <sub>dyn</sub>	C <sub>0</sub>	
CGH15CA	28	4.1	9.5	34	26	4.0	26	39.6	58.2	10.8	4.25	6.0	M4 × 6	6.0	7.8	7.8	14,700	23,470	0.15
CGH20CA	30	4.6	12.0	44	32	6.0	36	52.5	74.9	12.45	5.50	6.0	M5 × 6	8.0	3.7	3.5	27,100	36,680	0.25
CGH20HA							50	68.5	90.9	13.45	32,700						47,960	0.33	
CGH25CA	40	6.1	12.5	48	35	6.5	35	61.0	84.0	17.4	5.00	12.0	M6 × 8	8.0	10.0	9.5	34,900	52,820	0.46
CGH25HA							50	78.4	101.4	18.6	42,200						69,070	0.59	
CGH30CA	45	7.0	16.0	60	40	10.0	40	69.0	97.4	19.75	8.70	12.0	M8 × 10	9.5	9.7	10.0	48,500	71,870	0.71
CGH30HA							60	91.5	119.9	21	58,600						93,990	0.94	
CGH35CA	55	7.6	18.0	70	50	10.0	50	79.0	111.4	22.6	7.00	12.0	M8 × 13	10.2	16.0	14.0	64,600	93,990	1.24
CGH35HA							72	103.4	135.8	23.8	77,900						122,770	1.62	
CGH45CA	70	9.7	20.5	86	60	13.0	60	97.2	137.6	23	8.70	12.9	M10 × 17	16.0	18.5	18.2	103,800	146,710	2.38
CGH45HA							80	133.6	174.0	31.2	125,300						191,850	3.01	

For dimensions of the rail, see Page 60, for standard as well as optional lubrication adapter, see Page 152.

<sup>1)</sup> Flat head screw protrudes 1 mm in all sizes.

# Linear guideways

## CG series

### 3.2.9.2 CGL

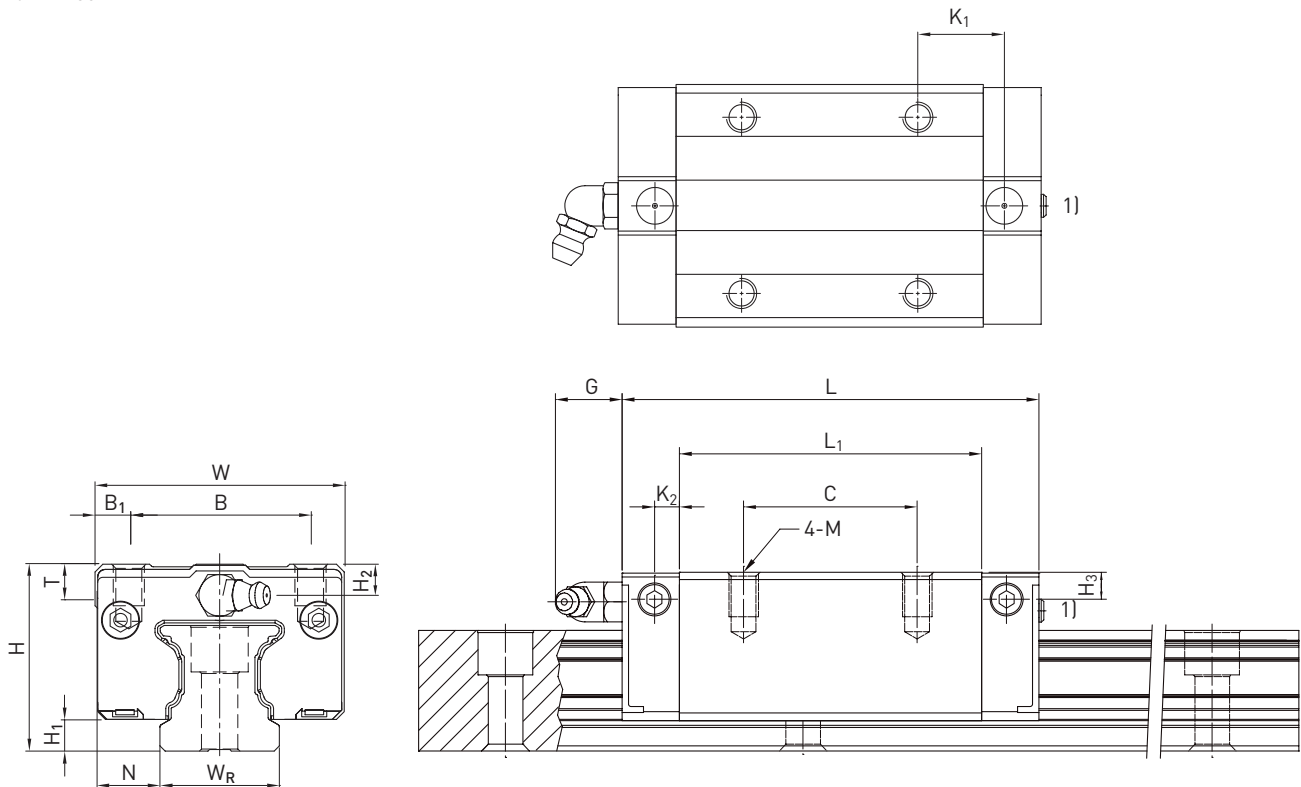

Table 3.25 Dimensions of the block

Series/size	Installation dimensions [mm]			Dimensions of the block [mm]													Load ratings [N]		Weight [kg]
	H	H <sub>1</sub>	N	W	B	B <sub>1</sub>	C	L <sub>1</sub>	L	K <sub>1</sub>	K <sub>2</sub>	G	M × l	T	H <sub>2</sub>	H <sub>3</sub>	C <sub>dyn</sub>	C <sub>0</sub>	
CGL15CA	24	4.1	9.5	34	26	4.0	26	39.6	58.2	10.8	4.25	6.0	M4 × 6	6.0	3.8	3.8	14,700	23,470	0.11
CGL25CA	36	6.1	12.5	48	35	6.5	35	61.0	84.0	17.4	5.00	12.0	M6 × 8	8.0	6.0	5.5	34,900	52,820	0.37
CGL25HA							50	78.4	101.4	18.6							42,200	69,070	0.47
CGL30CA	42	7.0	16.0	60	40	10.0	40	69.0	97.4	19.75	8.70	12.0	M8 × 10	9.5	6.7	7.0	48,500	71,870	0.61
CGL30HA							60	91.5	119.9	21.0							58,600	93,990	0.82
CGL35CA	48	7.6	18.0	70	50	10.0	50	79.0	111.4	22.6	7.00	12.0	M8 × 13	10.2	9.0	7.0	64,600	93,990	0.93
CGL35HA							72	103.4	135.8	23.8							77,900	122,770	1.22
CGL45CA	60	9.7	20.5	86	60	13.0	60	97.2	137.6	23.0	8.70	12.9	M10 × 17	16.0	8.5	8.1	103,800	146,710	1.72
CGL45HA							80	133.6	174.0	31.2							125,300	191,850	2.39

For dimensions of the rail, see Page 60, for standard as well as optional lubrication adapter, see Page 152.

<sup>1)</sup> Flat head screw protrudes 1 mm in all sizes.

## 3.2.9.3 CGW

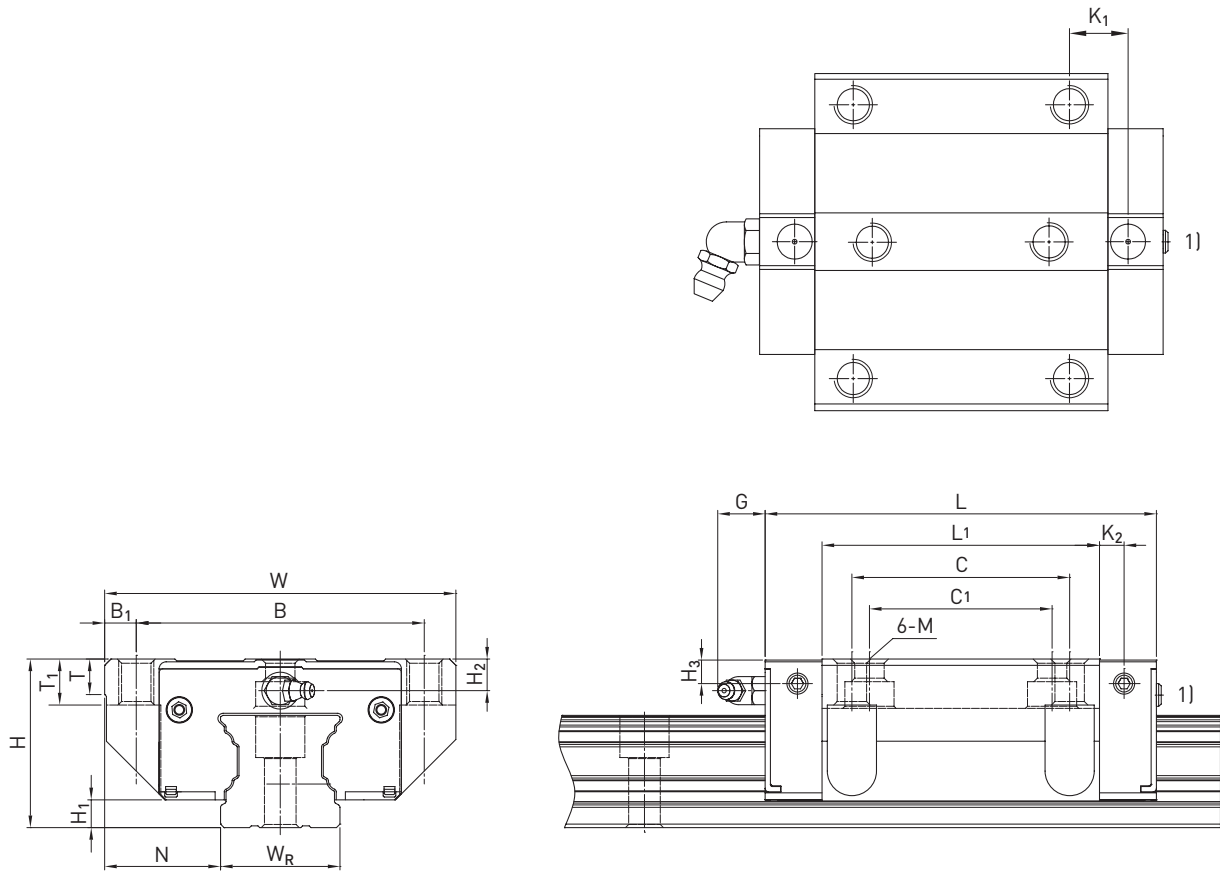

Table 3.26 Dimensions of the block

Series/size	Installation dimensions [mm]			Dimensions of the block [mm]														Load ratings [N]		Weight [kg]	
	H	H <sub>1</sub>	N	W	B	B <sub>1</sub>	C	C <sub>1</sub>	L <sub>1</sub>	L	K <sub>1</sub>	K <sub>2</sub>	G	M	T	T <sub>1</sub>	H <sub>2</sub>	H <sub>3</sub>	C <sub>dyn</sub>		C <sub>0</sub>
CGW15CC	24	4.1	16.0	47	38	4.5	30	26	39.6	58.2	8.8	4.25	6.0	M5	6.0	6.5	3.8	3.8	14,700	23,470	0.14
CGW20CC	30	4.6	21.5	63	53	5.0	40	35	52.5	74.9	10.45	5.50	6.0	M6	6.5	7.7	3.7	3.5	27,100	36,680	0.36
CGW20HC									68.5	90.9	18.45	32,700							47,960	0.47	
CGW25CC	36	6.1	23.5	70	57	6.5	45	40	61.0	84.0	12.4	5.00	12.0	M8	7.0	9.3	6.0	5.5	34,900	52,820	0.53
CGW25HC									78.4	101.4	21.1	42,200							69,070	0.68	
CGW30CC	42	7.0	31.0	90	72	9.0	52	44	69.0	97.4	13.75	8.70	12.0	M10	10.5	12.0	6.7	7.0	48,500	71,870	0.90
CGW30HC									91.5	119.9	25.0	58,600							93,990	1.19	
CGW35CC	48	7.6	33.0	100	82	9.0	62	52	79.0	111.4	16.6	7.00	12.0	M10	10.1	13.1	9.0	7.0	64,600	93,990	1.37
CGW35HC									103.4	135.8	28.8	77,900							122,770	1.79	
CGW45CC	60	9.7	37.5	120	100	10.0	80	60	97.2	137.6	13.0	8.70	12.9	M12	15.1	15.0	8.5	8.1	103,800	146,710	2.45
CGW45HC									133.6	174.0	31.2	125,300							191,850	3.00	

For dimensions of the rail, see Page 60, for standard as well as optional lubrication adapter, see Page 152.

<sup>1)</sup> Flat head screw protrudes 1 mm in all sizes.

# Linear guideways

## CG series

### 3.2.10 Dimensions of the CG rail

#### 3.2.10.1 Dimensions CGR\_R

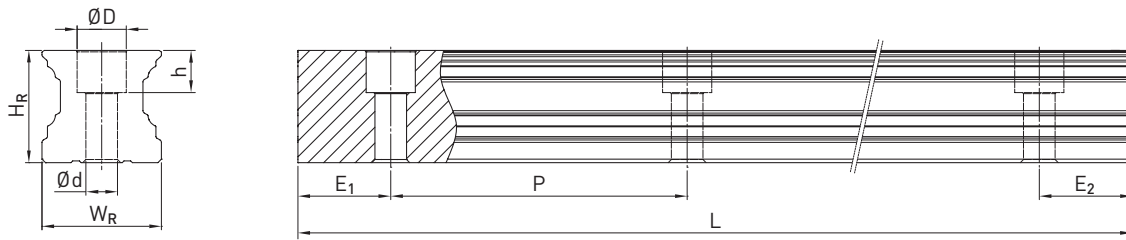

Table 3.27 Dimensions of profile rail CGR\_R

Series/ size	Assembly screw for rail [mm]	Dimensions of the rail [mm]						Max. length [mm]	Max. length E <sub>1</sub> = E <sub>2</sub> [mm]	Min. length [mm]	E <sub>1/2</sub> min [mm] <sup>1)</sup>	E <sub>1/2</sub> min [mm] <sup>2)</sup>	E <sub>1/2</sub> max [mm]	Weight [kg/m]
		W <sub>R</sub>	H <sub>R</sub>	D	h	d	P							
CGR15R	M4 × 20	15	16.20	7.5	5.9	4.5	60	4,000	3,900	72	6	14	54	1.58
CGR20R	M5 × 25	20	20.55	9.5	8.5	6.0	60	4,000	3,900	74	7	16	53	2.48
CGR25R	M6 × 30	23	24.25	11.0	9.0	7.0	60	4,000	3,900	76	8	17	52	3.38
CGR30R	M8 × 35	28	28.35	14.0	12.4	9.0	80	4,000	3,920	98	9	18	71	5.10
CGR35R	M8 × 40	34	31.85	14.0	12.0	9.0	80	4,000	3,920	98	9	24	71	7.14
CGR45R	M12 × 50	45	39.85	20.0	17.0	14.0	105	4,000	3,885	129	12	27	93	11.51

<sup>1)</sup> E<sub>1/2</sub> min without cover strip and with cover strip (clamp: steel clamp)

<sup>2)</sup> E<sub>1/2</sub> min with cover strip (clamp: front clamping screw)

#### 3.2.10.2 Dimensions CGR\_T

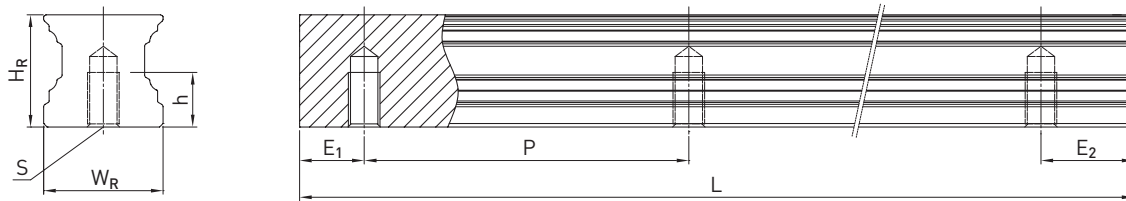

Table 3.28 Dimensions of profile rail CGR\_T

Series/size	Dimensions of the rail [mm]					Max. length [mm]	Max. length E <sub>1</sub> = E <sub>2</sub> [mm]	Min. length [mm]	E <sub>1/2</sub> min [mm] <sup>1)</sup>	E <sub>1/2</sub> min [mm] <sup>2)</sup>	E <sub>1/2</sub> max [mm]	Weight [kg/m]
	W <sub>R</sub>	H <sub>R</sub>	S	h	P							
CGR15T	15	16.20	M5	8	60	4,000	3,900	72	6	14	54	1.58
CGR20T	20	20.55	M6	10	60	4,000	3,900	74	7	15	53	2.48
CGR25T	23	24.25	M6	12	60	4,000	3,900	76	8	15	52	3.38
CGR30T	28	28.35	M8	15	80	4,000	3,920	98	9	16	71	5.10
CGR35T	34	31.85	M8	17	80	4,000	3,920	98	9	22	71	7.14
CGR45T	45	39.85	M12	24	105	4,000	3,885	129	12	24	93	11.51

<sup>1)</sup> E<sub>1/2</sub> min without cover strip and with cover strip (clamp: steel clamp)

<sup>2)</sup> E<sub>1/2</sub> min with cover strip (clamp: front clamping screw)

Note:

1. The tolerance for E is +0,5 to -1 mm for standard, for joint connections 0 to -0.3 mm.
2. If no information is provided on the E<sub>1/2</sub> dimensions, the maximum number of mounting holes is determined taking into account E<sub>1/2</sub> min.
3. The rails are shortened to the desired length. If no information on the E<sub>1/2</sub> dimensions is provided, then the rails are manufactured symmetrically.

### 3.2.10.3 Calculation of the length of profile rails

HIWIN offers profile rails in customised lengths. To make sure the end of the profile rail does not become unstable, the value E should not exceed half the distance between the mounting holes (P). At the same time, the value  $E_{1/2}$  should be between  $E_{1/2 \text{ min}}$  and  $E_{1/2 \text{ max}}$  so that the mounting hole does not break out.

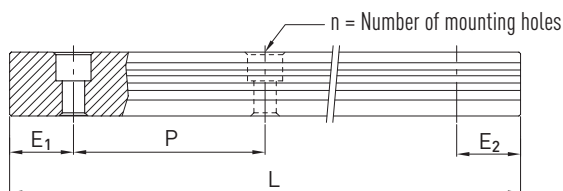

F 3.5

$$L = (n - 1) \times P + E_1 + E_2$$

L Total length of the profile rail [mm]  
 n Number of mounting holes  
 P Distance between two mounting holes [mm]  
 $E_{1/2}$  Distance from the centre of the last mounting hole to the end of the profile rail [mm].

### 3.2.10.4 Cover caps for mounting holes of profile rails

The cover caps are used to keep the mounting holes free of chips and dirt. The standard plastic cover caps accompany each profile rail. Optional cover caps have to be ordered separately.



Table 3.29 Cover caps for mounting holes of profile rails

Rail	Screw	Article number			Ø D [mm]	Height H [mm]
		Plastic (200 units)	Brass <sup>1)</sup>	Steel <sup>1)</sup>		
CGR15R	M4	5-002218	5-001344	—	7.5	1.2
CGR20R	M5	5-002220	5-001350	5-001352	9.5	2.5
CGR25R	M6	5-002221	5-001355	5-001357	11.0	2.8
CGR30R	M8	5-002222	5-001360	5-001362	14.0	3.5
CGR35R	M8	5-002222	5-001360	5-001362	14.0	3.5
CGR45R	M12	5-002223	5-001324	5-001327	20.0	4.0

<sup>1)</sup> Not recommended for coated rails.

# Linear guideways

## CG series

### 3.2.10.5 Cover strip clamp

The optional cover strip is supplied with a steel clamp to secure the strip. Alternatively, the clamp can also be secured with a clamping screw on the front side. The stroke is shortened when the clamping screw is used on the front side, see assembly instructions



Fig. 3.1 Clamp: Steel

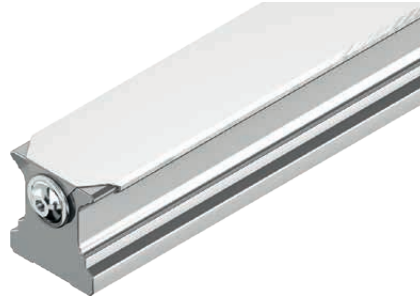

Fig. 3.2 Clamp: Front-side clamping screw

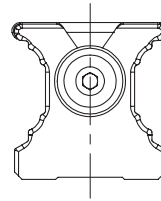
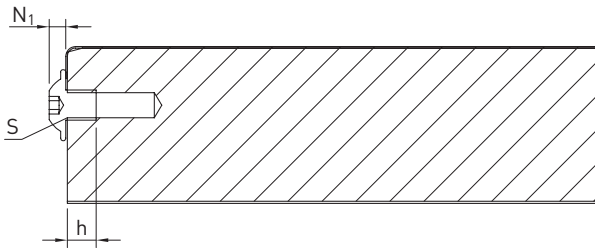

Table 3.30 Dimensions of profile rail with front-side clamping screw

Series/Size	S [mm]	h [mm]	N <sub>1</sub> [mm]
CG_15	M3	5	1.65
CG_20	M4	5	2.20
CG_25	M4	5	2.20
CG_30	M4	5	2.20
CG_35	M6	9	3.30
CG_45	M6	9	3.30

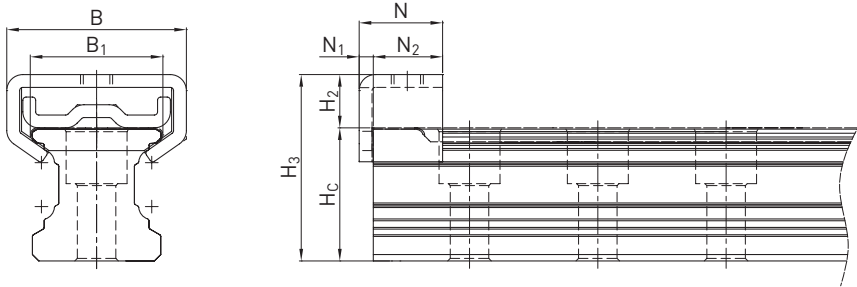

Table 3.32 Dimensions of profile rail with steel clamp

Series/Size	H <sub>3</sub> [mm]	H <sub>c</sub> [mm]	H <sub>2</sub> [mm]	N [mm]	N <sub>1</sub> [mm]	N <sub>2</sub> [mm]	B [mm]	B <sub>1</sub> [mm]
CG_15	20.09	16.70	3.9	15	2.2	12.8	21.0	15.8
CG_20	29.05	20.75	8.3	13	2.2	10.8	28.0	20.7
CG_25	34.42	24.45	10.0	15	2.2	12.8	30.6	23.9
CG_30	37.80	28.55	9.3	12	2.2	9.8	34.0	28.9
CG_35	43.20	30.40	13.0	18	2.2	15.8	35.4	34.8
CG_45	52.66	39.85	13.7	18	2.2	15.8	53.6	45.6

### 3.2.11 Sealing systems

Different sealing systems are available for HIWIN blocks. You can find an overview on Page 24. The following table shows the total length of the blocks with different sealing systems. Appropriate sealing systems are available for these sizes.

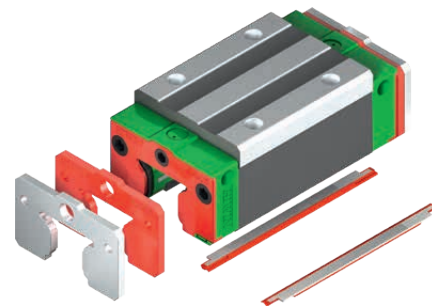

Table 3.31 Total length of block with different sealing systems

Series/size	Total length L (including screws)			
	SS	ZZX	SW	ZWX
CG15C	58.2	61.2	63.2	66.2
CG20C	74.9	77.9	79.9	82.9
CG20H	90.9	93.9	95.9	98.9
CG25C	84.0	90.0	89.0	95.0
CG25H	101.4	107.4	106.4	112.4
CG30C	97.4	103.4	102.8	108.8
CG30H	119.9	125.9	125.3	131.3
CG35C	111.4	117.4	116.8	122.8
CG35H	135.8	141.8	141.2	147.2
CG45C	137.6	143.6	143.0	149.0
CG45H	174.0	180.0	179.4	185.4

Unit: mm

# Linear guideways

## CG series

### 3.2.12 Long-term lubrication unit

Further information on the lubrication unit can be found in the general information in section "Long-term lubrication unit" on Page 17. The following drawing shows the dimension (L) for a single-sided lubrication unit. The dimension for a double-sided lubrication unit results from the dimension L + T. The EC lubrication unit is available with the sealing systems named in the table.

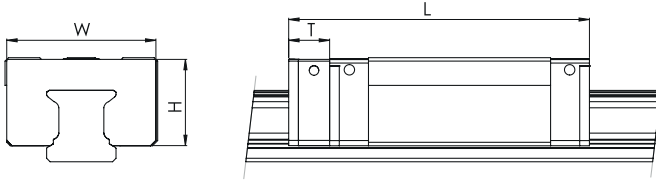

Table 3.33 Dimensions of the block with lubrication unit EC

Model	Dimensions of the block [mm]				Max. running performance <sup>2)</sup> [km] EC single-sided	Max. running performance <sup>2)</sup> [km] EC double-sided
	W	H	T	L <sub>SS/sw</sub> <sup>1)</sup>		
CG_15C	33.4	19.35	10.8	69.0	10,000	20,000
CG_20C	43.0	24.85	11.8	86.7	10,000	20,000
CG_20H	43.0	24.85	11.8	102.7	10,000	20,000
CG_25C	47.0	28.90	12.5	96.5	10,000	20,000
CG_25H	47.0	28.90	12.5	113.9	10,000	20,000

<sup>1)</sup> Total length with selected dust protection. SS = Standard dust protection

<sup>2)</sup> Further details can be found in the assembly instructions in the "Lubrication" chapter

**3.2.13 Tolerances depending on the accuracy class**

The CG series are available in five accuracy classes according to the parallelism between block and rail, height accuracy H and width accuracy N. The selection of the accuracy class is determined by the requirements of the machine.

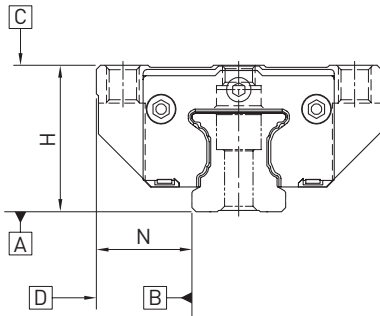

**3.2.12.1 Parallelism**

Parallelism of locating surfaces D and B of the block and rail and of top block surface C to mounting surface A of the rail. Ideal installation of the linear guideway and the measurement in the centre of the block are prerequisites.

Table 3.34 Tolerance of parallelism between block and profile rail

Rail length [mm]	Accuracy class				
	C	H	P	SP	UP
- 100	12	7	3	2	2
100 - 200	14	9	4	2	2
200 - 300	15	10	5	3	2
300 - 500	17	12	6	3	2
500 - 700	20	13	7	4	2
700 - 900	22	15	8	5	3
900 - 1100	24	16	9	6	3
1100 - 1500	26	18	11	7	4
1500 - 1900	28	20	13	8	4
1900 - 2500	31	22	15	10	5
2500 - 3100	33	25	18	11	6
3100 - 3600	36	27	20	14	7
3600 - 4000	37	28	21	15	7

Unit: µm

# Linear guideways

## CG series

### 3.2.13.1 Accuracy – height and width

#### Height tolerance of H

Permissible absolute dimension deviation of height H, measured between the centre of bolting surface C and rail underside A, with any position of the block on the rail.

#### Height variance of H

Permissible deviation of height H between several blocks on one rail, measured at the same position of the rail.

#### Width tolerance of N

Permissible absolute dimension deviation of width N, measured between the centre of bolting surfaces D and B, with any position of the block on the rail.

#### Width variance of N

Permissible deviation of width N between several blocks on one rail, measured at the same position of the rail.

Table 3.35 Tolerances of width and height

Series/size	Accuracy class	Height tolerance of H ( $T_H$ )	Width tolerance of N	Height variance of H	Width variance of N
<b>CG_15, 20</b>	C (Normal)	$\pm 0.1$	$\pm 0.1$	0.02	0.02
	H (high)	$\pm 0.03$	$\pm 0.03$	0.01	0.01
	P (precision)	$0/-0.03^{1)}$ $\pm 0.015^{2)}$	$0/-0.03^{1)}$ $\pm 0.015^{2)}$	0.006	0.006
	SP (super precision)	$0/-0.015$	$0/-0.015$	0.004	0.004
	UP (ultra precision)	$0/-0.008$	$0/-0.008$	0.003	0.003
<b>CG_25, 30, 35</b>	C (Normal)	$\pm 0.1$	$\pm 0.1$	0.02	0.03
	H (high)	$\pm 0.04$	$\pm 0.04$	0.015	0.015
	P (precision)	$0/-0.04^{1)}$ $\pm 0.02^{2)}$	$0/-0.04^{1)}$ $\pm 0.02^{2)}$	0.007	0.007
	SP (super precision)	$0/-0.02$	$0/-0.02$	0.005	0.005
	UP (ultra precision)	$0/-0.01$	$0/-0.01$	0.003	0.003
<b>CG_45</b>	C (Normal)	$\pm 0.1$	$\pm 0.1$	0.03	0.03
	H (high)	$\pm 0.05$	$\pm 0.05$	0.015	0.02
	P (precision)	$0/-0.05^{1)}$ $\pm 0.025^{2)}$	$0/-0.05^{1)}$ $\pm 0.025^{2)}$	0.007	0.01
	SP (super precision)	$0/-0.03$	$0/-0.03$	0.005	0.007
	UP (ultra precision)	$0/-0.02$	$0/-0.02$	0.003	0.005

Unit: mm

<sup>1)</sup> Assembled linear guideway

<sup>2)</sup> Unassembled linear guideway

### 3.2.13.2 Permissible tolerances of the mounting surface

Once the requirements for the accuracy of the mounting surfaces are met, the high accuracy, rigidity and service life of the CG series linear guideways are achieved.

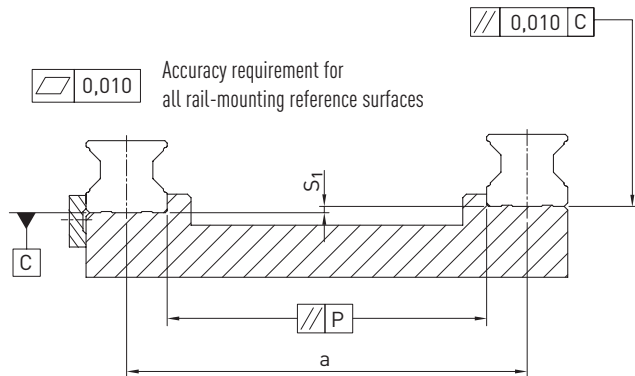

#### Tolerance of parallelism of reference surface (P)

Table 3.36 Maximum tolerance for parallelism (P)

Series/Size	Preload class		
	Z0	ZA	ZB
CG_15	9	5	4
CG_20	11	7	5
CG_25	12	8	6
CG_30	14	9	7
CG_35	15	11	8
CG_45	19	12	10

Unit:  $\mu\text{m}$

#### Tolerance of height of reference surface ( $S_1$ )

$$F 3.6 \quad S_1 = a \times K - T_H$$

- $S_1$  Maximum height tolerance [mm]
- $a$  Distance between rails [mm]
- $K$  Coefficient of height tolerance
- $T_H$  Tolerance of height according to Table 3.35

Table 3.37 Coefficient of height tolerance (K)

Series/Size	Preload class		
	Z0	ZA	ZB
CG_15 – CG_45	$2.8 \times 10^{-4}$	$1.7 \times 10^{-4}$	$1.2 \times 10^{-4}$

Note: If  $S_1 < 0$ , select another tolerance class!

# Linear guideways

## CG series

### Height tolerance for mounting surface on block

- The height tolerance of the reference surface when two or more blocks are used in parallel ( $S_2$ )

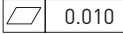
 Accuracy requirement for all block-mounting reference surfaces

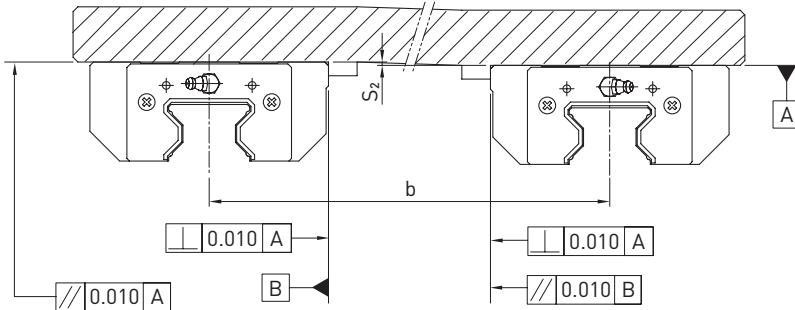

**F 3.7**  $S_2 = b \times K$

$S_2$  Maximum height tolerance [mm]  
 $b$  Distance between blocks [mm]  
 $K$  Coefficient of height tolerance

- The height tolerance of the reference surface when two or more blocks are used in parallel ( $S_3$ )

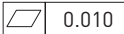
 Accuracy requirement for all block-mounting reference surfaces

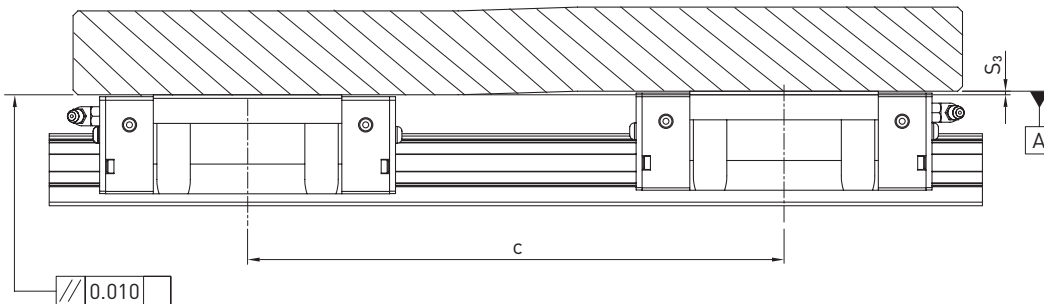

**F 3.8**  $S_3 = c \times K$

$S_3$  Maximum height tolerance [mm]  
 $c$  Distance between blocks [mm]  
 $K$  Coefficient of height tolerance

Table 3.38 Coefficient of height tolerance (K)

Series/Size	Load type	
	CG_C	CG_H
CG_15 - CG_45	$4.2 \times 10^{-5}$	$3.0 \times 10^{-5}$

### 3.2.14 Shoulder heights and edge roundings

Inaccurate shoulder heights and edge roundings of mounting surfaces impair accuracy and may conflict with the block or rail profile. The following shoulder heights and edge profiles must be observed to avoid assembly problems.

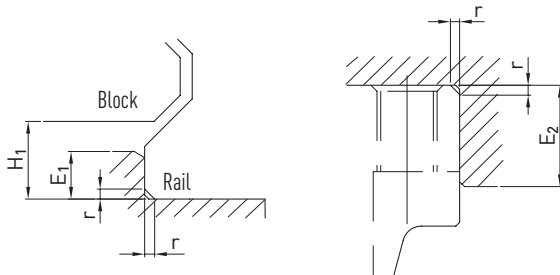

Table 3.39 Shoulder heights and edge roundings

Series/Size	Max. radius of edges $r$	Shoulder height of the reference edge of rail $E_1$	Shoulder height of the reference edge of block $E_2$	Clearance height under block $H_1$
CG_15	0.5	3.0	4.0	4.3
CG_20	0.5	3.5	5.0	4.6
CG_25	1.0	5.0	5.0	6.1
CG_30	1.0	5.0	5.0	7.0
CG_35	1.0	6.0	6.0	7.6
CG_45	1.0	8.0	8.0	9.5

Unit: mm

# Linear guideways

## EG/QE series

---

### 3.3 EG/QE series

#### 3.3.1 Properties of the EG and QE series linear guideways

Flat type, specially for applications with limited installation space. The HIWIN linear guideways of the EG series with four ball tracks are well-suited for applications with tight installation space due to their low installation height. Nevertheless, the EG series has the same properties as the HG series: high load capacity, low displacement forces and high efficiency. The ball retainers prevent the balls from falling out when pulled from the profile rail during installation of the blocks.

The models of the QE series with SynchMotion™ technology offer all the advantages of the standard EG series. Controlled movement of the balls at a defined distance also results in improved synchronous performance, higher reliable travel speeds, extended lubrication intervals and less running noise. Since the installation dimensions of the QE blocks are identical to those of the EG blocks, they are also mounted on the EGR standard rail and can thus be easily interchanged. For further information, see Page 26.

#### 3.3.2 Layout of EG/QE series

- Four-row recirculating ball bearing guide
- 45° contact angle of the ball tracks
- The ball retainers prevent the balls from falling out when the block is removed
- Different sealing variants, depending on application area
- 6 connection options for lubricating nipples or lubrication adapters
- SynchMotion™ technology (QE series)

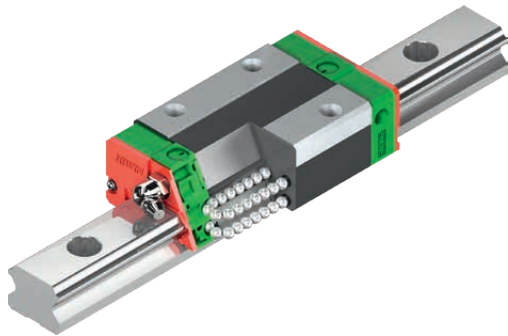

Layout of EG series

#### Advantages:

- Backlash-free
- Exchangeable
- High accuracy
- Highly resilient in all loading directions
- Low friction losses even with preload from optimised ball tracks and 2-point contact

#### 3.3.3 Order codes of EG/QE series

For EG/QE linear guideways, there is a distinction made between assembled and non-assembled models. The dimensions of both models are the same. The main difference is that, in the unassembled models, blocks and profile rails can be freely interchanged. Block and profile rail can be ordered separately and mounted by the customer. Their accuracy reaches class P.

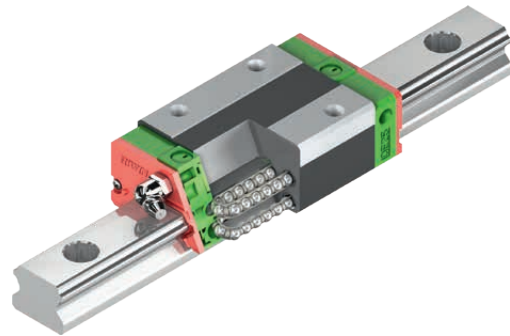

Layout of QE series

#### Additional advantages of QE series:

- Improved synchronous performance
- Optimised for higher travel speeds
- Extended relubrication intervals
- Reduced running noise
- Higher dynamic load rating

## Order code for linear guideway (assembled)

EG W 25 C C 2 R 1600 ZA H 2 DD E2 CTS

Series:

EG

QE

Type:

W: Flange block

H: Square block

Size:

EG: 15, 20, 25, 30, 35

QE: 15, 20, 25, 30, 35

Load class:

S: Average load

C: Heavy load

Block fastening:

A: From above

C: From above or below

Number of blocks per profile rail

Profile rail mounting:

R: From above

T: From below

U: From above with large assembly hole (EG/QE15, EG/QE30)

Coating:

None: No coating

CTS, CZS, CCB

None: Standard

E2: Long-term lubrication unit

SE: Steel deflector<sup>3)</sup>

Dust protection<sup>2)</sup>:

None: Standard (SS)

ZZ, DD, KK

Rails per axis<sup>1)</sup>

Accuracy class:

C, H, P, SP, UP

Preload identifier:

Z0, ZA, ZB

Profile rail length [mm]

## Order number of block (not assembled)

EG W 25 C C Z0 H ZZ E2

Series:

EG

QE

Type:

W: Flange block

H: Square block

Size:

EG: 15, 20, 25, 30, 35

QE: 15, 20, 25, 30, 35

Load class:

S: Average load

C: Heavy load

None: Standard

E2: Long-term lubrication unit

Dust protection<sup>2)</sup>:

None: Standard (SS)

ZZ, DD, KK

Accuracy class:

C, H, P

Preload identifier:

Z0, ZA, ZB

Block fastening:

A: From above

C: From above or below

## Order number of profile rail (not assembled)

EG R 25 R 1200 H CTS

EG series

Profile rail

Size:

15, 20, 25, 30, 35

Coating:

None: No coating

CTS, CZS, CCB

Accuracy class:

C, H, P

Profile rail length [mm]

Profile rail mounting:

R: From above

T: From below

U: From above with large assembly hole (EG/QE15, EG/QE30)

Note:

<sup>1)</sup> The number 2 is also a quantity indication, i.e. one piece of the article described above consists of one pair of rails.

No number is given for single profile rails. In the case of multi-part rails, the joint is offset as standard.

<sup>2)</sup> An overview of the individual sealing systems can be found on Page 24

<sup>3)</sup> Only available for EG 20 and EG 25

# Linear guideways

EG/QE series

### 3.3.4 Block types

HIWIN offers block and flange blocks for its linear guideways. Due to the low installation height and the larger mounting surface, flange blocks are better suited for large loads.

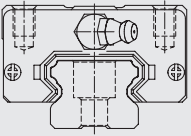
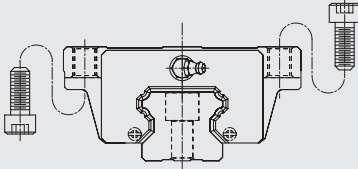
Type	Series/size	Layout	Height [mm]	Typical applications
<b>Square type</b>	EGH-SA EGH-CA		24 – 48	<ul style="list-style-type: none"> <li>- Machining centres</li> <li>- NC lathes</li> <li>- Grinding machines</li> <li>- Precision milling machines</li> <li>- High performance cutting machines</li> <li>- Automation technology</li> <li>- Transport technology</li> <li>- Measuring technology</li> <li>- Machines and devices with high required positioning accuracy</li> </ul>
<b>Flange type</b>	EGW-SC EGW-CC			

### 3.3.5 Profile rail types

In addition to profile rails with standard fastening from above, HIWIN also offers rails for fastening from below.

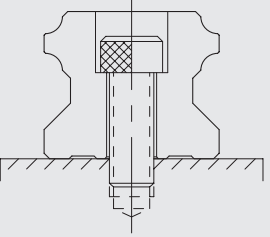
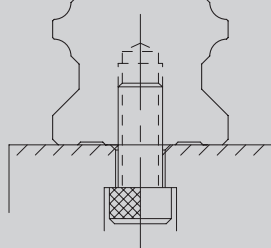
Fastening from above	Fastening from below
	
EGR_R	EGR_T

### 3.3.6 Preload

#### Definition

Each linear guideway can be preloaded via the ball size. The curve shows that the rigidity doubles at high preload. The EG/QE series of linear guideways offers three standard preloads for different applications and conditions.

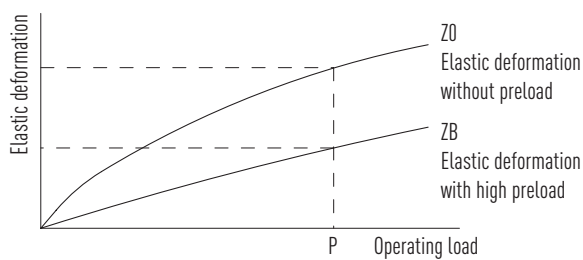

## Preload identifier

Table 3.42 Preload identifier

Identifier	Preload		Application	Example applications
ZO	Slight preload	$0 - 0.02 C_{dyn}$	Constant load direction, little vibration, less accuracy required	<ul style="list-style-type: none"> <li>Transport technology</li> <li>Automatic packaging machines</li> <li>X-Y axis in industrial machines</li> <li>Welding machines</li> </ul>
ZA	Medium preload	$0.03 - 0.05 C_{dyn}$	High accuracy required	<ul style="list-style-type: none"> <li>Machining centres</li> <li>Z axes in industrial machines</li> <li>Eroding machines</li> <li>NC lathes</li> <li>Precision X-Y table</li> <li>Measuring technology</li> </ul>
ZB	High preload	$0.06 - 0.08 C_{dyn}$	High rigidity required, vibration and jolting	<ul style="list-style-type: none"> <li>Machining centres</li> <li>Grinding machines</li> <li>NC lathes</li> <li>Horizontal and vertical milling machines</li> <li>Z-axis of machine tools</li> <li>High performance cutting machines</li> </ul>

### 3.3.7 Load ratings and torques

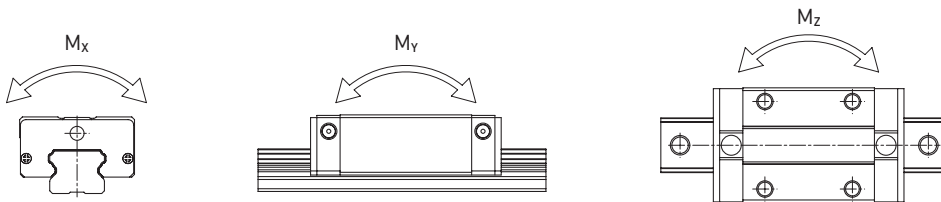

Table 3.43 Load ratings and torques for EG/QE series

Series/Size	Dynamic load rating $C_{dyn}$ [N] <sup>1)</sup>	Static load rating $C_0$ [N]	Static moment [Nm]		
			$M_{0x}$	$M_{0y}$	$M_{0z}$
EG_15S	5,350	9,400	80	40	40
QE_15S	8,560	8,790	70	30	30
EG_15C	7,830	16,190	130	100	100
QE_15C	12,530	15,280	120	90	90
EG_20S	7,230	12,740	130	60	60
QE_20S	11,570	12,180	130	50	50
EG_20C	10,310	21,130	220	160	160
QE_20C	16,500	20,210	210	150	150
EG_25S	11,400	19,500	230	120	120
QE_25S	18,240	18,900	220	100	100
EG_25C	16,270	32,400	380	320	320
QE_25C	26,030	31,490	370	290	290
EG_30S	16,420	28,100	400	210	210
QE_30S	26,270	27,820	400	180	180
EG_30C	23,700	47,460	680	550	550
QE_30C	37,920	46,630	670	510	510
EG_35S	22,660	37,380	560	310	310
QE_35S	36,390	36,430	610	330	330
EG_35C	33,350	64,840	980	690	690
QE_35C	51,180	59,280	1,000	750	750

<sup>1)</sup> Dynamic load rating for 50,000 m travel path

# Linear guideways

## EG/QE series

### 3.3.8 Rigidity

The rigidity depends on the preload. With the formula F 3.9, the deformation can be calculated depending on the rigidity.

F 3.9

$$\delta = \frac{P}{k}$$

- δ Deformation [μm]
- P Operating load [N]
- k Rigidity value [N/μm]

Table 3.44 Radial rigidity of EG/QE series

Load type	Series/size	Rigidity depending on the preload		
		Z0	ZA	ZB
Average load	EG_15S	105	126	141
	QE_15S	96	115	128
	EG_20S	126	151	168
	QE_20S	116	139	153
	EG_25S	156	187	209
	QE_25S	137	165	184
	EG_30S	184	221	246
	QE_30S	169	203	226
	EG_35S	221	265	295
	QE_35S	214	257	287
Heavy load	EG_15C	172	206	230
	QE_15C	157	187	209
	EG_20C	199	238	266
	QE_20C	183	219	245
	EG_25C	246	296	329
	QE_25C	219	263	293
	EG_30C	295	354	395
	QE_30C	271	326	363
	EG_35C	354	425	474
QE_35C	333	399	445	

Unit: N/μm

### 3.3.9 Dimensions of the EG/QE blocks

#### 3.3.9.1 EGH/QEH

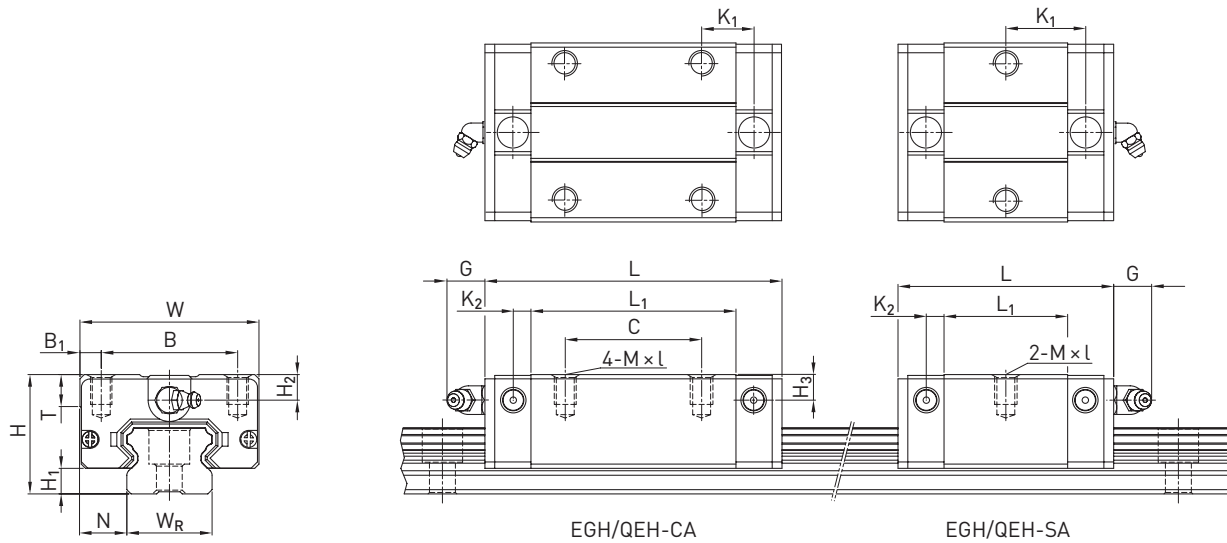

Table 3.45 Dimensions of the block

Series/size	Installation dimensions [mm]			Dimensions of the block [mm]													Load ratings [N]		Weight [kg]
	H	H <sub>1</sub>	N	W	B	B <sub>1</sub>	C	L <sub>1</sub>	L	K <sub>1</sub>	K <sub>2</sub>	G	M × l	T	H <sub>2</sub>	H <sub>3</sub>	C <sub>dyn</sub>	C <sub>0</sub>	
EGH15SA	24	4.5	9.5	34	26	4.0	—	23.1	40.1	14.80	3.50	5.7	M4 × 6	6.0	5.5	6.0	5,350	9,400	0.09
EGH15CA							26	39.8	56.8	10.15							7,830	16,190	0.15
QEH15SA	24	4.0	9.5	34	26	4.0	—	23.1	40.1	14.80	3.50	5.7	M4 × 6	6.0	5.5	6.0	8,560	8,790	0.09
QEH15CA							26	39.8	56.8	10.15							12,530	15,280	0.15
EGH20SA	28	6.0	11.0	42	32	5.0	—	29.0	50.0	18.75	4.15	12.0	M5 × 7	7.5	6.0	6.0	7,230	12,740	0.15
EGH20CA							32	48.1	69.1	12.30							10,310	21,130	0.24
QEH20SA	28	6.0	11.0	42	32	5.0	—	29.0	50.0	18.75	4.15	12.0	M5 × 7	7.5	6.0	6.5	11,570	12,180	0.15
QEH20CA							32	48.1	69.1	12.30							16,500	20,210	0.23
EGH25SA	33	7.0	12.5	48	35	6.5	—	35.5	59.1	21.90	4.55	12.0	M6 × 9	8.0	8.0	8.0	11,400	19,500	0.25
EGH25CA							35	59.0	82.6	16.15							16,270	32,400	0.41
QEH25SA	33	6.2	12.5	48	35	6.5	—	35.5	60.1	21.90	5.00	12.0	M6 × 9	8.0	8.0	8.0	18,240	18,900	0.24
QEH25CA							35	59.0	83.6	16.15							26,030	31,490	0.40
EGH30SA	42	10.0	16.0	60	40	10.0	—	41.5	69.5	26.75	6.00	12.0	M8 × 12	9.0	8.0	9.0	16,420	28,100	0.45
EGH30CA							40	70.1	98.1	21.05							23,700	47,460	0.76
QEH30SA	42	10.0	16.0	60	40	10.0	—	41.5	67.5	25.75	6.00	12.0	M8 × 12	9.0	8.0	9.0	26,270	27,820	0.44
QEH30CA							40	70.1	96.1	20.05							37,920	46,630	0.75
EGH35SA	48	11.0	18.0	70	50	10.0	—	45.0	75.0	28.50	7.00	12.0	M8 × 12	10.0	8.5	8.5	22,660	37,380	0.74
EGH35CA							50	78.0	108.0	20.00							33,350	64,840	1.10
QEH35SA	48	11.0	18.0	70	50	10.0	—	51.0	76.0	30.30	6.25	12.0	M8 × 12	10.0	8.5	8.5	36,390	36,430	0.58
QEH35CA							50	83.0	108.0	21.30							51,180	59,280	0.90

For dimensions of the rail, see Page 77, for standard as well as optional lubrication adapter, see Page 152.

# Linear guideways

## EG/QE series

### 3.3.9.2 EGW/QEW

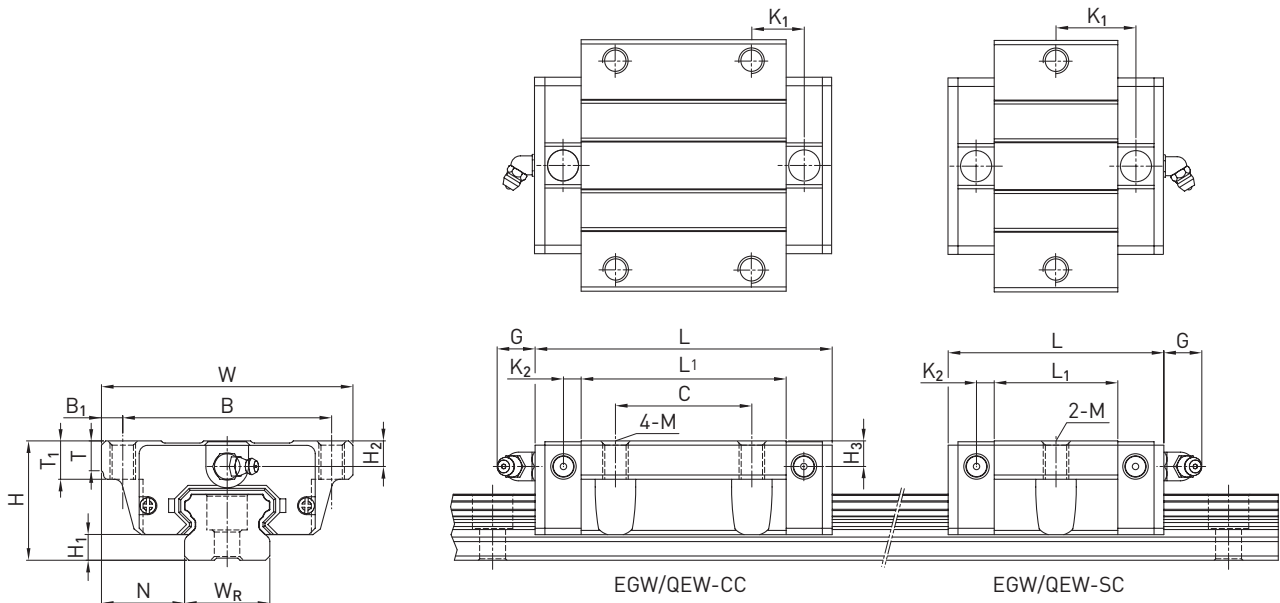

Table 3.46 Dimensions of the block

Series/size	Installation dimensions [mm]			Dimensions of the block [mm]														Load ratings [N]		Weight [kg]
	H	H <sub>1</sub>	N	W	B	B <sub>1</sub>	C	L <sub>1</sub>	L	K <sub>1</sub>	K <sub>2</sub>	G	M	T	T <sub>1</sub>	H <sub>2</sub>	H <sub>3</sub>	C <sub>dyn</sub>	C <sub>0</sub>	
EGW15SC	24	4.5	18.5	52	41	5.5	—	23.1	40.1	14.80	3.50	5.7	M5	5.0	7	5.5	6.0	5,350	9,400	0.12
EGW15CC							26	39.8	56.8	10.15								7,830	16,190	0.21
QEW15SC	24	4.0	18.5	52	41	5.5	—	23.1	40.1	14.80	3.50	5.7	M5	5.0	—	5.5	6.0	8,560	8,790	0.12
QEW15CC							26	39.8	56.8	10.15								12,530	15,280	0.21
EGW20SC	28	6.0	19.5	59	49	5.0	—	29.0	50.0	18.75	4.15	12.0	M6	7.0	9	6.0	6.0	7,230	12,740	0.19
EGW20CC							32	48.1	69.1	12.30								10,310	21,130	0.32
QEW20SC	28	6.0	19.5	59	49	5.0	—	29.0	50.0	18.75	4.15	12.0	M6	7.0	—	6.0	6.5	11,570	12,180	0.19
QEW20CC							32	48.1	69.1	12.30								16,500	20,210	0.31
EGW25SC	33	7.0	25.0	73	60	6.5	—	35.5	59.1	21.90	4.55	12.0	M8	7.5	10	8.0	8.0	11,400	19,500	0.35
EGW25CC							35	59.0	82.6	16.15								16,270	32,400	0.59
QEW25SC	33	6.2	25.0	73	60	6.5	—	35.5	60.1	21.90	5.00	12.0	M8	7.5	—	8.0	8.0	18,240	18,900	0.34
QEW25CC							35	59.0	83.6	16.15								26,030	31,490	0.58
EGW30SC	42	10.0	31.0	90	72	9.0	—	41.5	69.5	26.75	6.00	12.0	M10	7.0	10	8.0	9.0	16,420	28,100	0.62
EGW30CC							40	70.1	98.1	21.05								23,700	47,460	1.04
QEW30SC	42	10.0	31.0	90	72	9.0	—	41.5	67.5	25.75	6.00	12.0	M10	7.0	—	8.0	9.0	26,270	27,820	0.61
QEW30CC							40	70.1	96.1	20.05								37,920	46,630	1.03
EGW35SC	48	11.0	33.0	100	82	9.0	—	45.0	75.0	28.50	7.00	12.0	M10	10.0	13	8.5	8.5	22,660	37,380	0.91
EGW35CC							50	78.0	108.0	20.00								33,350	64,840	1.40
QEW35SC	48	11.0	33.0	100	82	9.0	—	51.0	76.0	30.30	6.25	12.0	M10	10.0	13	8.5	8.5	36,390	36,430	0.77
QEW35CC							50	83.0	108.0	21.30								51,180	59,280	1.19

For dimensions of the rail, see Page 77, for standard as well as optional lubrication adapter, see Page 152.

### 3.3.10 Dimensions of the EG rail

The EG profile rail is used for both the EG and QE blocks.

#### 3.3.10.1 Dimensions EGR\_R

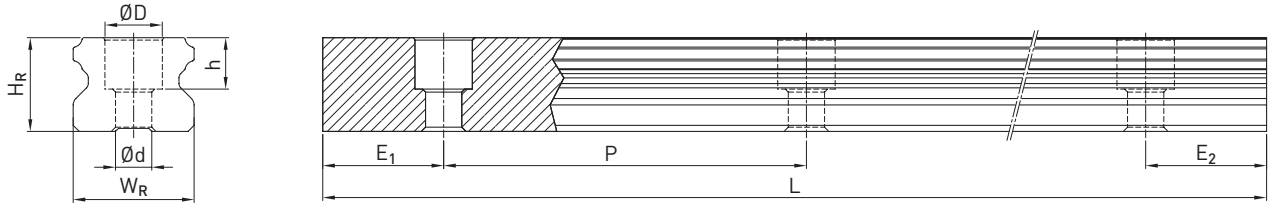

Table 3.47 Dimensions of profile rail EGR\_R

Series/size	Assembly screw for rail [mm]	Dimensions of the rail [mm]						Max. length [mm]	Max. length $E_1 = E_2$ [mm]	Min. length [mm]	$E_{1/2}$ min [mm]	$E_{1/2}$ max [mm]	Weight [kg/m]
		$W_R$	$H_R$	D	h	d	P						
EGR15R	M3 × 16	15	12.5	6.0	4.5	3.5	60	4,000	3,900	70	5	54	1.25
EGR20R	M5 × 20	20	15.5	9.5	8.5	6.0	60	4,000	3,900	74	7	53	2.08
EGR25R	M6 × 25	23	18.0	11.0	9.0	7.0	60	4,000/5,600	3,900/5,520 <sup>1)</sup>	76	8	52	2.67
EGR30R	M6 × 30	28	23.0	11.0	9.0	7.0	80	4,000/5,600	3,900/5,520 <sup>1)</sup>	96	8	71	4.35
EGR35R	M8 × 35	34	27.5	14.0	12.0	9.0	80	4,000	3,920	98	9	71	6.14

#### 3.3.10.2 Dimensions EGR\_U (large mounting holes)

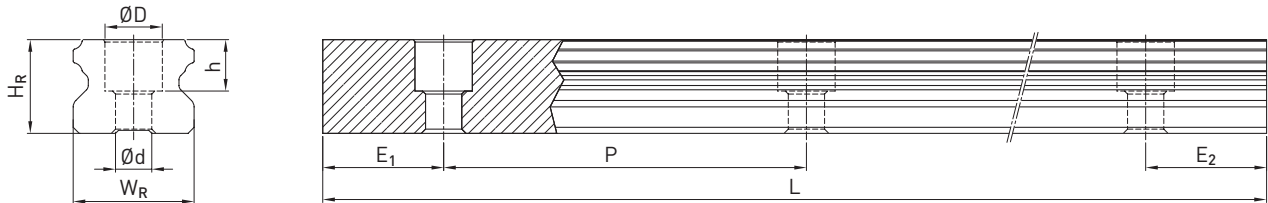

Table 3.48 Dimensions of profile rail EGR\_U

Series/size	Assembly screw for rail [mm]	Dimensions of the rail [mm]						Max. length [mm]	Max. length $E_1 = E_2$ [mm]	Min. length [mm]	$E_{1/2}$ min [mm]	$E_{1/2}$ max [mm]	Weight [kg/m]
		$W_R$	$H_R$	D	h	d	P						
EGR15U	M4 × 16	15	12.5	7.5	5.3	4.5	60	4,000	3,900	72	6	54	1.23
EGR30U	M8 × 30	28	23.0	14.0	12.0	9.0	80	4,000	3,920	98	9	71	4.23

Note:

1. The tolerance for E is +0,5 to -1 mm for standard, for joint connections 0 to -0.3 mm.
2. If no information is provided on the  $E_{1/2}$  dimensions, the maximum number of mounting holes is determined taking into account  $E_{1/2}$  min.
3. The rails are shortened to the desired length. If no information on the  $E_{1/2}$  dimensions is provided, then the rails are manufactured symmetrically.

# Linear guideways

EG/QE series

## 3.3.10.3 Dimensions EGR\_T (profile rail fastening from below)

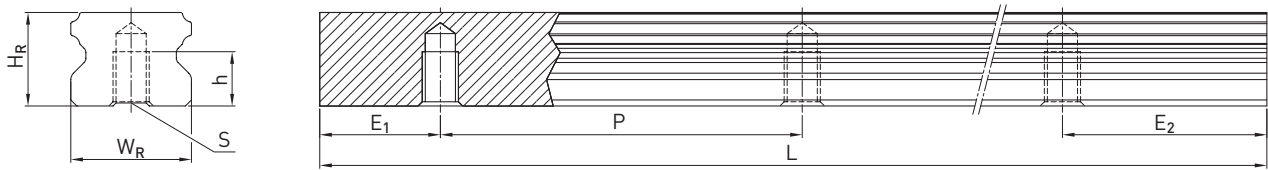

Table 3.49 Dimensions of profile rail EGR\_T

Series/size	Dimensions of the rail [mm]					Max. length [mm]	Max. length $E_1 = E_2$ [mm]	Min. length [mm]	$E_{1/2}$ min [mm]	$E_{1/2}$ max [mm]	Weight [kg/m]
	$W_R$	$H_R$	S	h	P						
EGR15T	15	12.5	M5	7	60	4,000	3,900	70	5	54	1.26
EGR20T	20	15.5	M6	9	60	4,000	3,900	74	7	53	2.15
EGR25T	23	18.0	M6	10	60	4,000	3,900	76	8	52	2.79
EGR30T	28	23.0	M8	14	80	4,000	3,920	96	8	71	4.42
EGR35T	34	27.5	M8	17	80	4,000	3,920	98	9	71	6.34

Note:

1. The tolerance for E is +0.5 to -1 mm for standard, for joint connections 0 to -0.3 mm.
2. If no information is provided on the  $E_{1/2}$  dimensions, the maximum number of mounting holes is determined taking into account  $E_{1/2}$  min.
3. The rails are shortened to the desired length. If no information on the  $E_{1/2}$  dimensions is provided, then the rails are manufactured symmetrically.

## 3.3.10.4 Calculation of the length of profile rails

HIWIN offers profile rails in customised lengths. To make sure the end of the profile rail does not become unstable, the value E should not exceed half the distance between the mounting holes (P). At the same time, the value  $E_{1/2}$  should be between  $E_{1/2}$  min and  $E_{1/2}$  max so that the mounting hole does not break out.

$$F 3.10 \quad L = (n - 1) \times P + E_1 + E_2$$

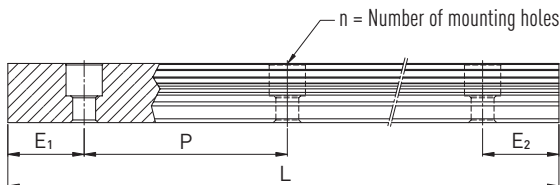

- L Total length of the profile rail [mm]
- n Number of mounting holes
- P Distance between two mounting holes [mm]
- $E_{1/2}$  Distance from the centre of the last mounting hole to the end of the profile rail [mm].

## 3.3.10.5 Cover caps for mounting holes of profile rails

The cover caps are used to keep the mounting holes free of chips and dirt. The standard plastic cover caps accompany each profile rail. Optional cover caps have to be ordered separately.



Table 3.50 Cover caps for mounting holes of profile rails

Rail	Screw	Article number			Ø D [mm]	Height H [mm]
		Plastic (200 units)	Brass <sup>1)</sup>	Steel <sup>1)</sup>		
EGR15R	M3	5-002217	5-001340	—	6.0	1.2
EGR20R	M5	5-002220	5-001350	5-001352	9.5	2.5
EGR25R	M6	5-002221	5-001355	5-001357	11.0	2.8
EGR30R	M6	5-002221	5-001355	5-001357	11.0	2.8
EGR35R	M8	5-002222	5-001360	5-001362	14.0	3.5
EGR15U	M4	5-002218	5-001344	—	7.5	1.2
EGR30U	M8	5-002222	5-001360	5-001362	14.0	3.5

<sup>1)</sup> Not recommended for coated rails.

### 3.3.11 Sealing systems

Different sealing systems are available for HIWIN blocks. You can find an overview on Page 24. The following table shows the total length of the blocks with different sealing systems. Appropriate sealing systems are available for these sizes.

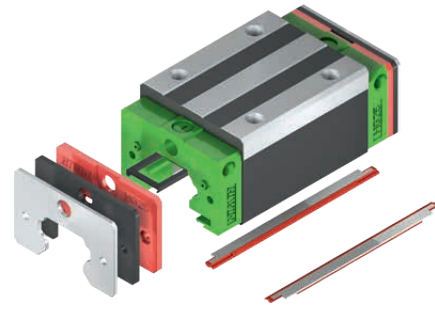

Table 3.51 Total length of block with different sealing systems

Series/size	Total length L (including screws)			
	SS	DD	ZZ	KK
EG_15S	40.1	44.1	41.7	45.7
QE_15S	40.1	44.1	42.1	46.1
EG_15C	56.8	60.8	58.4	62.4
QE_15C	56.8	60.8	58.8	62.8
EG_20S	50.0	54.0	51.6	55.6
QE_20S	50.0	54.0	52.0	56.0
EG_20C	69.1	73.1	70.7	74.7
QE_20C	69.1	73.1	71.1	75.1
EG_25S	59.1	63.1	61.1	65.1
QE_25S	60.1	65.1	62.1	67.1
EG_25C	82.6	86.6	84.6	88.6
QE_25C	83.6	88.6	85.6	90.6
EG_30S	69.5	73.5	71.5	75.5
QE_30S	67.5	72.5	69.5	74.5
EG_30C	98.1	102.1	100.1	104.1
QE_30C	96.1	101.1	98.1	103.1
EG_35S	75.0	79.0	78.0	82.0
QE_35S	76.0	80.0	79.0	83.0
EG_35C	108.0	112.0	111.0	115.0
QE_35C	108.0	112.0	111.0	115.0

Unit: mm

#### 3.3.11.1 Designation of the seal sets

The seal sets are always shipped complete with the installation materials and include the supplemental parts for the standard seal.

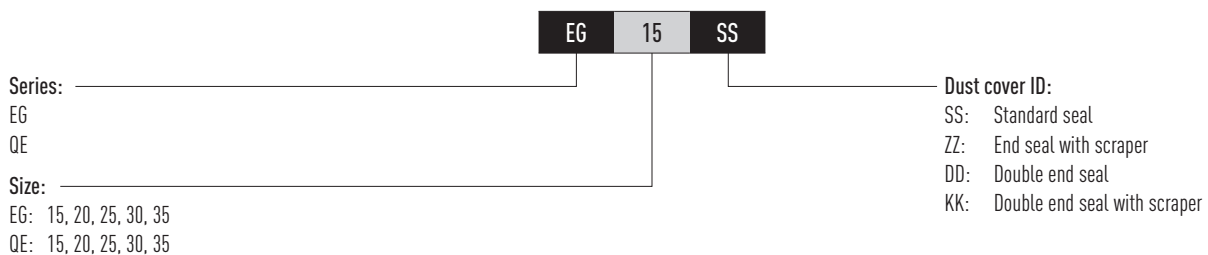

# Linear guideways

EG/QE series

## 3.3.12 Long-term lubrication unit

Further information on the lubrication unit can be found in the general information in section "2.6.3 Long-term lubrication unit" on Page 17.

The following drawing shows the dimension (L) for a single-sided lubrication unit. (standard) The dimension for a double-sided lubrication unit results from the dimension  $L + V + T$ . The E2 long-term lubrication unit is available with the sealing systems named in the table.

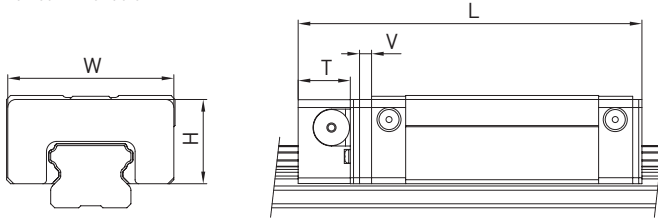

Table 3.52 Dimensions of the block with lubrication unit E2

Model	Dimensions of the block [mm]								Max. running performance <sup>2)</sup> [km] E2 single-sided	Max. running performance <sup>2)</sup> [km] E2 double-sided
	W	H	T	V	L <sub>SS</sub> <sup>1)</sup>	L <sub>ZZ</sub> <sup>1)</sup>	L <sub>DD</sub> <sup>1)</sup>	L <sub>KK</sub> <sup>1)</sup>		
EG_15S	33.3	18.7	11.5	3.0	54.6	56.2	58.6	60.2	10,000	20,000
QE_15S	33.3	19.2	11.5	3	54.6	-	-	-	20,000	30,000
EG_15C	33.3	18.7	11.5	3.0	71.3	72.9	75.3	76.9	10,000	20,000
QE_15C	33.3	19.2	11.5	3	71.3	-	-	-	20,000	30,000
EG_20S	41.3	20.9	13.0	3.0	66.0	67.6	70.0	71.6	10,000	20,000
QE_20S	41.3	20.9	13	3	66.0	-	-	-	20,000	30,000
EG_20C	41.3	20.9	13.0	3.0	85.1	86.7	89.1	90.7	10,000	20,000
QE_20C	41.3	20.9	13	3	85.1	-	-	-	20,000	30,000
EG_25S	47.3	24.9	13.0	3.0	75.1	77.1	79.1	81.1	10,000	20,000
QE_25S	47.3	24.9	13	3	76.1	-	-	-	20,000	30,000
EG_25C	47.3	24.9	13.0	3.0	98.6	100.6	102.6	104.6	10,000	20,000
QE_25C	47.3	24.9	13	3	99.6	-	-	-	20,000	30,000
EG_30S	59.3	31.0	13.0	3.0	85.5	87.5	89.5	91.5	10,000	20,000
QE_30S	59.3	31	13	3	83.5	-	-	-	20,000	30,000
EG_30C	59.3	31.0	13.0	3.0	114.1	116.1	118.1	120.1	10,000	20,000
QE_30C	59.3	31	13	3	112.1	-	-	-	20,000	30,000
QE_35S	68	35.5	13	3	92.0	-	-	-	20,000	30,000
QE_35C	68	35.5	13	3	124.0	-	-	-	20,000	30,000

<sup>1)</sup> Total length depending on the selected dust protection. SS = Standard dust protection

<sup>2)</sup> Further details can be found in the assembly instructions in the "Lubrication" chapter

**3.3.13 Tolerances depending on the accuracy class**

The EG and QE series are available in five accuracy classes according to the parallelism between block and rail, height accuracy H and width accuracy N. The selection of the accuracy class is determined by the requirements of the machine.

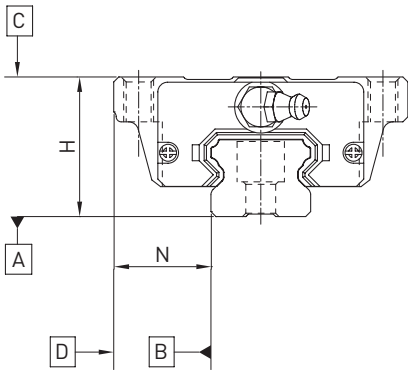

**3.3.13.1 Parallelism**

Parallelism of locating surfaces D and B of the block and rail and of top block surface C to mounting surface A of the rail. Ideal installation of the linear guideway and the measurement in the centre of the block are prerequisites.

Table 3.53 Tolerance of parallelism between block and profile rail

Rail length [mm]	Accuracy class				
	C	H	P	SP	UP
- 100	12	7	3	2	2
100 – 200	14	9	4	2	2
200 – 300	15	10	5	3	2
300 – 500	17	12	6	3	2
500 – 700	20	13	7	4	2
700 – 900	22	15	8	5	3
900 – 1100	24	16	9	6	3
1100 – 1500	26	18	11	7	4
1500 – 1900	28	20	13	8	4
1900 – 2500	31	22	15	10	5
2500 – 3100	33	25	18	11	6
3100 – 3600	36	27	20	14	7
3600 – 4000	37	28	21	15	7

Unit: µm

# Linear guideways

EG/QE series

## 3.3.13.2 Accuracy – height and width

### Height tolerance of H

Permissible absolute dimension deviation of height H, measured between the centre of bolting surface C and rail underside A, with any position of the block on the rail.

### Height variance of H

Permissible deviation of height H between several blocks on one rail, measured at the same position of the rail.

### Width tolerance of N

Permissible absolute dimension deviation of width N, measured between the centre of bolting surfaces D and B, with any position of the block on the rail.

### Width variance of N

Permissible deviation of width N between several blocks on one rail, measured at the same position of the rail.

Table 3.54 Tolerances of width and height

Series/size	Accuracy class	Height tolerance of H	Width tolerance of N	Height variance of H	Width variance of N
EG_15, 20 QE_15, 20	C (Normal)	$\pm 0.1$	$\pm 0.1$	0.02	0.02
	H (high)	$\pm 0.03$	$\pm 0.03$	0.01	0.01
	P (precision)	$0/-0.03^{1)}$ $\pm 0.015^{2)}$	$0/-0.03^{1)}$ $\pm 0.015^{2)}$	0.006	0.006
	SP (super precision)	$0/-0.015$	$0/-0.015$	0.004	0.004
	UP (ultra precision)	$0/-0.008$	$0/-0.008$	0.003	0.003
EG_25, 30, 35 QE_25, 30, 35	C (Normal)	$\pm 0.1$	$\pm 0.1$	0.02	0.03
	H (high)	$\pm 0.04$	$\pm 0.04$	0.015	0.015
	P (precision)	$0/-0.04^{1)}$ $\pm 0.02^{2)}$	$0/-0.04^{1)}$ $\pm 0.02^{2)}$	0.007	0.007
	SP (super precision)	$0/-0.02$	$0/-0.02$	0.005	0.005
	UP (ultra precision)	$0/-0.01$	$0/-0.01$	0.003	0.003

Unit: mm

<sup>1)</sup> Assembled linear guideway

<sup>2)</sup> Unassembled linear guideway

## 3.3.13.3 Permissible tolerances of the mounting surface

Once the requirements for the accuracy of the mounting surfaces are met, the high accuracy, rigidity and service life of the EG and QE series linear guideways are achieved.

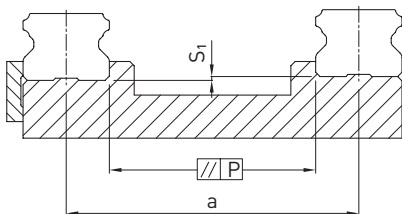

### Tolerance of parallelism of reference surface (P):

Table 3.55 Maximum tolerance for parallelism (P)

Series/Size	Preload class		
	Z0	ZA	ZB
EG/QE_15	25	18	—
EG/QE_20	25	20	18
EG/QE_25	30	22	20
EG/QE_30	40	30	27
EG/QE_35	50	35	30

Unit:  $\mu\text{m}$

### Tolerance of height of reference surface ( $S_1$ ):

F 3.11  $S_1 = a \times K$

- $S_1$  Maximum height tolerance [mm]
- $a$  Distance between rails [mm]
- $K$  Coefficient of height tolerance

Table 3.56 Coefficient of height tolerance (K)

Series/Size	Preload class		
	Z0	ZA	ZB
EG/QE_15	$2.6 \times 10^{-4}$	$1.7 \times 10^{-4}$	—
EG/QE_20	$2.6 \times 10^{-4}$	$1.7 \times 10^{-4}$	$1.0 \times 10^{-4}$
EG/QE_25	$2.6 \times 10^{-4}$	$1.7 \times 10^{-4}$	$1.4 \times 10^{-4}$
EG/QE_30	$3.4 \times 10^{-4}$	$2.2 \times 10^{-4}$	$1.8 \times 10^{-4}$
EG/QE_35	$4.2 \times 10^{-4}$	$3.0 \times 10^{-4}$	$2.4 \times 10^{-4}$

### 3.3.14 Shoulder heights and edge roundings

Inaccurate shoulder heights and edge roundings of mounting surfaces impair accuracy and may conflict with the block or rail profile. The following shoulder heights and edge profiles must be observed to avoid assembly problems.

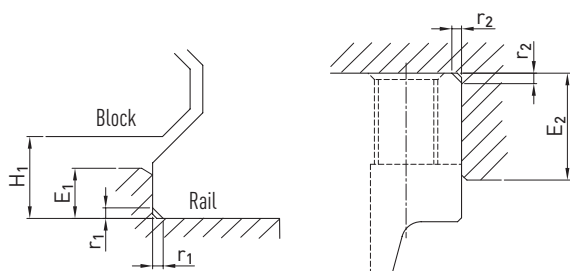

Table 3.57 Shoulder heights and edge roundings

Series/Size	Max. radius of edges $r_1$	Max. radius of edges $r_2$	Shoulder height of the reference edge of rail $E_1$	Shoulder height of the reference edge of block $E_2$	Clearance height under block $H_1$
EG/QE_15	0.5	0.5	2.7	5.0	4.5
EG/QE_20	0.5	0.5	5.0	7.0	6.0
EG/QE_25	1.0	1.0	5.0	7.5	7.0
EG/QE_30	1.0	1.0	7.0	7.0	10.0
EG_35	1.0	1.0	7.5	9.5	11.0
QE_35	1.0	1.5	7.5	9.5	11.0

Unit: mm

# Linear guideways

## WE/QW series

### 3.4 WE/QW series

#### 3.4.1 Properties of the WE and QW series linear guideway

Wide type, for maximum torque loads. The HIWIN linear guideways of the WE series are based on proven HIWIN technology. Due to their large rail width and low overall height, they enable a compact design and high torque capacity.

The models of the QW series with SynchMotion™ technology offer all the advantages of the standard WE series. Controlled movement of the balls at a defined distance also results in improved synchronous performance, higher reliable travel speeds, extended lubrication intervals and less running noise. Since the installation dimensions of the QW blocks are identical to those of the WE blocks, they are also mounted on the WER standard rail and can thus be easily interchanged. For further information, see Page 26.

#### 3.4.2 Layout of WE/QW series

- Four-row linear guideway
- 45° contact angle
- The ball retainers prevent the balls from falling out when the block is removed
- Low installation height
- Wide linear guideway for high torque capacity
- Large mounting surface on block
- SynchMotion™ technology (QW series)

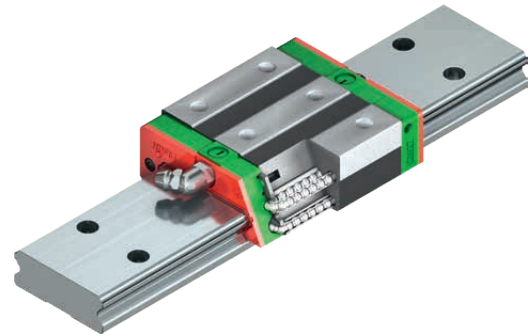
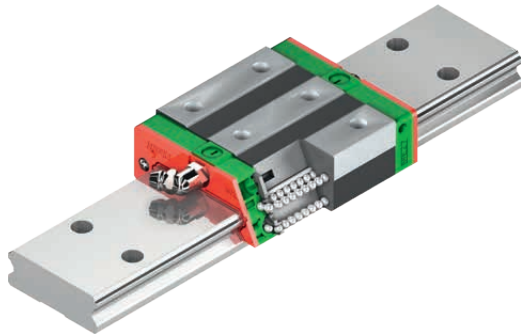

Layout of WE series

Layout of QW series

#### Advantages:

- Compact and cost-effective design due to high torque capacity
- High efficiency due to low friction losses

#### Additional advantages of QW series:

- Improved synchronous performance
- Optimised for higher travel speeds
- Extended relubrication intervals
- Reduced running noise
- Higher dynamic load rating

50% wider than standard series

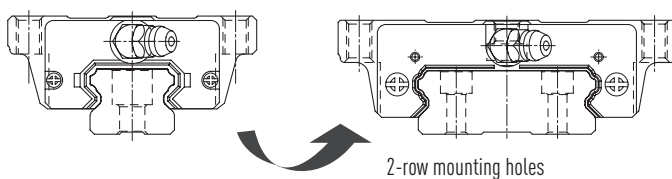

- The large-area mounting surface of the block supports the transmission of higher torques
- The 45° arrangement of the ball tracks allows for high loads from all directions

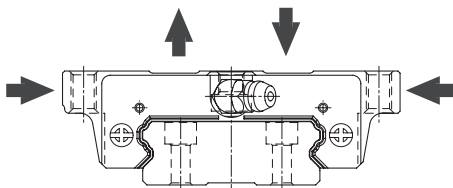

### 3.4.3 Order codes of WE/QW series

For WE/QW linear guideways, there is a distinction made between assembled and non-assembled models. The dimensions of both models are the same. The main difference is that, in the unassembled models, blocks and profile rails can be freely interchanged. Block and profile rail can be ordered separately and mounted by the customer. Their accuracy reaches class P.

#### Order code for linear guideway (assembled)

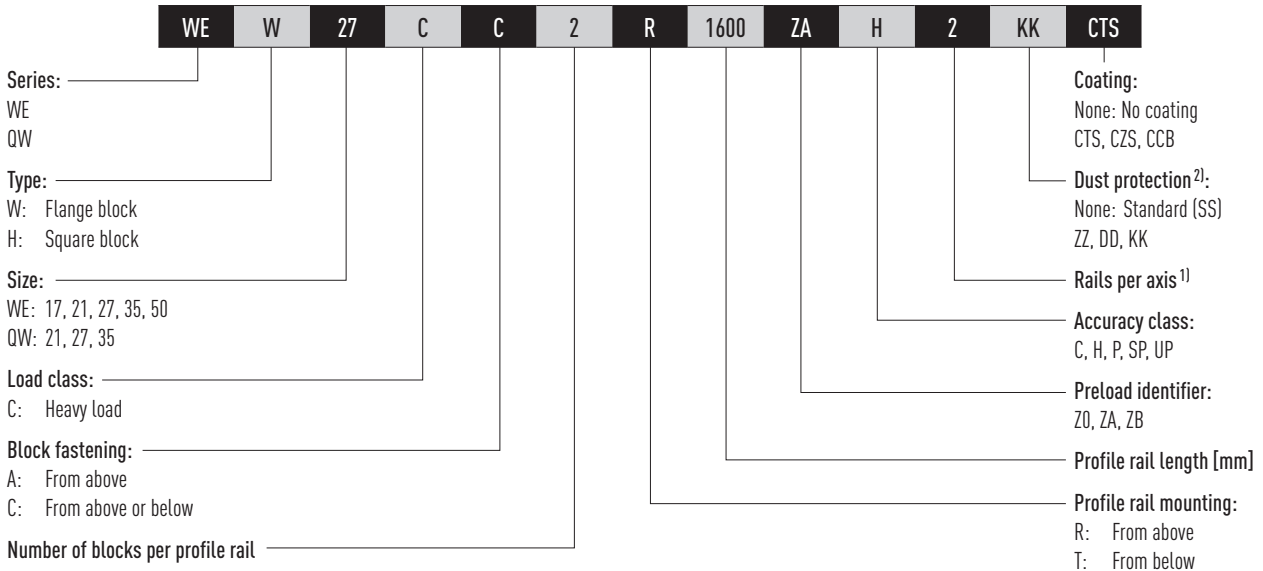

#### Order number of block (not assembled)

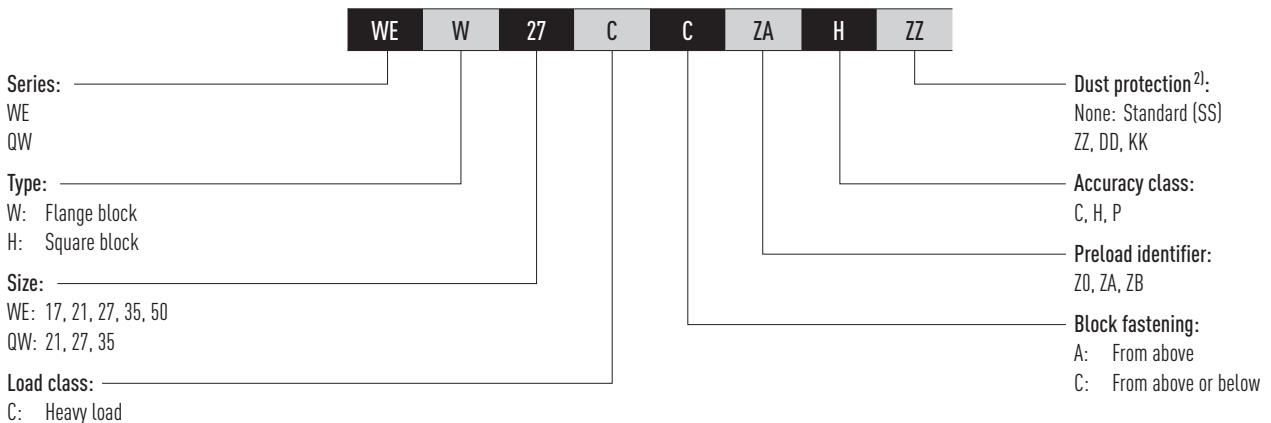

#### Order number of profile rail (not assembled)

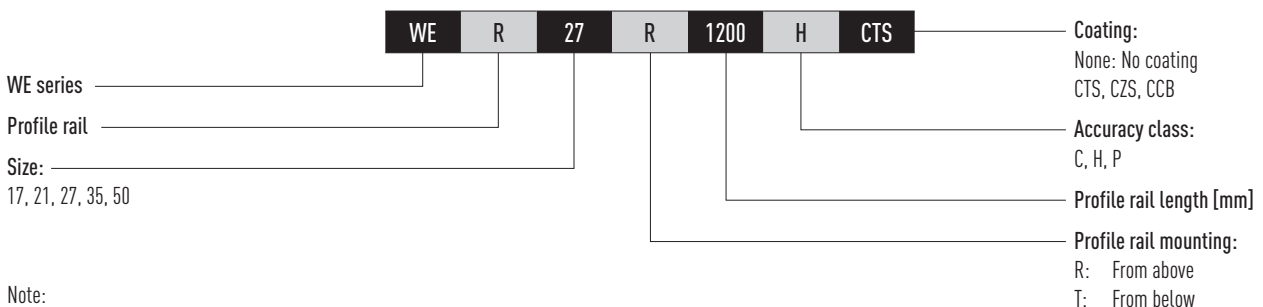

Note:

<sup>1)</sup> The number 2 is also a quantity indication, i.e. one piece of the article described above consists of one pair of rails.

No number is given for single profile rails. In the case of multi-part rails, the joint is offset as standard.

<sup>2)</sup> An overview of the individual sealing systems can be found on Page 24

# Linear guideways

## WE/QW series

### 3.4.4 Block types

HIWIN offers block and flange block versions. Due to the larger mounting surface, flange blocks are better suited for large loads.

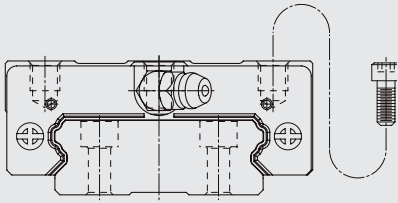
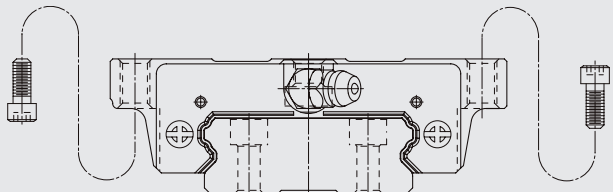
Type	Series/size	Layout	Height [mm]	Typical applications
Square type	WEH-CA QWH-CA		17 – 50	<ul style="list-style-type: none"> <li>Automation</li> <li>Handling industry</li> <li>Measuring and testing technology</li> <li>Semiconductor industry</li> <li>Injection moulding machines</li> <li>Linear axes</li> </ul>
Flange type	WEW-CC QWW-CC			

### 3.4.5 Preload

#### Definition

Each linear guideway can be preloaded via the ball size. The curve shows that the rigidity doubles at high preload. The WE/QW series of linear guideways offers three standard preloads for different applications and conditions.

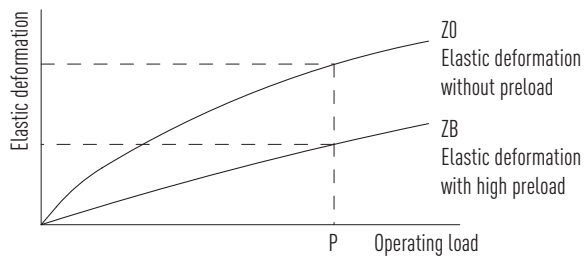

#### Preload identifier

Identifier	Preload		Application	Example applications
Z0	Slight preload	$0 - 0.02 C_{dyn}$	Constant load direction, little vibration, less accuracy required	<ul style="list-style-type: none"> <li>Transport technology</li> <li>Automatic packaging machines</li> <li>X-Y axis in industrial machines</li> <li>Welding machines</li> </ul>
ZA	Medium preload	$0.03 - 0.05 C_{dyn}$	High accuracy required	<ul style="list-style-type: none"> <li>Machining centres</li> <li>Z axes in industrial machines</li> <li>Eroding machines</li> <li>NC lathes</li> <li>Precision X-Y table</li> <li>Measuring technology</li> </ul>
ZB	High preload	$0.06 - 0.08 C_{dyn}$	High rigidity required, vibration and jolting	<ul style="list-style-type: none"> <li>Machining centres</li> <li>Grinding machines</li> <li>NC lathes</li> <li>Horizontal and vertical milling machines</li> <li>Z-axis of machine tools</li> <li>High performance cutting machines</li> </ul>

### 3.4.6 Load ratings and torques

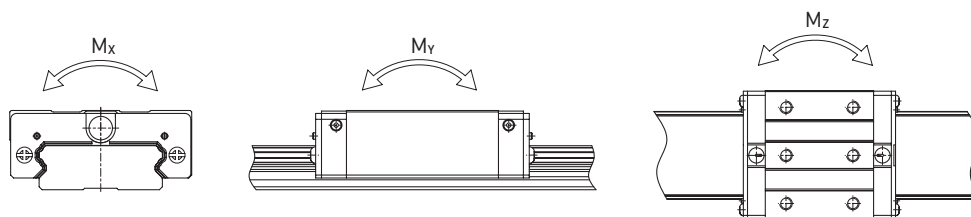

Table 3.60 Load ratings and torques for WE/QW series

Series/Size	Dynamic load rating $C_{dyn}$ [N] <sup>1)</sup>	Static load rating $C_0$ [N]	Static moment [Nm]		
			$M_{0x}$	$M_{0y}$	$M_{0z}$
WE_17C	5,230	9,640	150	62	62
WE_21C	7,210	13,700	230	100	100
QW_21C	9,000	12,100	210	90	90
WE_27C	12,400	21,600	420	170	170
QW_27C	16,000	22,200	420	200	200
WE_35C	29,800	49,400	1,480	670	670
QW_35C	36,800	49,200	1,510	650	650
WE_50C	61,520	97,000	4,030	1,960	1,960

<sup>1)</sup> Dynamic load rating for 50,000 m travel path

### 3.4.7 Rigidity

The rigidity depends on the preload. With the formula F 3.12, the deformation can be calculated depending on the rigidity.

F 3.12

$$\delta = \frac{P}{k}$$

$\delta$  Deformation [ $\mu\text{m}$ ]  
 $P$  Operating load [N]  
 $k$  Rigidity value [N/ $\mu\text{m}$ ]

Table 3.61 Radial rigidity of WE/QW series

Load type	Series/ Size	Rigidity depending on the preload		
		Z0	ZA	ZB
Heavy load	WE_17C	128	166	189
	WE_21C	154	199	228
	QW_21C	140	176	200
	WE_27C	187	242	276
	QW_27C	183	229	260
	WE_35C	281	364	416
	QW_35C	277	348	395
	WE_50C	428	554	633

Unit: N/ $\mu\text{m}$

# Linear guideways

## WE/QW series

### 3.4.8 Dimensions of the WE/QW blocks

#### 3.4.8.1 WEH/QWH

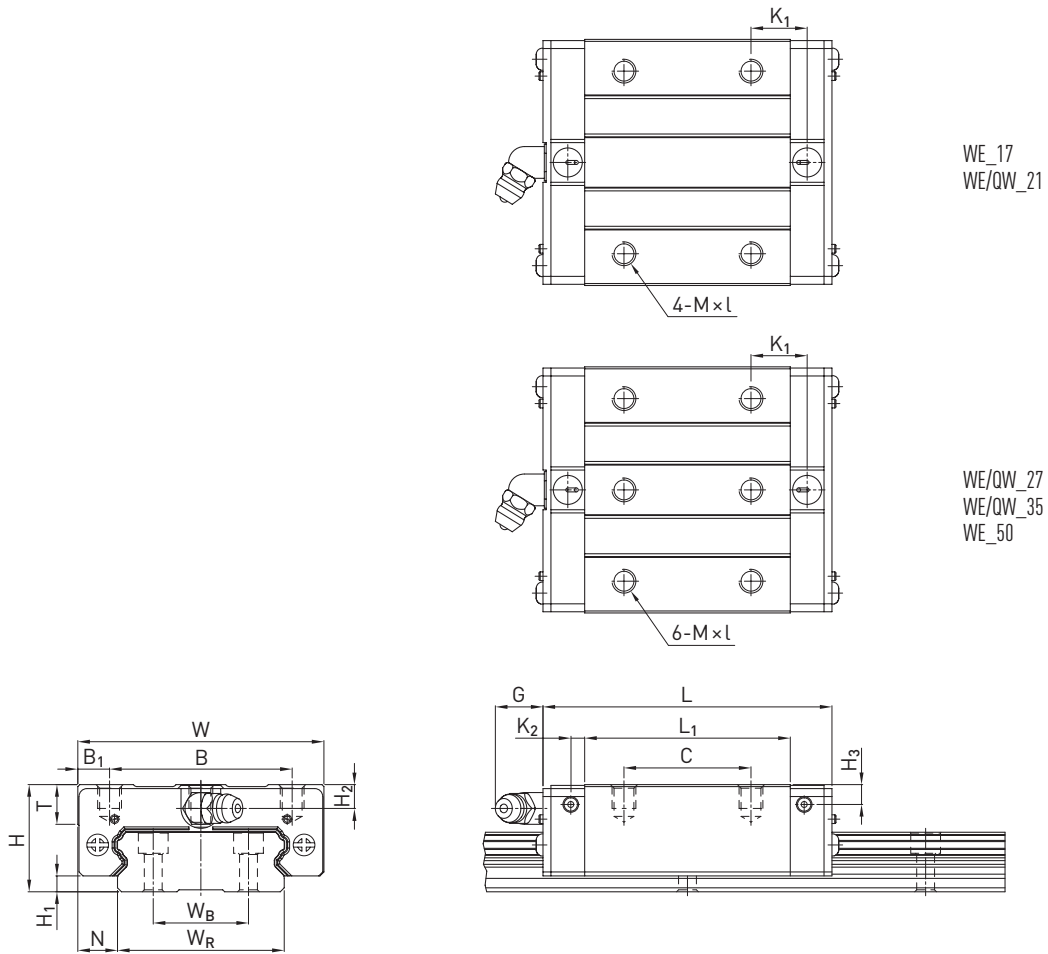

WE\_17  
WE/QW\_21

WE/QW\_27  
WE/QW\_35  
WE\_50

Table 3.62 Dimensions of the block

Series/size	Installation dimensions [mm]			Dimensions of the block [mm]													Load ratings [N]		Weight [kg]
	H	H <sub>1</sub>	N	W	B	B <sub>1</sub>	C	L <sub>1</sub>	L	K <sub>1</sub>	K <sub>2</sub>	G	M × l	T	H <sub>2</sub>	H <sub>3</sub>	C <sub>dyn</sub>	C <sub>0</sub>	
WEH17CA	17	2.5	8.5	50	29	10.5	15	35.0	50.6	—	3.10	4.9	M4 × 5	6.0	4.0	3.0	5,230	9,640	0.12
WEH21CA	21	3.0	8.5	54	31	11.5	19	41.7	59.0	14.68	3.65	12.0	M5 × 6	8.0	4.5	4.2	7,210	13,700	0.20
QWH21CA	21	3.0	8.5	54	31	11.5	19	41.7	59.0	14.68	3.65	12.0	M5 × 6	8.0	4.5	4.2	9,000	12,100	0.20
WEH27CA	27	4.0	10.0	62	46	8.0	32	51.8	72.8	14.15	3.50	12.0	M6 × 6	10.0	6.0	5.0	12,400	21,600	0.35
QWH27CA	27	4.0	10.0	62	46	8.0	32	56.6	73.2	15.45	3.15	12.0	M6 × 6	10.0	6.0	5.0	16,000	22,200	0.35
WEH35CA	35	4.0	15.5	100	76	12.0	50	77.6	102.6	18.35	5.25	12.0	M8 × 8	13.0	8.0	6.5	29,800	49,400	1.10
QWH35CA	35	4.0	15.5	100	76	12.0	50	83.0	107.0	21.50	5.50	12.0	M8 × 8	13.0	8.0	6.5	36,800	49,200	1.10
WEH50CA	50	7.5	20.0	130	100	15.0	65	112.0	140.0	28.05	6.00	12.9	M10 × 15	19.5	12.0	10.5	61,520	97,000	3.16

For dimensions of the rail, see Page 90, for standard as well as optional lubrication adapter, see Page 152.

3.4.8.2 WEW/QWW

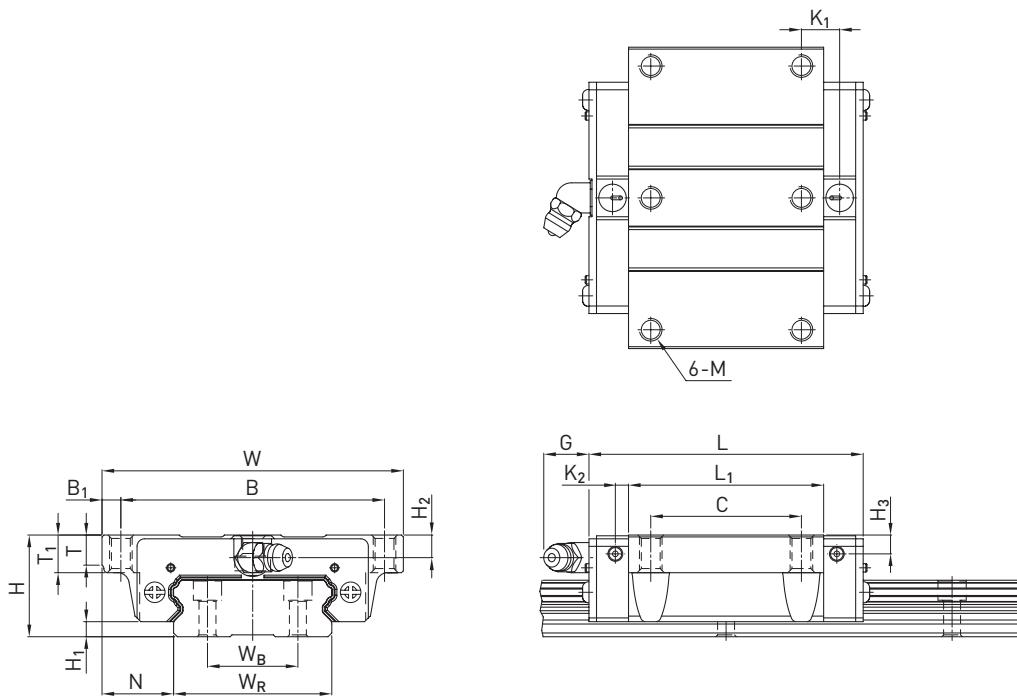

Table 3.63 Dimensions of the block

Series/size	Installation dimensions [mm]			Dimensions of the block [mm]														Load ratings [N]		Weight [kg]
	H	H <sub>1</sub>	N	W	B	B <sub>1</sub>	C	L <sub>1</sub>	L	K <sub>1</sub>	K <sub>2</sub>	G	M	T	T <sub>1</sub>	H <sub>2</sub>	H <sub>3</sub>	C <sub>dyn</sub>	C <sub>0</sub>	
WEW17CC	17	2.5	13.5	60	53	3.5	26	35.0	50.6	—	3.10	4.9	M4	5.3	6	4.0	3.0	5,230	9,640	0.13
WEW21CC	21	3.0	15.5	68	60	4.0	29	41.7	59.0	9.68	3.65	12.0	M5	7.3	8	4.5	4.2	7,210	13,700	0.23
QWW21CC	21	3.0	15.5	68	60	4.0	29	41.7	59.0	9.68	3.65	12.0	M5	7.3	8	4.5	4.2	9,000	12,100	0.23
WEW27CC	27	4.0	19.0	80	70	5.0	40	51.8	72.8	10.15	3.50	12.0	M6	8.0	10	6.0	5.0	12,400	21,600	0.43
QWW27CC	27	4.0	19.0	80	70	5.0	40	56.6	73.2	15.45	3.15	12.0	M6	8.0	10	6.0	5.0	16,000	22,200	0.43
WEW35CC	35	4.0	25.5	120	107	6.5	60	77.6	102.6	13.35	5.25	12.0	M8	11.2	14	8.0	6.5	29,800	49,400	1.26
QWW35CC	35	4.0	25.5	120	107	6.5	60	83.0	107.0	21.50	5.50	12.0	M8	11.2	14	8.0	6.5	36,800	49,200	1.26
WEW50CC	50	7.5	36.0	162	144	9.0	80	112.0	140.0	20.55	6.00	12.9	M10	14.0	18	12.0	10.5	61,520	97,000	3.71

For dimensions of the rail, see Page 90, for standard as well as optional lubrication adapter, see Page 152.

# Linear guideways

## WE/QW series

### 3.4.9 Dimensions of WE profile rails

#### 3.4.9.1 Dimensions WER\_R

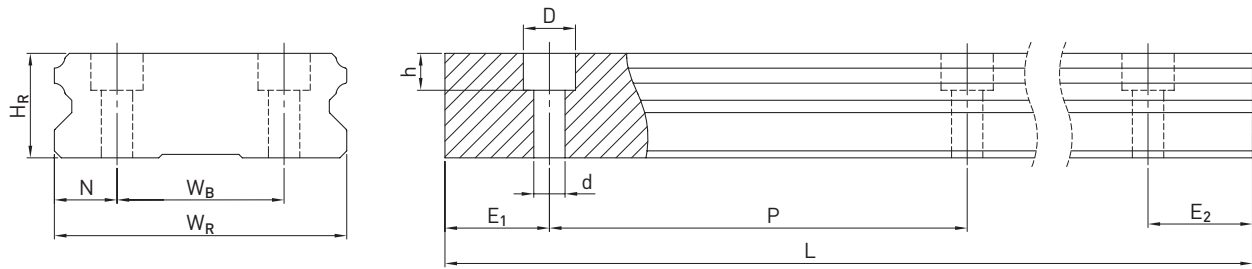

Table 3.64 Dimensions of profile rail WER\_R

Series/size	Assembly screw for rail [mm]	Dimensions of the rail [mm]							Max. length [mm]	Max. length $E_1 = E_2$ [mm]	Min. length [mm]	$E_{1/2}$ min [mm]	$E_{1/2}$ max [mm]	Weight [kg/m]
		$W_R$	$W_B$	$H_R$	$D$	$h$	$d$	$P$						
WER17R	M4 × 12	33	18	9.3	7.5	5.3	4.5	40	4,000	3,960	52	6	34	2.2
WER21R	M4 × 16	37	22	11.0	7.5	5.3	4.5	50	4,000	3,950	62	6	44	3.0
WER27R	M4 × 20	42	24	15.0	7.5	5.3	4.5	60	4,000	3,900	72	6	54	4.7
WER35R	M6 × 25	69	40	19.0	11.0	9.0	7.0	80	4,000	3,920	96	8	72	9.7
WER50R	M8 × 30	90	60	24.0	14.0	12.0	9.0	80	4,000	3,920	98	9	71	14.6

#### 3.4.9.2 Dimensions WER\_T

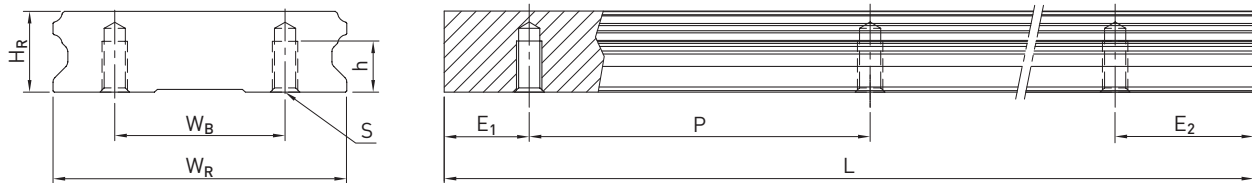

Table 3.65 Dimensions of profile rail WER\_T

Series/size	Dimensions of the rail [mm]						Max. length [mm]	Max. length $E_1 = E_2$ [mm]	Min. length [mm]	$E_{1/2}$ min [mm]	$E_{1/2}$ max [mm]	Weight [kg/m]
	$W_R$	$W_B$	$H_R$	$S$	$h$	$P$						
WER21T	37	22	11	M4	7.0	50	4,000	3,950	62	6	44	3.0
WER27T	42	24	15	M5	7.5	60	4,000	3,900	72	6	54	4.7
WER35T	69	40	19	M6	12.0	80	4,000	3,920	96	8	72	9.7

Note:

1. The tolerance for  $E$  is +0,5 to -1 mm for standard, for joint connections 0 to -0.3 mm.
2. If no information is provided on the  $E_{1/2}$  dimensions, the maximum number of mounting holes is determined taking into account  $E_{1/2}$  min.
3. The rails are shortened to the desired length. If no information on the  $E_{1/2}$  dimensions is provided, then the rails are manufactured symmetrically.

### 3.4.9.3 Calculation of the length of profile rails

HIWIN offers profile rails in customised lengths. To make sure the end of the profile rail does not become unstable, the value E should not exceed half the distance between the mounting holes (P). At the same time, the value  $E_{1/2}$  should be between  $E_{1/2 \text{ min}}$  and  $E_{1/2 \text{ max}}$  so that the mounting hole does not break out.

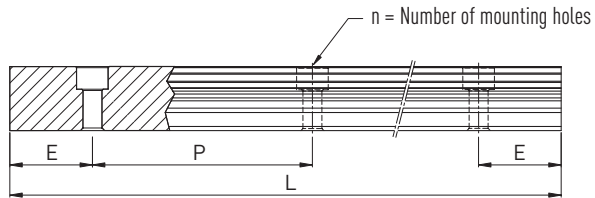

F 3.13

$$L = (n - 1) \times P + E_1 + E_2$$

- L Total length of the profile rail [mm]
- n Number of mounting holes
- P Distance between two mounting holes [mm]
- $E_{1/2}$  Distance from the centre of the last mounting hole to the end of the profile rail [mm].

### 3.4.9.4 Cover caps for mounting holes of profile rails

The cover caps are used to keep the mounting holes free of chips and dirt. The standard plastic cover caps accompany each profile rail. Optional cover caps have to be ordered separately.

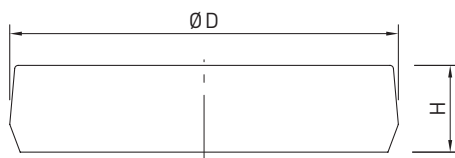

Table 3.66 Cover caps for mounting holes of profile rails

Rail	Screw	Article number			Ø D [mm]	Height H [mm]
		Plastic (200 units)	Brass <sup>1)</sup>	Steel <sup>1)</sup>		
WER17R	M4	5-002218	5-001344	—	7.5	1.2
WER21R	M4	5-002218	5-001344	—	7.5	1.2
WER27R	M4	5-002218	5-001344	—	7.5	1.2
WER35R	M6	5-002221	5-001355	5-001357	11.0	2.8
WER50R	M8	5-002222	5-001360	5-001362	14.0	3.5

<sup>1)</sup> Not recommended for coated rails.

# Linear guideways

## WE/QW series

### 3.4.10 Sealing systems

Different sealing systems are available for HIWIN blocks. You can find an overview on Page 24. The following table shows the total length of the blocks with different sealing systems. Appropriate sealing systems are available for these sizes.

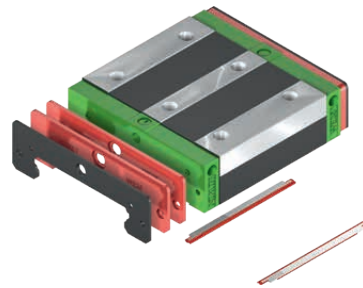

Table 3.67 Total length of block with different sealing systems

Series/size	Total length L (including screws)			
	SS	DD	ZZ	KK
WE_17C	50.6	53.8	52.6	55.8
WE/QW_21C	59.0	63.0	61.0	65.0
WE/QW_27C	72.8	76.8	74.8	78.8
WE/QW_35C	102.6	106.6	105.6	109.6
WE_50C	140.0	145.0	142.0	147.0

Unit: mm

#### 3.4.10.1 Designation of the seal sets

The seal sets are always shipped complete with the installation materials and include the supplemental parts for the standard seal.

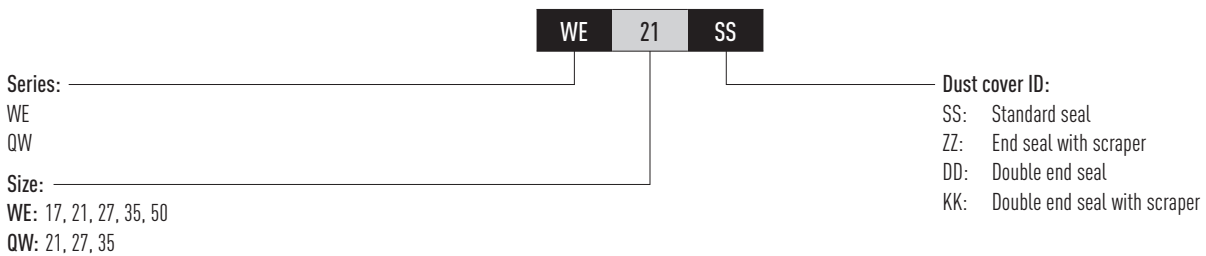

**3.4.11 Tolerances depending on the accuracy class**

The WE and QW series are available in five accuracy classes according to the parallelism between block and rail, height accuracy H and width accuracy N. The selection of the accuracy class is determined by the requirements of the machine.

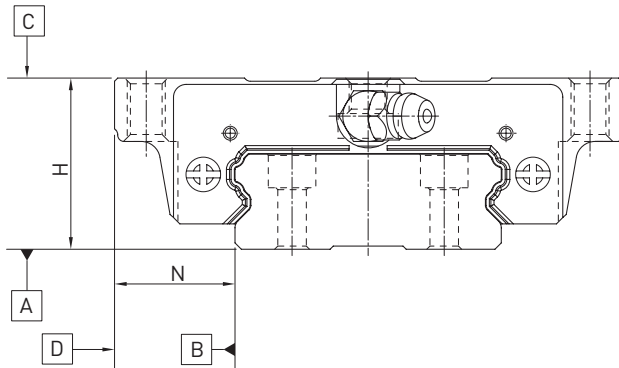

**3.4.11.1 Parallelism**

Parallelism of locating surfaces D and B of the block and rail and of top block surface C to mounting surface A of the rail. Ideal installation of the linear guideway and the measurement in the centre of the block are prerequisites.

Table 3.68 Tolerance of parallelism between block and profile rail

Rail length [mm]	Accuracy class				
	C	H	P	SP	UP
- 100	12	7	3	2	2
100 – 200	14	9	4	2	2
200 – 300	15	10	5	3	2
300 – 500	17	12	6	3	2
500 – 700	20	13	7	4	2
700 – 900	22	15	8	5	3
900 – 1100	24	16	9	6	3
1100 – 1500	26	18	11	7	4
1500 – 1900	28	20	13	8	4
1900 – 2500	31	22	15	10	5
2500 – 3100	33	25	18	11	6
3100 – 3600	36	27	20	14	7
3600 – 4000	37	28	21	15	7

Unit: µm

# Linear guideways

## WE/QW series

### 3.4.11.2 Accuracy – height and width

#### Height tolerance of H

Permissible absolute dimension deviation of height H, measured between the centre of bolting surface C and rail underside A, with any position of the block on the rail.

#### Height variance of H

Permissible deviation of height H between several blocks on one rail, measured at the same position of the rail.

#### Width tolerance of N

Permissible absolute dimension deviation of width N, measured between the centre of bolting surfaces D and B, with any position of the block on the rail.

#### Width variance of N

Permissible deviation of width N between several blocks on one rail, measured at the same position of the rail.

Table 3.69 Tolerances of width and height

Series/size	Accuracy class	Height tolerance of H	Width tolerance of N	Height variance of H	Width variance of N
WE_17, 21 QW_21	C (Normal)	$\pm 0.1$	$\pm 0.1$	0.02	0.02
	H (high)	$\pm 0.03$	$\pm 0.03$	0.01	0.01
	P (precision)	$0/-0.03^{1)}$ $\pm 0.015^{2)}$	$0/-0.03^{1)}$ $\pm 0.015^{2)}$	0.006	0.006
	SP (super precision)	$0/-0.015$	$0/-0.015$	0.004	0.004
	UP (ultra precision)	$0/-0.008$	$0/-0.008$	0.003	0.003
WE_27, 35 QW_27, 35	C (Normal)	$\pm 0.1$	$\pm 0.1$	0.02	0.03
	H (high)	$\pm 0.04$	$\pm 0.04$	0.015	0.015
	P (precision)	$0/-0.04^{1)}$ $\pm 0.02^{2)}$	$0/-0.04^{1)}$ $\pm 0.02^{2)}$	0.007	0.007
	SP (super precision)	$0/-0.02$	$0/-0.02$	0.005	0.005
	UP (ultra precision)	$0/-0.01$	$0/-0.01$	0.003	0.003
WE_50	C (Normal)	$\pm 0.1$	$\pm 0.1$	0.03	0.03
	H (high)	$\pm 0.05$	$\pm 0.05$	0.02	0.02
	P (precision)	$0/-0.05^{1)}$ $\pm 0.025^{2)}$	$0/-0.05^{1)}$ $\pm 0.025^{2)}$	0.01	0.01
	SP (super precision)	$0/-0.03$	$0/-0.03$	0.01	0.01
	UP (ultra precision)	$0/-0.02$	$0/-0.02$	0.01	0.01

Unit: mm

<sup>1)</sup> Assembled linear guideway

<sup>2)</sup> Unassembled linear guideway

### 3.4.11.3 Permissible tolerances of the mounting surface

Once the requirements for the accuracy of the mounting surfaces are met, the high accuracy, rigidity and service life of the WE and QW series linear guideways are achieved.

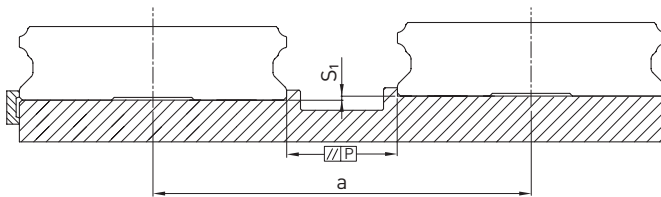

### Tolerance of parallelism of reference surface (P):

Table 3.70 Maximum tolerance for parallelism (P)

Series/Size	Preload class		
	Z0	ZA	ZB
WE_17	20	15	9
WE/QW_21	25	18	9
WE/QW_27	25	20	13
WE/QW_35	30	22	20
WE_50	40	30	27

Unit:  $\mu\text{m}$

### Tolerance of height of reference surface (S<sub>1</sub>):

F 3.14  $S_1 = a \times K$

S<sub>1</sub> Maximum height tolerance [mm]

a Distance between rails [mm]

K Coefficient of height tolerance

Table 3.71 Coefficient of height tolerance (K)

Series/Size	Preload class		
	Z0	ZA	ZB
WE_17	$1.3 \times 10^{-4}$	$0.4 \times 10^{-4}$	—
WE/QW_21	$2.6 \times 10^{-4}$	$1.7 \times 10^{-4}$	$0.9 \times 10^{-4}$
WE/QW_27	$2.6 \times 10^{-4}$	$1.7 \times 10^{-4}$	$0.9 \times 10^{-4}$
WE/QW_35	$2.6 \times 10^{-4}$	$1.7 \times 10^{-4}$	$1.4 \times 10^{-4}$
WE_50	$3.4 \times 10^{-4}$	$2.2 \times 10^{-4}$	$1.8 \times 10^{-4}$

### 3.4.12 Shoulder heights and edge roundings

Inaccurate shoulder heights and edge roundings of mounting surfaces impair accuracy and may conflict with the block or rail profile. The following shoulder heights and edge profiles must be observed to avoid assembly problems.

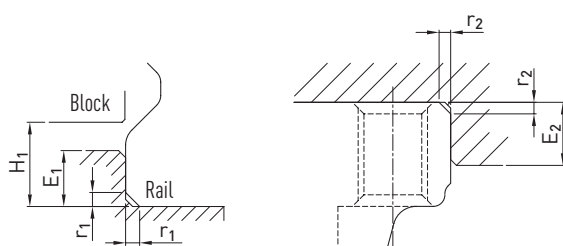

Table 3.72 Shoulder heights and edge roundings

Series/Size	Max. radius of edges r <sub>1</sub>	Max. radius of edges r <sub>2</sub>	Shoulder height of the reference edge of rail E <sub>1</sub>	Shoulder height of the reference edge of block E <sub>2</sub>	Clearance height under block H <sub>1</sub>
WE_17	0.4	0.4	2.0	4.0	2.5
WE/QW_21	0.4	0.4	2.5	5.0	3.0
WE/QW_27	0.5	0.5	3.0	7.0	4.0
WE/QW_35	0.5	0.5	3.5	10.0	4.0
WE_50	0.8	0.8	6.0	10.0	7.5

Unit: mm

# Linear guideways

## RG/QR series

---

### 3.5 RG/QR series

#### 3.5.1 Properties of the RG and QR series linear guideways

The HIWIN linear guideways of the RG series use rollers rather than balls as rolling elements. The RG series offers extremely high rigidity and a very high load capacity. It is designed with a 45° contact angle. The linear contact surface dramatically reduces deformation caused by loading, thereby achieving extremely high rigidity and load capacity in all 4 load directions. The linear guideways of the RG series are thus ideally suited for use in high-precision manufacturing.

The models of the QR series with SynchMotion™ technology offer all the advantages of the standard RG series. Controlled movement of the rollers at a defined distance also results in improved synchronous performance, higher reliable travel speeds, extended lubrication intervals and less running noise. Since the installation dimensions of the QR blocks are identical to those of the RG blocks, they are also mounted on the RGR standard rail and can thus be easily interchanged. For further information, see Page 26.

#### 3.5.2 Layout of RG/QR series

- Four-row recirculating roller guide
- 45° contact angle
- Different sealing variants, depending on application area
- 6 connection options for lubricating nipples and lubrication adapters
- SynchMotion™ technology (QR series)

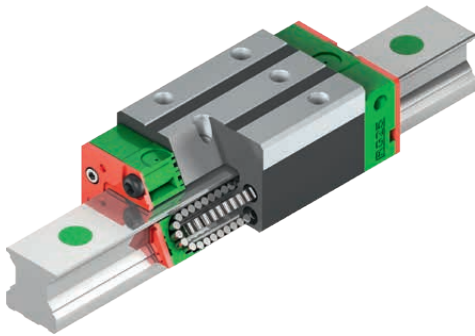

Layout of RG series

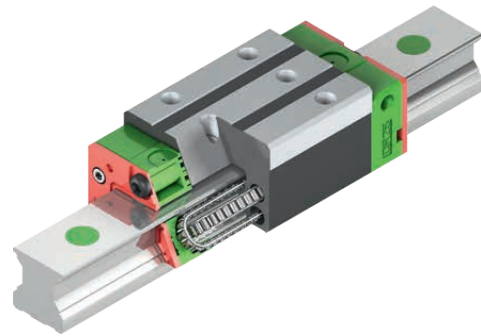

Layout of QR series

#### Advantages:

- Backlash-free
- Exchangeable
- Very high load ratings
- Very high rigidity
- Low displacement forces even with high preload

#### Additional advantages of QR series:

- Improved synchronous performance
- Optimised for higher travel speeds
- Extended relubrication intervals
- Reduced running noise
- Higher dynamic load rating

#### 3.5.3 Order codes of RG/QR series

For RG/QR linear guideways, there is a distinction made between assembled and non-assembled models. The dimensions of both models are the same. The main difference is that, in the unassembled models, blocks and profile rails can be freely interchanged. The article numbers of the series contain the dimensions, the model, the accuracy class, the preload, etc.

## Order code for linear guideway (assembled)

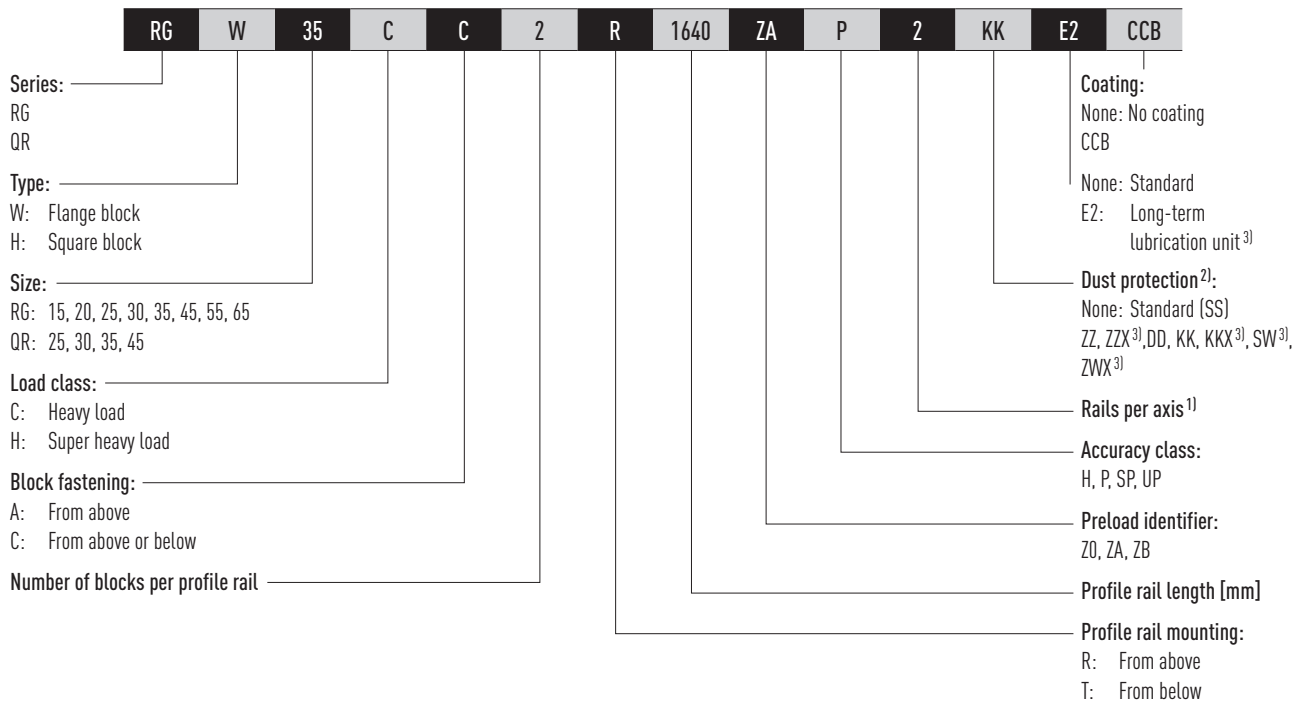

## Order number of block (not assembled)

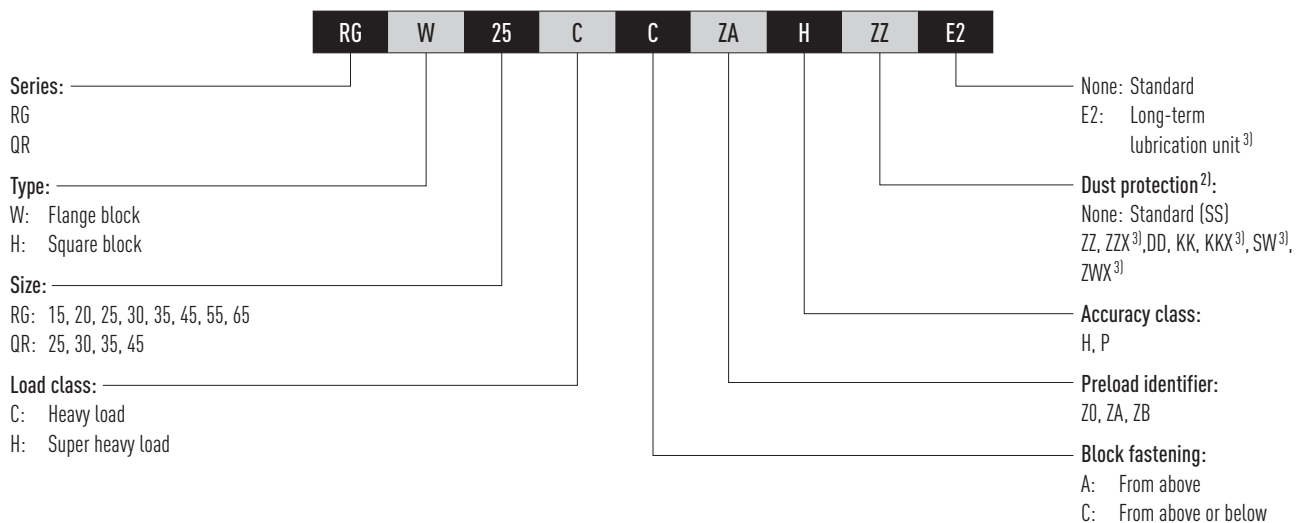

## Order number of profile rail (not assembled)

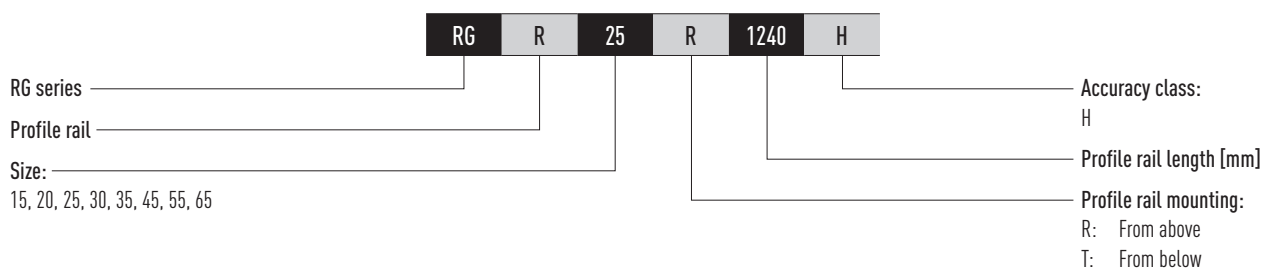

### Note:

<sup>1)</sup> The number 2 is also a quantity indication, i.e. one piece of the article described above consists of one pair of rails.

No number is given for single profile rails. In the case of multi-part rails, the joint is offset as standard.

<sup>2)</sup> An overview of the individual sealing systems can be found on Page 24

<sup>3)</sup> Only available for RG

# Linear guideways

RG/QR series

## 3.5.4 Block types

HIWIN offers block and flange blocks for its linear guideways. Due to the low installation height and the larger mounting surface, flange blocks are better suited for large loads.

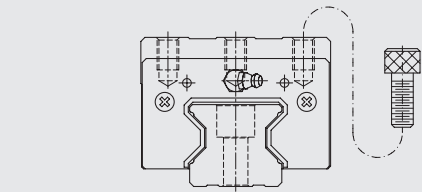
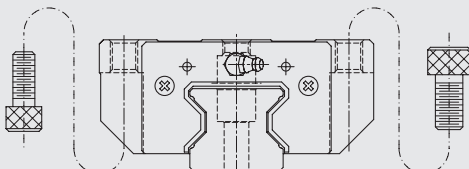
Type	Series/size	Layout	Height [mm]	Typical applications
<b>Square type</b>	RGH-CA RGH-HA		28 - 90	<ul style="list-style-type: none"> <li>- Automation technology</li> <li>- Transport technology</li> <li>- CNC machining centres</li> <li>- High performance cutting machines</li> <li>- CNC grinding machines</li> <li>- Injection moulding machines</li> <li>- Portal milling machines</li> </ul>
<b>Flange type</b>	RGW-CC RGW-HC		24 - 90	<ul style="list-style-type: none"> <li>- Machines and systems with high required rigidity</li> <li>- Machines and systems with high required load ratings</li> <li>- Spark erosion machines</li> </ul>

## 3.5.5 Profile rail types

In addition to profile rails with standard fastening from above, HIWIN also offers rails for fastening from below.

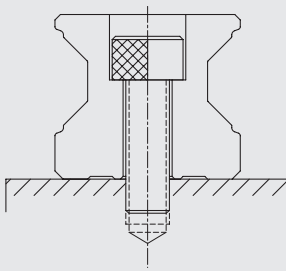
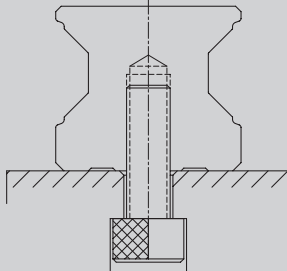
Fastening from above	Fastening from below
	
RGR_R	RGR_T

### 3.5.6 Preload

#### Definition

Each linear guideway can be preloaded via the ball size. The curve shows that the rigidity doubles at high preload. The RG/QR series of linear guideways offers three standard preloads for different applications and conditions.

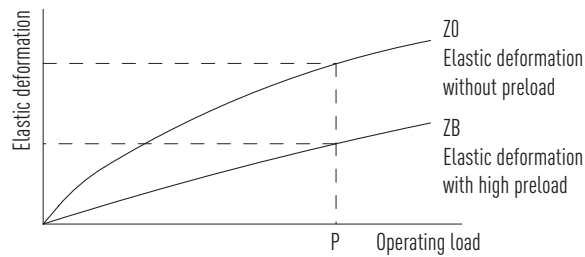

#### Preload identifier

Identifier	Preload		Application
Z0	Slight preload	0.02 – 0.04 $C_{dyn}$	Constant load direction, low jolting and low required accuracy
ZA	Medium preload	0.07 – 0.09 $C_{dyn}$	High precision required
ZB	High preload	0.12 – 0.14 $C_{dyn}$	Very high rigidity and precision required, vibration and jolting

The figure shows the relationship between rigidity, frictional resistance and nominal service life. For smaller size models, preload is not recommended above ZA to avoid preload-related reductions in service life.

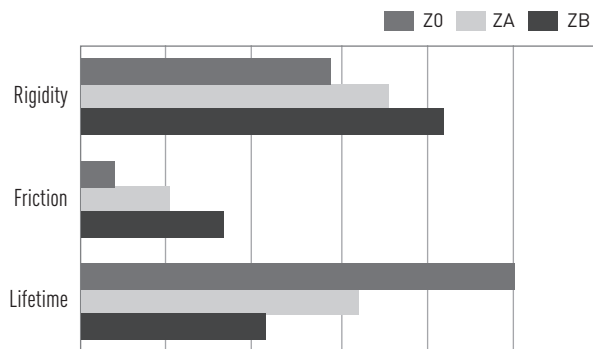

# Linear guideways

## RG/QR series

### 3.5.7 Load ratings and torques

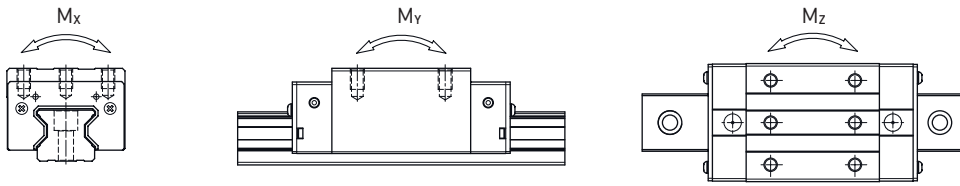

Table 3.76 Load ratings and torques for RG/QR series

Series/Size	Dynamic load rating $C_{dyn}$ [N] <sup>1)</sup>	Static load rating $C_0$ [N]	Static moment [Nm]		
			$M_{0x}$	$M_{0y}$	$M_{0z}$
RG_15C	11,300	24,000	311	173	173
RG_20C	21,300	46,700	647	460	460
RG_20H	26,900	63,000	872	837	837
RG_25C	27,700	57,100	758	605	605
QR_25C	38,500	54,400	722	627	627
RG_25H	33,900	73,400	975	991	991
QR_25H	44,700	65,300	867	907	907
RG_30C	39,100	82,100	1,445	1,060	1,060
QR_30C	51,500	73,000	1,284	945	945
RG_30H	48,100	105,000	1,846	1,712	1,712
QR_30H	64,700	95,800	1,685	1,630	1,630
RG_35C	57,900	105,200	2,170	1,440	1,440
QR_35C	77,000	94,700	1,955	1,331	1,331
RG_35H	73,100	142,000	2,930	2,600	2,600
QR_35H	95,700	126,300	2,606	2,335	2,335
RG_45C	92,600	178,800	4,520	3,050	3,050
QR_45C	123,200	156,400	3,959	2,666	2,666
RG_45H	116,000	230,900	6,330	5,470	5,470
QR_45H	150,800	208,600	5,278	4,694	4,694
RG_55C	130,500	252,000	8,010	5,400	5,400
RG_55H	167,800	348,000	11,150	10,250	10,250
RG_65C	213,000	411,600	16,200	11,590	11,590
RG_65H	275,300	572,700	22,550	22,170	22,170

<sup>1)</sup> Dynamic load rating for 100,000 m travel path

### 3.5.8 Rigidity

The rigidity depends on the preload. With the formula F 3.15, the deformation can be calculated depending on the rigidity.

F 3.15

$$\delta = \frac{P}{k}$$

$\delta$  Deformation [ $\mu\text{m}$ ]  
 P Operating load [N]  
 k Rigidity value [N/ $\mu\text{m}$ ]

Table 3.77 Radial rigidity of RG/QR series

Load type	Series/ Size	Rigidity depending on the preload		
		Z0	ZA	ZB
Heavy load	RG_15C	482	504	520
	RG_20C	586	614	633
	RG_25C	682	717	740
	QR_25C	616	645	665
	RG_30C	809	849	876
	QR_30C	694	726	748
	RG_35C	954	1,002	1,035
	QR_35C	817	856	882
	RG_45C	1,433	1,505	1,554
	QR_45C	1,250	1,310	1,350
	RG_55C	1,515	1,591	1,643
	RG_65C	2,120	2,227	2,300
Super heavy load	RG_20H	786	823	848
	RG_25H	873	917	947
	QR_25H	730	770	790
	RG_30H	1,083	1,136	1,173
	QR_30H	910	950	980
	RG_35H	1,280	1,344	1,388
	QR_35H	1,090	1,140	1,170
	RG_45H	1,845	1,938	2,002
	QR_45H	1,590	1,660	1,720
	RG_55H	2,079	2,182	2,254
	RG_65H	2,931	3,077	3,178

Unit: N/ $\mu\text{m}$

# Linear guideways

RG/QR series

## 3.5.9 Dimensions of the RG/QR blocks

### 3.5.9.1 RGH/QRH

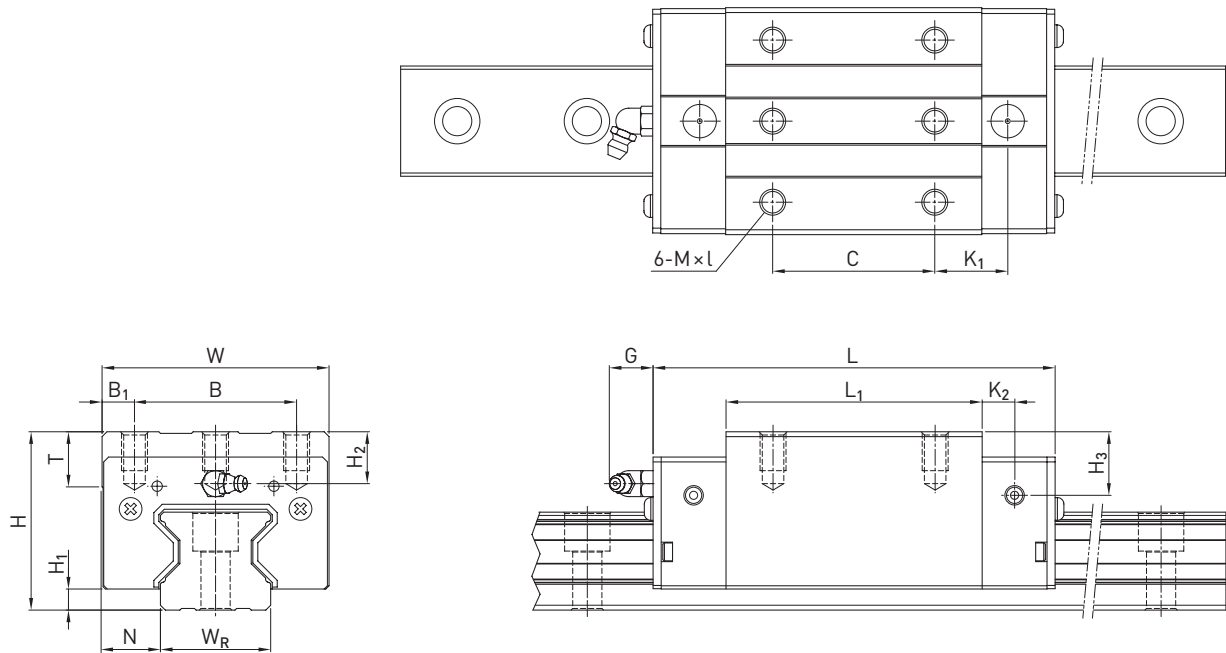

Table 3.78 Dimensions of the block

Series/size	Installation dimensions [mm]			Dimensions of the block [mm]													Load ratings [N]		Weight [kg]
	H	H <sub>1</sub>	N	W	B	B <sub>1</sub>	C	L <sub>1</sub>	L	K <sub>1</sub>	K <sub>2</sub>	G	M × l	T	H <sub>2</sub>	H <sub>3</sub>	C <sub>dyn</sub>	C <sub>0</sub>	
RGH15CA	28	4.0	9.5	34	26	4.0	26	45.0	68.0	13.40	4.70	5.3	M4 × 8	6.0	7.6	10.1	11,300	24,000	0.20
RGH20CA	34	5.0	12.0	44	32	6.0	36	57.5	86.0	15.80	6.00	5.3	M5 × 8	8.0	8.3	8.3	21,300	46,700	0.40
RGH20HA							50	77.5	106.0	18.80							26,900	63,000	0.53
RGH25CA	40	5.5	12.5	48	35	6.5	35	64.5	97.9	20.75	7.25	12.0	M6 × 8	9.5	10.2	10.0	27,700	57,100	0.61
RGH25HA							50	81.0	114.4	21.50							33,900	73,400	0.75
QRH25CA	40	5.5	12.5	48	35	6.5	35	66.0	97.9	20.75	7.25	12.0	M6 × 8	9.5	10.2	10.0	38,500	54,400	0.60
QRH25HA							50	81.0	112.9	21.50							44,700	65,300	0.74
RGH30CA	45	6.0	16.0	60	40	10.0	40	71.0	109.8	23.50	8.00	12.0	M8 × 10	9.5	9.5	10.3	39,100	82,100	0.90
RGH30HA							60	93.0	131.8	24.50							48,100	105,000	1.16
QRH30CA	45	6.0	16.0	60	40	10.0	40	71.0	109.8	23.50	8.00	12.0	M8 × 10	9.5	9.5	10.3	51,500	73,000	0.89
QRH30HA							60	93.0	131.8	24.50							64,700	95,800	1.15
RGH35CA	55	6.5	18.0	70	50	10.0	50	79.0	124.0	22.50	10.00	12.0	M8 × 12	12.0	16.0	19.6	57,900	105,200	1.57
RGH35HA							72	106.5	151.5	25.25							73,100	142,000	2.06
QRH35CA	55	6.5	18.0	70	50	10.0	50	79.0	124.0	22.50	10.00	12.0	M8 × 12	12.0	16.0	19.6	77,000	94,700	1.56
QRH35HA							72	106.5	151.5	25.25							95,700	126,300	2.04
RGH45CA	70	8.0	20.5	86	60	13.0	60	106.0	153.2	31.00	10.00	12.9	M10 × 17	16.0	20.0	24.0	92,600	178,800	3.18
RGH45HA							80	139.8	187.0	37.90							116,000	230,900	4.13
QRH45CA	70	8.0	20.5	86	60	13.0	60	106.0	153.2	31.00	10.00	12.9	M10 × 17	16.0	20.0	24.0	123,200	156,400	3.16
QRH45HA							80	139.8	187.0	37.90							150,800	208,600	4.10
RGH55CA	80	10.0	23.5	100	75	12.5	75	125.5	183.7	37.75	12.50	12.9	M12 × 18	17.5	22.0	27.5	130,500	252,000	4.89
RGH55HA							95	173.8	232.0	51.90							167,800	348,000	6.68
RGH65CA	90	12.0	31.5	126	76	25.0	70	160.0	232.0	60.80	15.80	12.9	M16 × 20	25.0	15.0	15.0	213,000	411,600	8.89
RGH65HA							120	223.0	295.0	67.30							275,300	572,700	12.13

For dimensions of the rail, see Page 104, for standard as well as optional lubrication adapter, see Page 152.

3.5.9.2 RGW/QRW

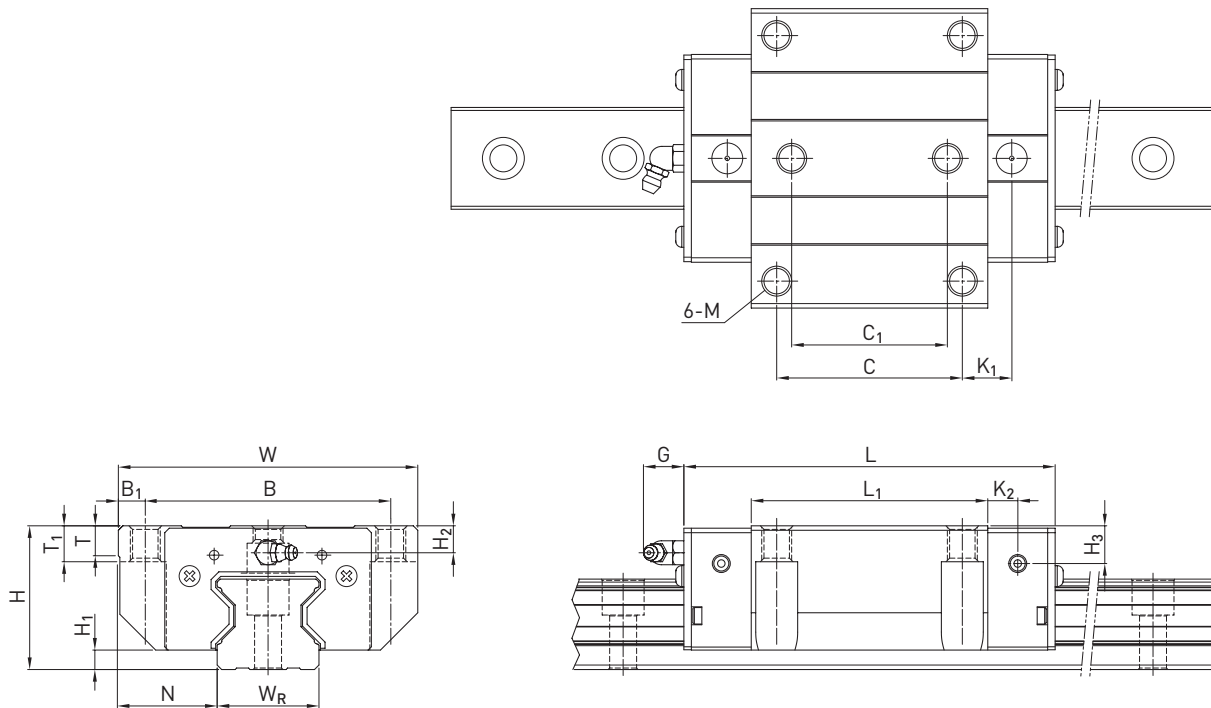

Table 3.79 Dimensions of the block

Series/size	Installation dimensions [mm]			Dimensions of the block [mm]															Load ratings [N]		Weight [kg]
	H	H <sub>1</sub>	N	W	B	B <sub>1</sub>	C	C <sub>1</sub>	L <sub>1</sub>	L	K <sub>1</sub>	K <sub>2</sub>	G	M	T	T <sub>1</sub>	H <sub>2</sub>	H <sub>3</sub>	C <sub>dyn</sub>	C <sub>0</sub>	
RGW15CC	24	4.0	16.0	47	38	4.5	30	26	45.0	68.0	11.40	4.70	5.3	M5	6.0	7	3.6	6.1	11,300	24,000	0.22
RGW20CC	30	5.0	21.5	63	53	5.0	40	35	57.5	86.0	13.80	6.00	5.3	M6	8.0	10	4.3	4.3	21,300	46,700	0.47
RGW20HC									77.5	106.0	23.80	26,900	63,000						0.63		
RGW25CC	36	5.5	23.5	70	57	6.5	45	40	64.5	97.9	15.75	7.25	12.0	M8	9.5	10	6.2	6.0	27,700	57,100	0.72
RGW25HC									81.0	114.4	24.00	33,900	73,400						0.91		
QRW25CC	36	5.5	23.5	70	57	6.5	45	40	66.0	97.9	15.75	7.25	12.0	M8	9.5	10	6.2	6.0	38,500	54,400	0.71
QRW25HC									81.0	112.9	24.00	44,700	65,300						0.90		
RGW30CC	42	6.0	31.0	90	72	9.0	52	44	71.0	109.8	17.50	8.00	12.0	M10	9.5	10	6.5	7.3	39,100	82,100	1.16
RGW30HC									93.0	131.8	28.50	48,100	105,000						1.52		
QRW30CC	42	6.0	31.0	90	72	9.0	52	44	71.0	109.8	17.50	8.00	12.0	M10	9.5	10	6.5	7.3	51,500	73,000	1.15
QRW30HC									93.0	131.8	28.50	64,700	95,800						1.51		
RGW35CC	48	6.5	33.0	100	82	9.0	62	52	79.0	124.0	16.50	10.00	12.0	M10	12.0	13	9.0	12.6	57,900	105,200	1.75
RGW35HC									106.5	151.5	30.25	73,100	142,000						2.40		
QRW35CC	48	6.5	33.0	100	82	9.0	62	52	79.0	124.0	16.50	10.00	12.0	M10	12.0	13	9.0	12.6	77,000	94,700	1.74
QRW35HC									106.5	151.5	30.25	95,700	126,300						2.38		
RGW45CC	60	8.0	37.5	120	100	10.0	80	60	106.0	153.2	21.00	10.00	12.9	M12	14.0	15	10.0	14.0	92,600	178,800	3.43
RGW45HC									139.8	187.0	37.90	116,000	230,900						4.57		
QRW45CC	60	8.0	37.5	120	100	10.0	80	60	106.0	153.2	21.00	10.00	12.9	M12	14.0	15	10.0	14.0	123,200	156,400	3.41
QRW45HC									139.8	187.0	37.90	150,800	208,600						4.54		
RGW55CC	70	10.0	43.5	140	116	12.0	95	70	125.5	183.7	27.75	12.50	12.9	M14	16.0	17	12.0	17.5	130,500	252,000	5.43
RGW55HC									173.8	232.0	51.90	167,800	348,000						7.61		
RGW65CC	90	12.0	53.5	170	142	14.0	110	82	160.0	232.0	40.80	15.80	12.9	M16	22.0	23	15.0	15.0	213,000	411,600	11.63
RGW65HC									223.0	295.0	72.30	275,300	572,700						16.58		

For dimensions of the rail, see Page 104, for standard as well as optional lubrication adapter, see Page 152.

# Linear guideways

## RG/QR series

### 3.5.10 Dimensions of the RG rail

The RG profile rail is used for both the RG and QR blocks.

#### 3.5.10.1 Dimensions RGR\_R

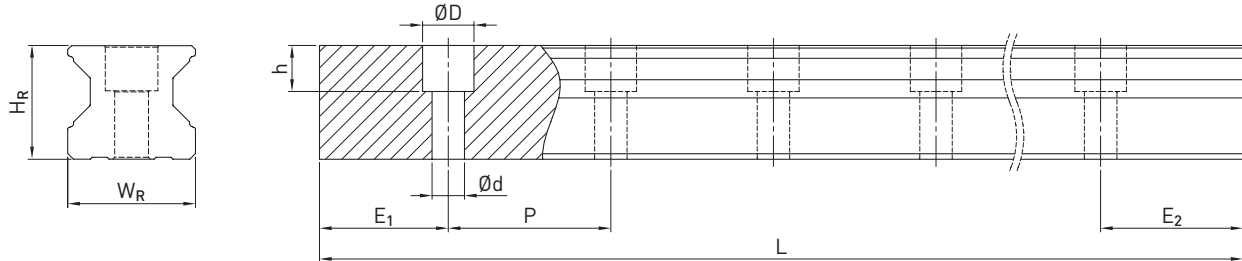

Table 3.80 Dimensions of profile rail RGR\_R

Series/size	Assembly screw for rail [mm]	Dimensions of the rail [mm]						Max. length [mm]	Max. length $E_1 = E_2$ [mm]	Min. length [mm]	$E_{1/2}$ min [mm]	$E_{1/2}$ max [mm]	Weight [kg/m]
		$W_R$	$H_R$	D	h	d	P						
RGR15R	M4 × 20	15	16.5	7.5	5.7	4.5	30.0	4,000	3,960.0	42	6	24.0	1.70
RGR20R	M5 × 25	20	21.0	9.5	8.5	6.0	30.0	4,000	3,960.0	44	7	23.0	2.66
RGR25R	M6 × 30	23	23.6	11.0	9.0	7.0	30.0	4,000	3,960.0	46	8	22.0	3.08
RGR30R	M8 × 35	28	28.0	14.0	12.0	9.0	40.0	4,000	3,920.0	58	9	31.0	4.41
RGR35R	M8 × 35	34	30.2	14.0	12.0	9.0	40.0	4,000/5,600 <sup>1)</sup>	3,920.0/5,520 <sup>1)</sup>	58	9	31.0	6.06
RGR45R	M12 × 45	45	38.0	20.0	17.0	14.0	52.5	4,000/5,600 <sup>1)</sup>	3,937.5/5,437.5 <sup>1)</sup>	76.5	12	40.5	9.97
RGR55R	M14 × 55	53	44.0	23.0	20.0	16.0	60.0	4,000/5,600 <sup>1)</sup>	3,900.0/5,500 <sup>1)</sup>	88	14	46.0	13.98
RGR65R	M16 × 65	63	53.0	26.0	22.0	18.0	75.0	4,000/5,600 <sup>1)</sup>	3,900.0/5,500 <sup>1)</sup>	105	15	60.0	20.22

<sup>1)</sup> Optional type on request

### 3.5.10.2 Dimensions RGR\_T

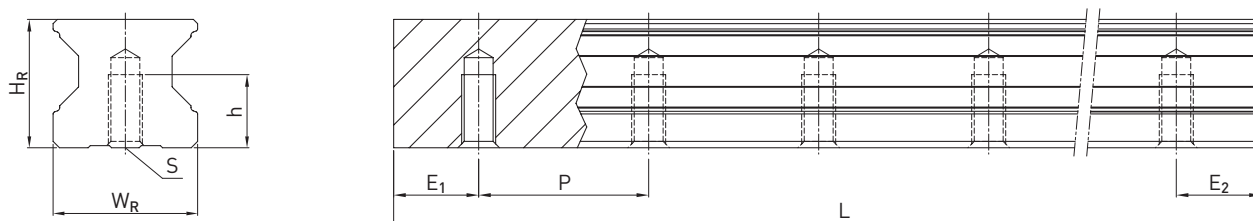

Table 3.81 Dimensions of profile rail RGR\_T

Series/size	Dimensions of the rail [mm]					Max. length [mm]	Max. length $E_1 = E_2$ [mm]	Min. length [mm]	$E_{1/2}$ min [mm]	$E_{1/2}$ max [mm]	Weight [kg/m]
	$W_R$	$H_R$	S	h	P						
RGR15T	15	16.5	M5	8.0	30.0	4,000	3,960.0	42	6	24.0	1.86
RGR20T	20	21.0	M6	10.0	30.0	4,000	3,960.0	44	7	23.0	2.76
RGR25T	23	23.6	M6	12.0	30.0	4,000	3,960.0	46	8	22.0	3.36
RGR30T	28	28.0	M8	15.0	40.0	4,000	3,920.0	58	9	31.0	4.82
RGR35T	34	30.2	M8	17.0	40.0	4,000	3,920.0	58	9	31.0	6.48
RGR45T	45	38.0	M12	24.0	52.5	4,000	3,937.5	76.5	12	40.5	10.83
RGR55T	53	44.0	M14	24.0	60.0	4,000	3,900.0	88	14	46.0	15.15
RGR65T	63	53.0	M20 <sup>1)</sup>	30.0	75.0	4,000	3,900.0	105	15	60.0	21.24

<sup>1)</sup> Deviates from DIN 645

Note:

1. The tolerance for E is +0,5 to -1 mm for standard, for joint connections 0 to -0.3 mm.
2. If no information is provided on the  $E_{1/2}$  dimensions, the maximum number of mounting holes is determined taking into account  $E_{1/2}$  min.
3. The rails are shortened to the desired length. If no information on the  $E_{1/2}$  dimensions is provided, then the rails are manufactured symmetrically.

### 3.5.10.3 Calculation of the length of profile rails

HIWIN offers profile rails in customised lengths. To make sure the end of the profile rail does not become unstable, the value E should not exceed half the distance between the mounting holes (P). At the same time, the value  $E_{1/2}$  should be between  $E_{1/2}$  min and  $E_{1/2}$  max so that the mounting hole does not break out.

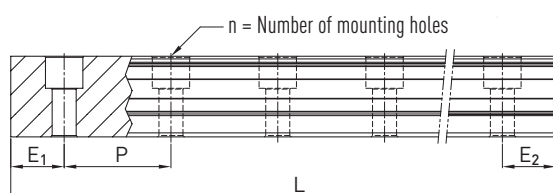

F 3.16

$$L = (n - 1) \times P + E_1 + E_2$$

- L Total length of the profile rail [mm]
- n Number of mounting holes
- P Distance between two mounting holes [mm]
- $E_{1/2}$  Distance from the centre of the last mounting hole to the end of the profile rail [mm].

# Linear guideways

## RG/QR series

### 3.5.10.4 Cover caps for mounting holes of profile rails

The cover caps are used to keep the mounting holes free of chips and dirt. The standard plastic cover caps accompany each profile rail. Optional cover caps have to be ordered separately.

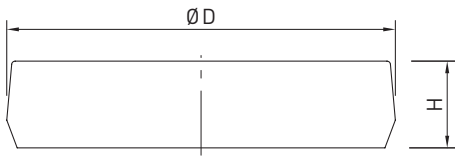

Table 3.82 Cover caps for mounting holes of profile rails

Rail	Screw	Article number			Ø D [mm]	Height H [mm]
		Plastic (200 units)	Brass <sup>1)</sup>	Steel <sup>1)</sup>		
RGR15R	M4	5-002218	5-001344	—	7.5	1.2
RGR20R	M5	5-002220	5-001350	5-001352	9.5	2.5
RGR25R	M6	5-002221	5-001355	5-001357	11.0	2.8
RGR30R	M8	5-002222	5-001360	5-001362	14.0	3.5
RGR35R	M8	5-002222	5-001360	5-001362	14.0	3.5
RGR45R	M12	5-002223	5-001324	5-001327	20.0	4.0
RGR55R	M14	5-002224	5-001330	5-001332	23.0	4.0
RGR65R	M16	5-002225	5-001335	5-001337	26.0	4.0

<sup>1)</sup> Not recommended for coated rails.

### 3.5.11 Sealing systems

Different sealing systems are available for HIWIN blocks. You can find an overview on Page 24. The following table shows the total length of the blocks with different sealing systems. Appropriate sealing systems are available for these sizes.

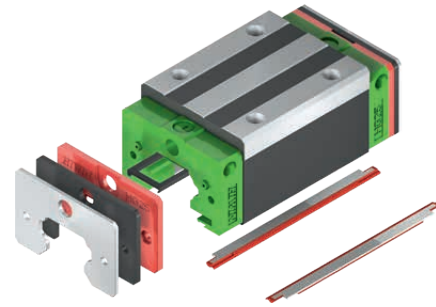

Table 3.83 Total length of block with different sealing systems

Series/size	Total length L (including screws)							
	SS	ZZ	ZZX	DD	KK	KKX	SW	ZWX
RG_15C	68.0	70.0	—	72.4	74.4	—	—	—
RG_20C	86.0	88.0	—	90.4	92.4	—	—	—
RG_20H	106.0	108.0	—	110.4	112.4	—	—	—
RG_25C	97.9	99.9	103.9	102.3	104.3	108.3	—	—
QR_25C	97.7	99.9	—	102.3	104.3	—	—	—
RG_25H	114.4	116.4	120.4	118.8	120.8	124.8	—	—
QR_25H	112.9	114.9	—	117.3	119.3	—	—	—
RG_30C	109.8	112.8	115.8	114.6	117.6	120.6	—	—
QR_30C	109.8	112.8	—	114.6	117.6	—	—	—
RG_30H	131.8	134.8	137.8	136.6	139.6	142.6	—	—
QR_30H	131.8	134.8	—	136.6	139.6	—	—	—
RG_35C	124.0	127.0	130.0	129.0	132.0	135	—	—
QR_35C	124.0	127.0	—	129.0	132.0	—	—	—
RG_35H	151.5	154.5	157.5	156.5	159.5	163.5	—	—
QR_35H	151.5	154.5	—	156.5	159.5	—	—	—
RG_45C	153.2	156.2	159.2	160.4	163.4	166.4	156.5	166.2
QR_45C	153.2	156.2	—	160.4	163.4	—	—	—
RG_45H	187.0	190.0	193.0	194.2	197.2	200.2	190.3	200.0
QR_45H	187.0	190.0	—	194.2	197.2	—	—	—
RG_55C	183.7	186.7	189.7	190.9	193.9	196.9	186.9	198.3
RG_55H	232.0	235.0	238.0	239.2	242.2	245.2	235.2	246.6
RG_65C	232.0	235.0	238.0	240.8	243.8	246.8	235.2	245.3
RG_65H	295.0	298.0	301.0	303.8	306.8	309.8	298.2	308.3

Unit: mm

#### 3.5.11.1 Designation of the seal sets

The seal sets are always shipped complete with the installation materials and include the supplemental parts for the standard seal.

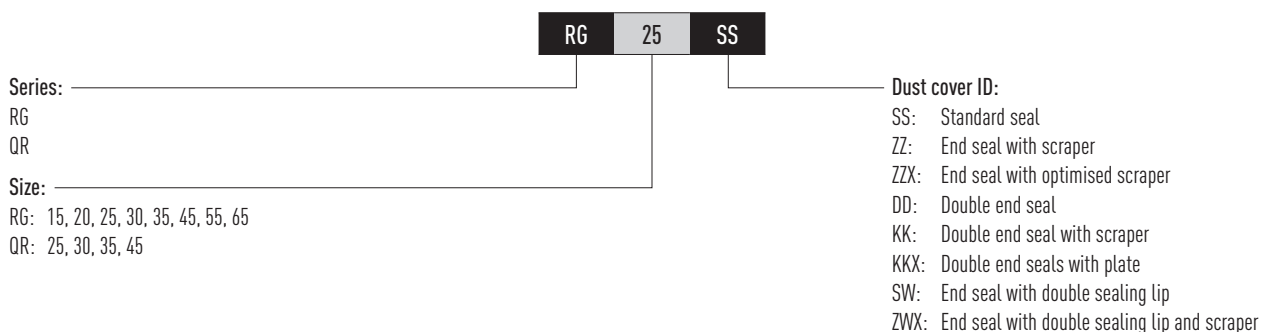

# Linear guideways

## RG/QR series

### 3.5.12 Lubrication unit

Further information on the lubrication unit can be found in the general information

In section "2.6.3 Long-term lubrication unit" on Page 17.

The following drawing shows the dimension (L) for a single-sided lubrication unit. The

dimension for a double-sided lubrication unit results from the dimension  $L + V + T$ . The E2 long-term lubrication unit is available with the sealing systems named in the table.

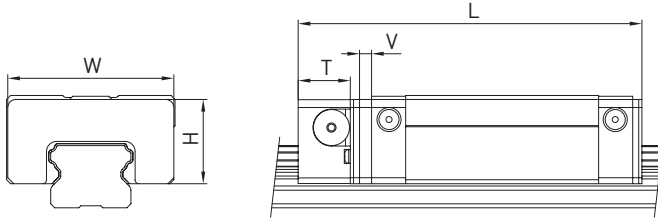

Table 3.84 Dimensions of the block with lubrication unit E2

Model	Dimensions of the block [mm]								Max. running performance <sup>2)</sup> [km] E2 single-sided	Max. running performance <sup>2)</sup> [km] E2 double-sided
	W	H	T	V	L <sub>SS</sub> <sup>1)</sup>	L <sub>ZZ</sub> <sup>1)</sup>	L <sub>DD</sub> <sup>1)</sup>	L <sub>KK</sub> <sup>1)</sup>		
RG_15C	33	19,2	12,5	3,5	84,0	86,0	88,4	90,4	4.000	8.000
RG_20C	43,4	24,2	12,5	3,5	102	104,0	106,4	108,4	4.000	8.000
RG_20H	43,4	24,2	12,5	3,5	122	124,0	126,4	128,4	4.000	8.000
RG_25C	46,8	29,2	13,5	3,5	114,9	116,9	119,3	121,3	4,000	8,000
RG_25H	46,8	29,2	13,5	3,5	131,4	133,4	135,8	137,8	4,000	8,000
RG_30C	58,8	34,9	13,5	3,5	126,8	129,8	131,6	134,6	4,000	8,000
RG_30H	58,8	34,9	13,5	3,5	148,8	151,8	153,6	156,6	4,000	8,000
RG_35C	68,8	40,3	13,5	3,5	141,0	144,0	146,0	149,0	4,000	8,000
RG_35H	68,8	40,3	13,5	3,5	168,5	171,5	173,5	176,5	4,000	8,000
RG_45C	83,8	50,2	16,0	4,5	173,7	176,7	180,9	183,9	4,000	8,000
RG_45H	83,8	50,2	16,0	4,5	207,5	210,5	214,7	217,7	4,000	8,000
RG_55C	97,6	58,4	16,0	4,5	204,2	207,2	211,4	214,4	4,000	8,000
RG_55H	97,6	58,4	16,0	4,5	252,5	255,5	259,7	262,7	4,000	8,000
RG_65C	121,7	76,1	16,0	4,5	252,5	255,5	261,3	264,3	4,000	8,000
RG_65H	121,7	76,1	16,0	4,5	315,5	318,5	324,3	327,3	4,000	8,000

<sup>1)</sup> Total length depending on the selected dust protection. SS = Standard dust protection

<sup>2)</sup> Further details can be found in the assembly instructions in the "Lubrication" chapter

### 3.5.13 Tolerances depending on the accuracy class

The RG and QR series are available in four accuracy classes according to the parallelism between block and rail, height accuracy H and width accuracy N. The selection of the accuracy class is determined by the requirements of the machine.

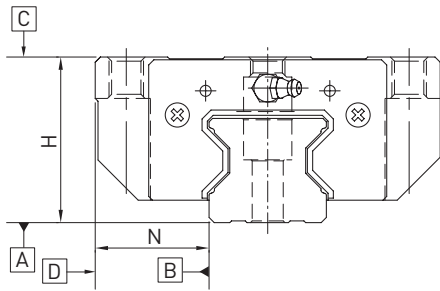

#### 3.5.13.1 Parallelism

Parallelism of locating surfaces D and B of the block and rail and of top block surface C to mounting surface A of the rail. Ideal installation of the linear guideway and the measurement in the centre of the block are prerequisites.

Table 3.85 Tolerance of parallelism between block and profile rail

Rail length [mm]	Accuracy class			
	H	P	SP	UP
– 100	7	3	2	2
100 – 200	9	4	2	2
200 – 300	10	5	3	2
300 – 500	12	6	3	2
500 – 700	13	7	4	2
700 – 900	15	8	5	3
900 – 1100	16	9	6	3
1100 – 1500	18	11	7	4
1500 – 1900	20	13	8	4
1900 – 2500	22	15	10	5
2500 – 3100	25	18	11	6
3100 – 3600	27	20	14	7
3600 – 4000	28	21	15	7

Unit:  $\mu\text{m}$

# Linear guideways

## RG/QR series

### 3.5.13.2 Accuracy – height and width

#### Height tolerance of H

Permissible absolute dimension deviation of height H, measured between the centre of bolting surface C and rail underside A, with any position of the block on the rail.

#### Height variance of H

Permissible deviation of height H between several blocks on one rail, measured at the same position of the rail.

#### Width tolerance of N

Permissible absolute dimension deviation of width N, measured between the centre of bolting surfaces D and B, with any position of the block on the rail.

#### Width variance of N

Permissible deviation of width N between several blocks on one rail, measured at the same position of the rail.

Table 3.86 Tolerances of width and height

Series/size	Accuracy class	Height tolerance of H	Width tolerance of N	Height variance of H	Width variance of N
<b>RG_15, 20</b>	H (high)	± 0.03	± 0.03	0.01	0.01
	P (precision)	0/- 0.03 <sup>1)</sup> ± 0.015 <sup>2)</sup>	0/- 0.03 <sup>1)</sup> ± 0.015 <sup>2)</sup>	0.006	0.006
	SP (super precision)	0/- 0.015	0/- 0.015	0.004	0.004
	UP (ultra precision)	0/- 0.008	0/- 0.008	0.003	0.003
<b>RG_25, 30, 35 QR_25, 30, 35</b>	H (high)	± 0.04	± 0.04	0.015	0.015
	P (precision)	0/- 0.04 <sup>1)</sup> ± 0.02 <sup>2)</sup>	0/- 0.04 <sup>1)</sup> ± 0.02 <sup>2)</sup>	0.007	0.007
	SP (super precision)	0/- 0.02	0/- 0.02	0.005	0.005
	UP (ultra precision)	0/- 0.01	0/- 0.01	0.003	0.003
<b>RG_45, 55 QR_45</b>	H (high)	± 0.05	± 0.05	0.015	0.02
	P (precision)	0/- 0.05 <sup>1)</sup> ± 0.025 <sup>2)</sup>	0/- 0.05 <sup>1)</sup> ± 0.025 <sup>2)</sup>	0.007	0.01
	SP (super precision)	0/- 0.03	0/- 0.03	0.005	0.007
	UP (ultra precision)	0/- 0.02	0/- 0.02	0.003	0.005
<b>RG_65</b>	H (high)	± 0.07	± 0.07	0.02	0.025
	P (precision)	0/- 0.07 <sup>1)</sup> ± 0.035 <sup>2)</sup>	0/- 0.07 <sup>1)</sup> ± 0.035 <sup>2)</sup>	0.01	0.015
	SP (super precision)	0/- 0.05	0/- 0.05	0.007	0.01
	UP (ultra precision)	0/- 0.03	0/- 0.03	0.005	0.007

Unit: mm

<sup>1)</sup> Assembled linear guideway

<sup>2)</sup> Unassembled linear guideway

### 3.5.13.3 Permissible tolerances of the mounting surface

Once the requirements for the accuracy of the mounting surfaces are met, the high accuracy, rigidity and service life of the RG/QR series linear guideways are achieved.

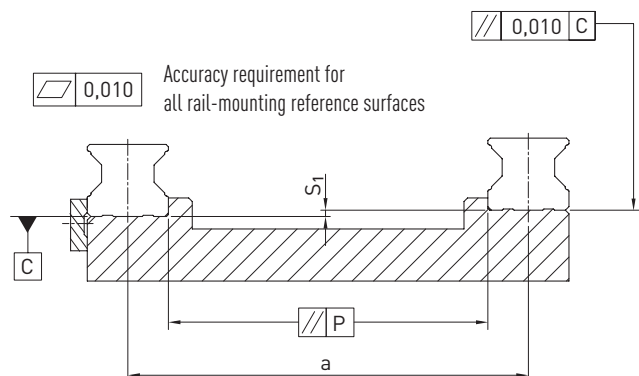

#### Tolerance of parallelism of reference surface (P)

Table 3.87 Maximum tolerance for parallelism (P)

Series/Size	Preload class		
	Z0	ZA	ZB
RG_15	5	3	3
RG_20	8	6	4
RG/QR_25	9	7	5
RG/QR_30	11	8	6
RG/QR_35	14	10	7
RG/QR_45	17	13	9
RG_55	21	14	11
RG_65	27	18	14

Unit:  $\mu\text{m}$

#### Tolerance of height of reference surface ( $S_1$ )

**F 3.17**  $S_1 = a \times K - T_H$

- $S_1$  Maximum height tolerance [mm]
- $a$  Distance between rails [mm]
- $K$  Coefficient of height tolerance
- $T_H$  Tolerance of height according to Table 3.86

Table 3.88 Coefficient of height tolerance (K)

Series/Size	Preload class		
	Z0	ZA	ZB
RG_15 – 65/QR_25 – 45	$2.2 \times 10^{-4}$	$1.7 \times 10^{-4}$	$1.2 \times 10^{-4}$

Note: If  $S_1 < 0$ , select another tolerance class!

# Linear guideways

RG/QR series

## Height tolerance for mounting surface on block

- The height tolerance of the reference surface when two or more blocks are used in parallel ( $S_2$ )

 0.010 Accuracy requirement for all block-mounting reference surfaces

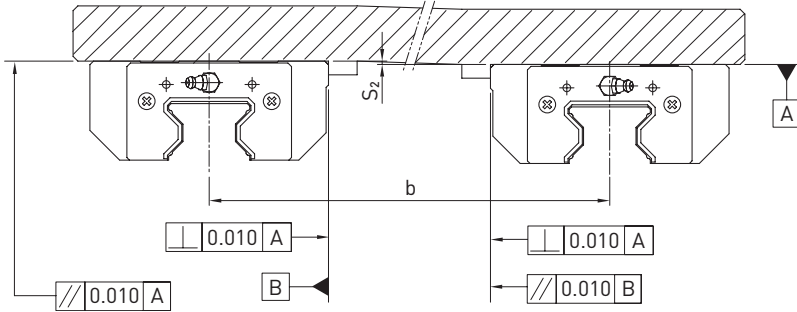

**F 3.18**  $S_2 = b \times 4,2 \times 10^{-5}$

$S_2$  Maximum height tolerance [mm]  
 $b$  Distance between blocks [mm]

- The height tolerance of the reference surface when two or more blocks are used in parallel ( $S_3$ )

 0.010 Accuracy requirement for all block-mounting reference surfaces

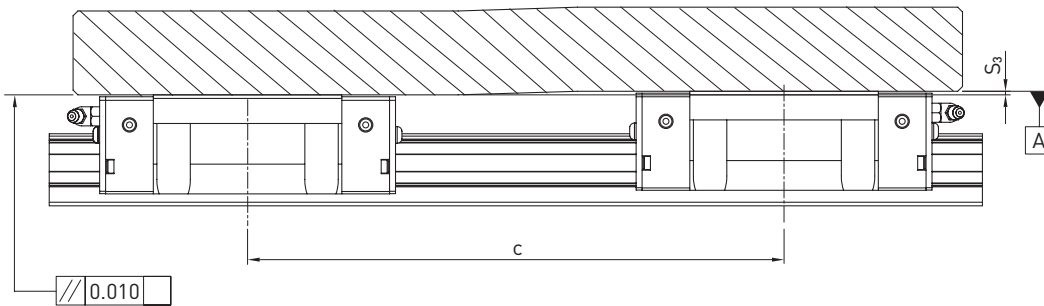

**F 3.19**  $S_3 = c \times 4,2 \times 10^{-5}$

$S_3$  Maximum height tolerance [mm]  
 $c$  Distance between blocks [mm]

**3.5.14 Shoulder heights and edge roundings**

Inaccurate shoulder heights and edge roundings of mounting surfaces impair accuracy and may conflict with the block or rail profile. The following shoulder heights and edge profiles must be observed to avoid assembly problems.

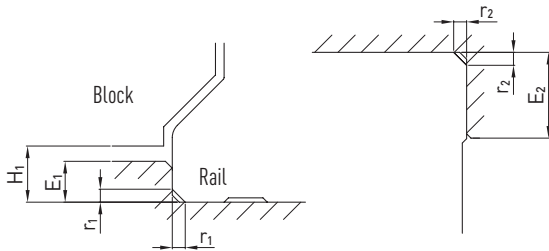

Table 3.89 Shoulder heights and edge roundings

Series/Size	Max. radius of edges $r_1$	Max. radius of edges $r_2$	Shoulder height of the reference edge of rail $E_1$	Shoulder height of the reference edge of block $E_2$	Clearance height under block $H_1$
RG_15	0.5	0.5	3.0	4.0	4.0
RG_20	0.5	0.5	3.5	5.0	5.0
RG/QR_25	1.0	1.0	5.0	5.0	5.5
RG/QR_30	1.0	1.0	5.0	5.0	6.0
RG/QR_35	1.0	1.0	6.0	6.0	6.5
RG/QR_45	1.0	1.0	7.0	8.0	8.0
RG_55	1.5	1.5	9.0	10.0	10.0
RG_65	1.5	1.5	10.0	10.0	12.0

Unit: mm

# Linear guideways

## CRG series

---

### 3.6 CRG series

#### 3.5.15 Properties of the CRG series linear guideways

Roller guides with cover strip for heavy-duty applications with maximum requirements on load ratings and torque capacity. The HIWIN linear guideways of the CRG series use rollers rather than balls as rolling elements. The CRG series offers extremely high rigidity and a very high load capacity. It is designed with a 45° contact angle. The linear contact surface dramatically reduces deformation caused by loading, thereby achieving extremely high rigidity and load capacity in all 4 load directions. The linear guideways of the CRG series are thus ideally suited for use in high-precision manufacturing.

A cover strip is available as an option – dirt ingress and wear of the sealing lip are thus permanently reduced to a minimum. Thanks to the mounting aid, the cover strip can be installed in just a few steps.

#### 3.5.16 Layout of CRG series

- Backlash-free, four-row recirculating roller guide with optimum dust protection even in the standard version.
- Easy installation, better protection against dirt ingress and wear of the end seals with cover strip.

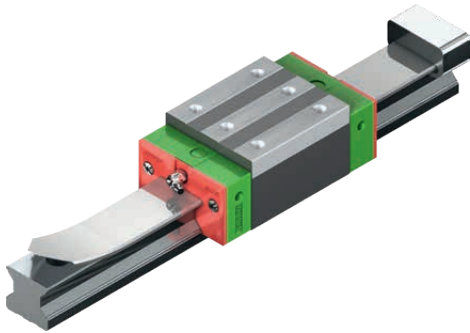

#### Properties:

- Backlash-free
- Exchangeable
- Very high load ratings
- Very high rigidity
- Low displacement forces even with high preload
- Cover strip

### 3.6.1 Order code of CRG series

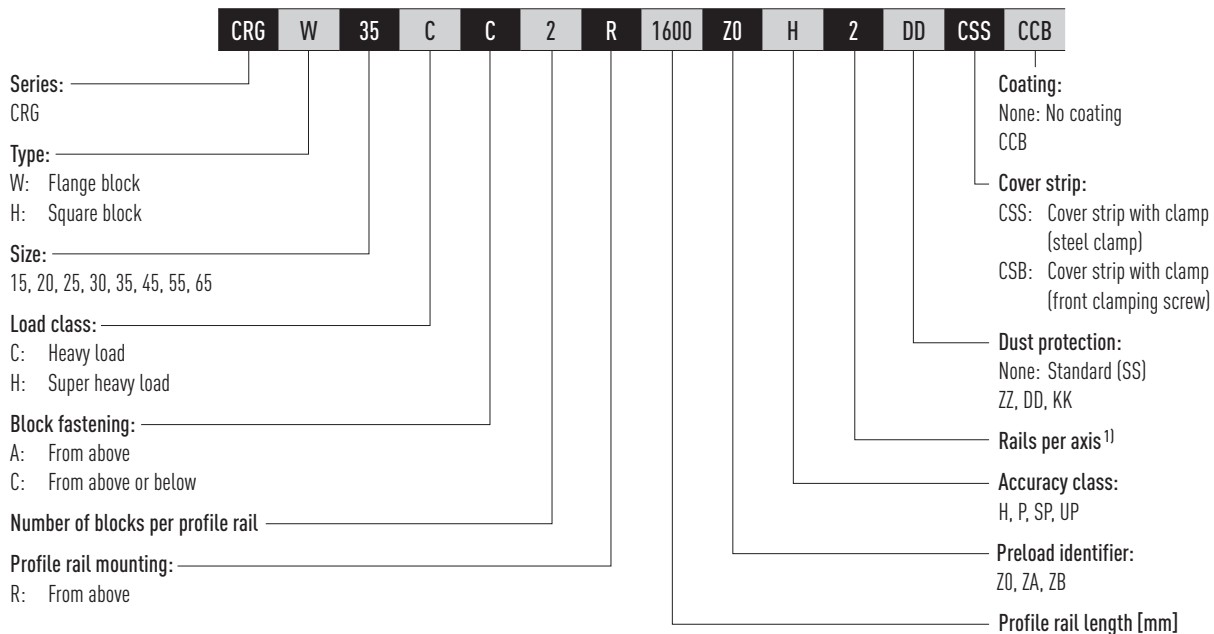

### Interchangeable models

– Order code of CRG block

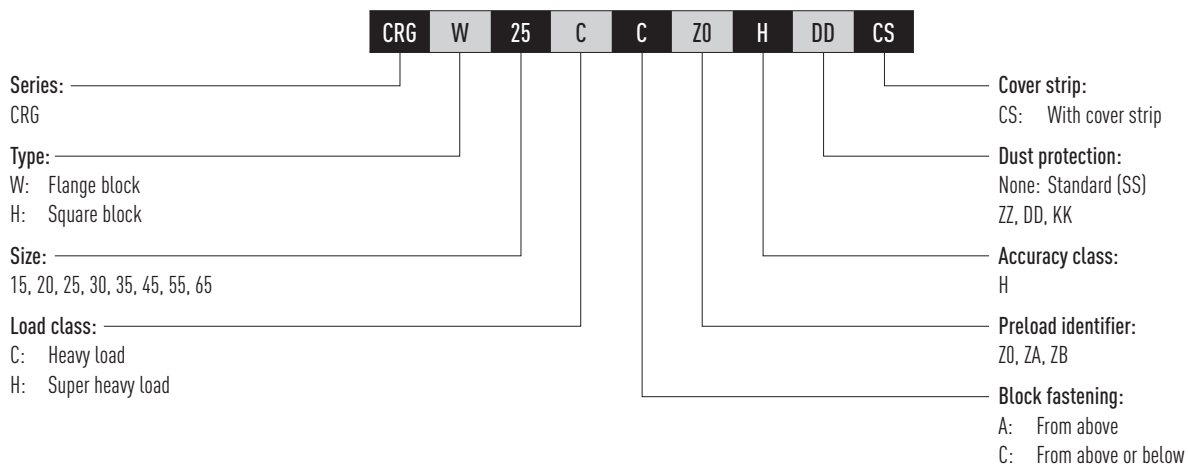

– Order code of CRG profile rail

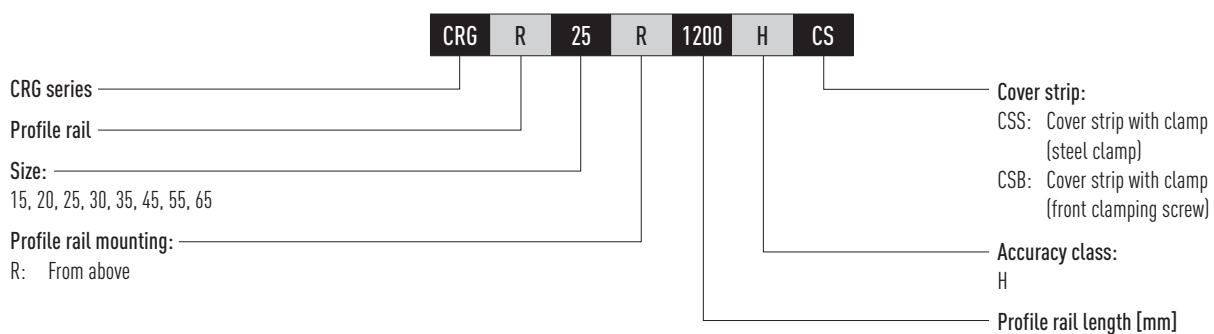

Note:

<sup>1)</sup> The number 2 is also a quantity indication, i.e. one piece of the article described above consists of one pair of rails. No number is given for single profile rails. In the case of multi-part rails, the joint is offset as standard.

# Linear guideways

## CRG series

### 3.6.2 Block types

HIWIN offers block and flange blocks for its linear guideways. Due to the low installation height and the larger mounting surface, flange blocks are better suited for large loads.

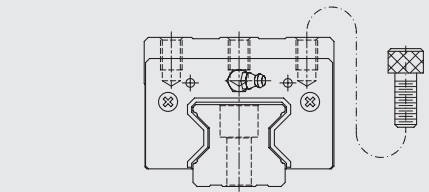
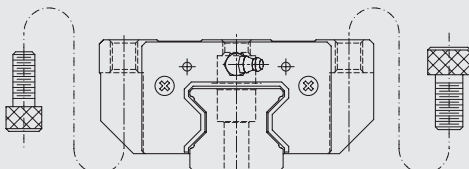
Type	Series/size	Layout	Height [mm]	Typical applications
<b>Square type</b>	CRGH-CA CRGH-HA		28 - 90	<ul style="list-style-type: none"> <li>- Automation technology</li> <li>- Transport technology</li> <li>- CNC machining centres</li> <li>- High performance cutting machines</li> <li>- CNC grinding machines</li> <li>- Injection moulding machines</li> <li>- Portal milling machines</li> </ul>
<b>Flange type</b>	CRGW-CC CRGW-HC		24 - 90	<ul style="list-style-type: none"> <li>- Machines and systems with high required rigidity</li> <li>- Machines and systems with high required load ratings</li> <li>- Spark erosion machines</li> </ul>

### 3.6.3 Profile rail type

Profile rail with standard fastening from above.

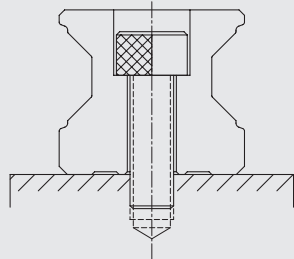
Fastening from above

CRGR_R

### 3.6.4 Preload

#### Definition

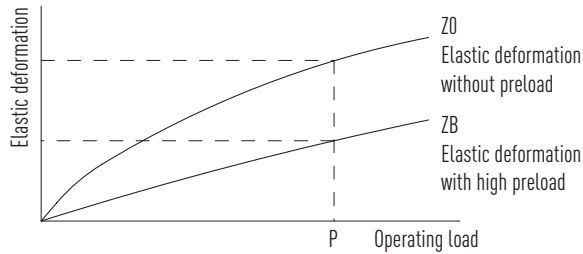
Each linear guideway can be preloaded via the ball size. The curve shows that the rigidity doubles at high preload. The RG/QR series of linear guideways offers three standard preloads for different applications and conditions.



#### Preload identifier

Identifier	Preload		Application
Z0	Slight preload	0.02 – 0.04 $C_{dyn}$	Constant load direction, low jolting and low required accuracy
ZA	Medium preload	0.07 – 0.09 $C_{dyn}$	High precision required
ZB	High preload	0.12 – 0.14 $C_{dyn}$	Very high rigidity and precision required, vibration and jolting

The figure shows the relationship between rigidity, frictional resistance and nominal service life. For smaller size models, preload is not recommended above ZA to avoid preload-related reductions in service life.

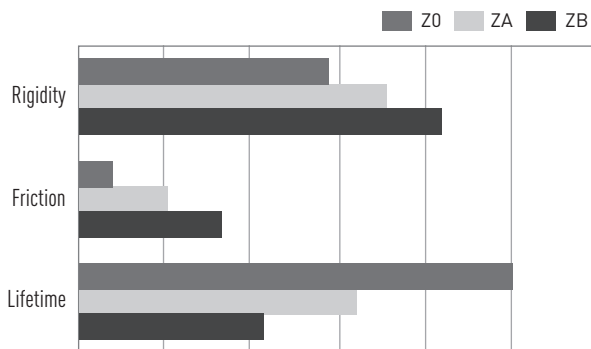

# Linear guideways

## CRG series

### 3.6.5 Load ratings and torques

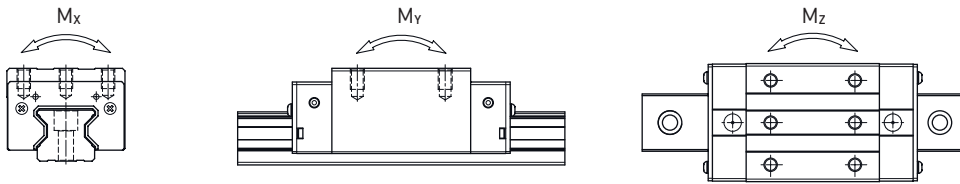

Table 3.93 Load ratings and torques for CRG series

Series/Size	Dynamic load rating $C_{dyn}$ [N] <sup>1)</sup>	Static load rating $C_0$ [N]	Static moment [Nm]		
			$M_{0x}$	$M_{0y}$	$M_{0z}$
CRG_15C	11,300	24,000	311	173	173
CRG_20C	21,300	46,700	647	460	460
CRG_20H	26,900	63,000	872	837	837
CRG_25C	27,700	57,100	758	605	605
CRG_25H	33,900	73,400	975	991	991
CRG_30C	39,100	82,100	1,445	1,060	1,060
CRG_30H	48,100	105,000	1,846	1,712	1,712
CRG_35C	57,900	105,200	2,170	1,440	1,440
CRG_35H	73,100	142,000	2,930	2,600	2,600
CRG_45C	92,600	178,800	4,520	3,050	3,050
CRG_45H	116,000	230,900	6,330	5,470	5,470
CRG_55C	130,500	252,000	8,010	5,400	5,400
CRG_55H	167,800	348,000	11,150	10,250	10,250
CRG_65C	213,000	411,600	16,200	11,590	11,590
CRG_65H	275,300	572,700	22,550	22,170	22,170

<sup>1)</sup> Dynamic load rating for 100,000 m travel path

### 3.6.6 Rigidity

The rigidity depends on the preload. With the formula F 3.15, the deformation can be calculated depending on the rigidity.

F 3.20

$$\delta = \frac{P}{k}$$

$\delta$  Deformation [ $\mu\text{m}$ ]  
 P Operating load [N]  
 k Rigidity value [N/ $\mu\text{m}$ ]

Table 3.94 Radial rigidity of CRG series

Load type	Series/ Size	Rigidity depending on the preload		
		Z0	ZA	ZB
Heavy load	CRG_15C	482	504	520
	CRG_20C	586	614	633
	CRG_25C	682	717	740
	CRG_30C	809	849	876
	CRG_35C	954	1,002	1,035
	CRG_45C	1,433	1,505	1,554
	CRG_55C	1,515	1,591	1,643
	CRG_65C	2,120	2,227	2,300
Super heavy load	CRG_20H	786	823	848
	CRG_25H	873	917	947
	CRG_30H	1,083	1,136	1,173
	CRG_35H	1,280	1,344	1,388
	CRG_45H	1,845	1,938	2,002
	CRG_55H	2,079	2,182	2,254
	CRG_65H	2,931	3,077	3,178

Unit: N/ $\mu\text{m}$

# Linear guideways

## CRG series

### 3.6.7 Dimensions of the CRG blocks

#### 3.6.7.1 CRGH dimensions

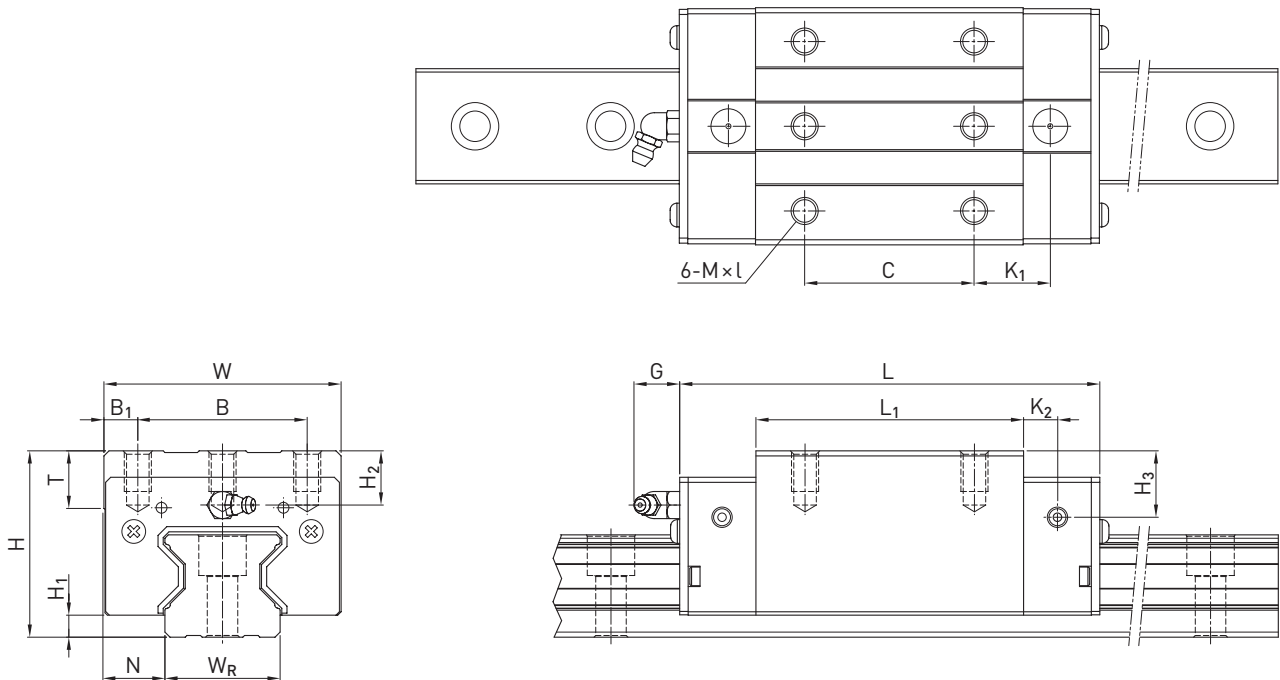

Table 3.95 Dimensions of the block

Series/size	Installation dimensions [mm]			Dimensions of the block [mm]													Load ratings [N]		Weight [kg]
	H	H <sub>1</sub>	N	W	B	B <sub>1</sub>	C	L <sub>1</sub>	L	K <sub>1</sub>	K <sub>2</sub>	G	M × l	T	H <sub>2</sub>	H <sub>3</sub>	C <sub>dyn</sub>	C <sub>0</sub>	
CRGH15CA	28	4.0	9.5	34	26	4.0	26	45.0	68.0	13.40	4.70	5.3	M4 × 8	6.0	7.6	10.1	11,300	24,000	0.20
CRGH20CA	34	5.0	12.0	44	32	6.0	36	57.5	86.0	15.80	6.00	5.3	M5 × 8	8.0	8.3	8.3	21,300	46,700	0.40
CRGH20HA							50	77.5	106.0	18.80							26,900	63,000	0.53
CRGH25CA	40	5.5	12.5	48	35	6.5	35	64.5	97.9	20.75	7.25	12.0	M6 × 8	9.5	10.2	10.0	27,700	57,100	0.61
CRGH25HA							50	81.0	114.4	21.50							33,900	73,400	0.75
CRGH30CA	45	6.0	16.0	60	40	10.0	40	71.0	109.8	23.50	8.00	12.0	M8 × 10	9.5	9.5	10.3	39,100	82,100	0.90
CRGH30HA							60	93.0	131.8	24.50							48,100	105,000	1.16
CRGH35CA	55	6.5	18.0	70	50	10.0	50	73.0	124.0	22.50	10.00	12.0	M8 × 12	12.0	16.0	19.6	57,900	105,200	1.57
CRGH35HA							72	106.5	151.5	25.25							73,100	142,000	2.06
CRGH45CA	70	8.0	20.5	86	60	13.0	60	106.0	153.2	31.00	10.00	12.9	M10 × 17	16.0	20.0	24.0	92,600	178,800	3.18
CRGH45HA							80	139.8	187.0	37.90							116,000	230,900	4.13
CRGH55CA	80	10.0	23.5	100	75	12.5	75	125.5	183.7	37.75	12.50	12.9	M12 × 18	17.5	22.0	27.5	130,500	252,000	4.89
CRGH55HA							95	173.8	232.0	51.90							167,800	348,000	6.68
CRGH65CA	90	12.0	31.5	126	76	25.0	70	160.0	232.0	60.80	15.80	12.9	M16 × 20	25.0	15.0	15.0	213,000	411,600	8.89
CRGH65HA							120	223.0	295.0	67.30							275,300	572,700	12.13

## 3.6.7.2 CRGW dimensions

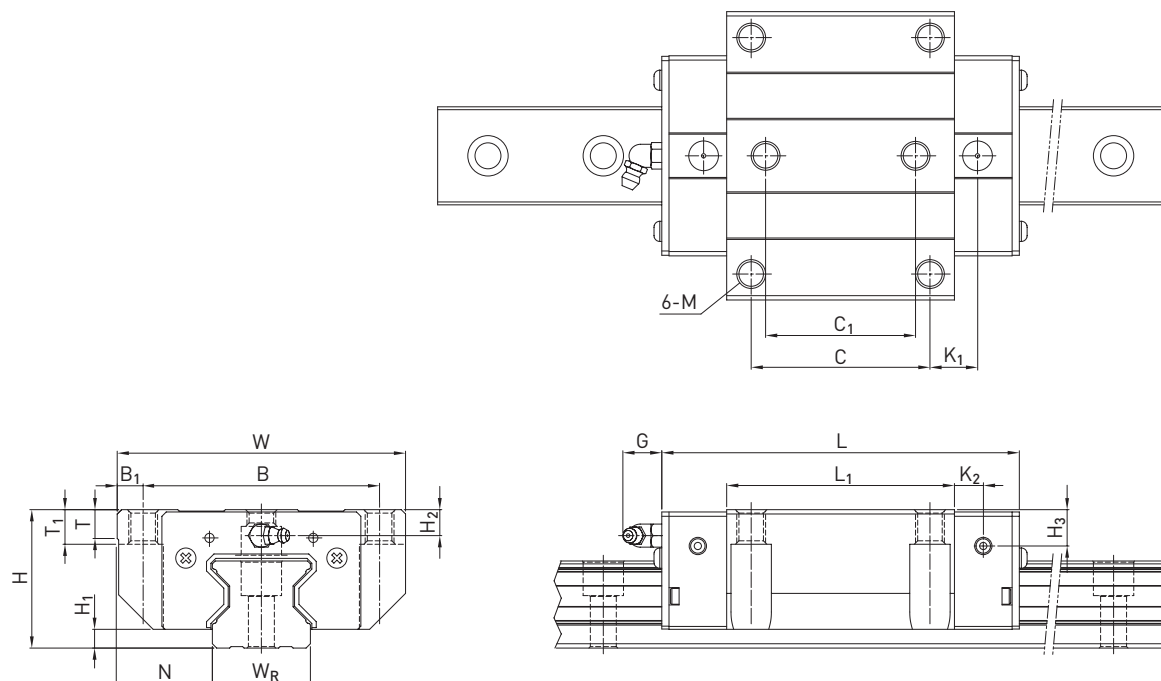

Table 3.96 Dimensions of the block

Series/size	Installation dimensions [mm]			Dimensions of the block [mm]															Load ratings [N]		Weight [kg]
	H	H <sub>1</sub>	N	W	B	B <sub>1</sub>	C	C <sub>1</sub>	L <sub>1</sub>	L	K <sub>1</sub>	K <sub>2</sub>	G	M	T	T <sub>1</sub>	H <sub>2</sub>	H <sub>3</sub>	C <sub>dyn</sub>	C <sub>0</sub>	
CRGW15CC	24	4.0	16.0	47	38	4.5	30	26	45.0	68.0	11.40	4.70	5.3	M5	6.0	6.95	3.6	6.1	11,300	24,000	0.22
CRGW20CC	30	5.0	21.5	63	53	5.0	40	35	57.5	86.0	13.80	6.00	5.3	M6	8.0	10.00	4.3	4.3	21,300	46,700	0.47
CRGW20HC									77.5	106.0	23.80	26,900							63,000	0.63	
CRGW25CC	36	5.5	23.5	70	57	6.5	45	40	64.5	97.9	15.75	7.25	12.0	M8	9.5	10.00	6.2	6.0	27,700	57,100	0.72
CRGW25HC									81.0	114.4	24.00	33,900							73,400	0.91	
CRGW30CC	42	6.0	31.0	90	72	9.0	52	44	71.0	109.8	17.50	8.00	12.0	M10	9.5	10.00	6.5	7.3	39,100	82,100	1.16
CRGW30HC									93.0	131.8	28.50	48,100							105,000	1.52	
CRGW35CC	48	6.5	33.0	100	82	9.0	62	52	79.0	124.0	16.50	10.00	12.0	M10	12.0	13.00	9.0	12.6	57,900	105,200	1.75
CRGW35HC									106.5	151.5	30.25	73,100							142,000	2.40	
CRGW45CC	60	8.0	37.5	120	100	10.0	80	60	106.0	153.2	21.00	10.00	12.9	M12	14.0	15.00	10.0	14.0	92,600	178,800	3.43
CRGW45HC									139.8	187.0	37.90	116,000							230,900	4.57	
CRGW55CC	70	10.0	43.5	140	116	12.0	95	70	125.5	183.7	27.75	12.50	12.9	M14	16.0	17.00	12.0	17.5	130,500	252,000	5.43
CRGW55HC									173.8	232.0	51.90	167,800							348,000	7.61	
CRGW65CC	90	12.0	53.5	170	142	14.0	110	82	160.0	232.0	40.80	15.80	12.9	M16	22.0	23.00	15.0	15.0	213,000	411,600	11.63
CRGW65HC									223.0	295.0	72.30	275,300							572,700	16.58	

# Linear guideways

## CRG series

### 3.6.8 Dimensions of the CRG rail

#### 3.6.8.1 Dimensions CRGR\_R

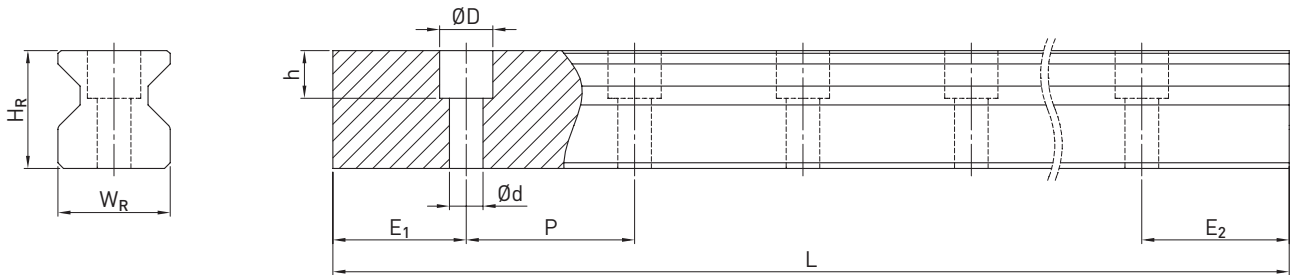

Table 3.97 Dimensions of profile rail CRGR\_R

Series/size	Assembly screw for rail [mm]	Dimensions of the rail [mm]						Max. length [mm]	Max. length E <sub>1</sub> = E <sub>2</sub> [mm]	Min. length [mm]	E <sub>1/2</sub> min [mm] <sup>1)</sup>	E <sub>1/2</sub> min [mm] <sup>2)</sup>	E <sub>1/2</sub> max [mm]	Weight [kg/m]
		W <sub>R</sub>	H <sub>R</sub>	D	h	d	P							
CRGR15R	M4 × 20	15	16.5	7.5	5.7	4.5	30.0	4,000	3,960.0	72	6	14	24.0	1.70
CRGR20R	M5 × 25	20	21.0	9.5	8.5	6.0	30.0	4,000	3,960.0	74	7	16	23.0	2.66
CRGR25R	M6 × 30	23	23.6	11.0	9.0	7.0	30.0	4,000	3,960.0	76	8	17	22.0	3.08
CRGR30R	M8 × 35	28	28.0	14.0	12.0	9.0	40.0	4,000	3,920.0	98	9	18	31.0	4.41
CRGR35R	M8 × 35	34	30.2	14.0	12.0	9.0	40.0	4,000	3,920.0	98	9	24	31.0	6.06
CRGR45R	M12 × 45	45	38.0	20.0	17.0	14.0	52.5	4,000	3,937.5	129	12	27	40.5	9.97
CRGR55R	M14 × 55	53	44.0	23.0	20.0	16.0	60.0	4,000	3,900.0	148	14	29	46.0	13.98
CRGR65R	M16 × 65	63	53.0	26.0	22.0	18.0	75.0	4,000	3,900.0	180	15	30	60.0	20.22

<sup>1)</sup> E<sub>1/2</sub> min without cover strip and with cover strip (clamp: steel clamp)

<sup>2)</sup> E<sub>1/2</sub> min with cover strip (clamp: front clamping screw)

#### 3.6.8.2 Calculation of the length of profile rails

HIWIN offers profile rails in customised lengths. To make sure the end of the profile rail does not become unstable, the value E should not exceed half the distance between the mounting holes (P). At the same time, the value E<sub>1/2</sub> should be between E<sub>1/2</sub> min and E<sub>1/2</sub> max so that the mounting hole does not break out.

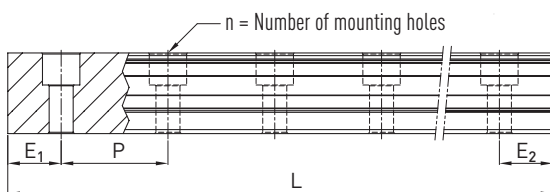

F 3.21

$$L = (n - 1) \times P + E_1 + E_2$$

L Total length of the profile rail [mm]

n Number of mounting holes

P Distance between two mounting holes [mm]

E<sub>1/2</sub> Distance from the centre of the last mounting hole to the end of the profile rail [mm].

**3.6.8.3 Steel clamp**

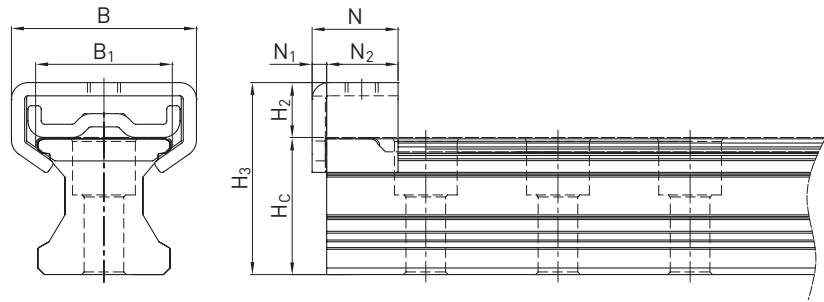

Table 3.98 Dimensions of CRG profile rail with steel clamp

Series/size	Dimensions of the rail with steel clamp [mm]							
	H <sub>3</sub>	H <sub>R</sub>	H <sub>C</sub>	N	N <sub>1</sub>	N <sub>2</sub>	B	B <sub>1</sub>
CRG_15	20.5	16.7	3.8	15	2.2	12.8	21.00	15.8
CRG_20	28.4	21.2	7.2	13	2.2	10.8	28.00	20.7
CRG_25	33.8	23.8	10.0	15	2.2	12.8	30.70	23.9
CRG_30	37.4	28.2	9.2	12	2.2	9.8	34.00	28.9
CRG_35	41.6	30.4	11.2	18	2.2	15.8	40.00	34.8
CRG_45	50.2	38.2	12.0	18	2.2	15.8	53.58	45.6
CRG_55	55.4	44.2	11.2	18	2.2	15.8	58.60	53.7
CRG_65	65.2	53.2	12.0	18	2.2	15.8	71.80	63.6

**3.6.8.4 Front-side clamping screw**

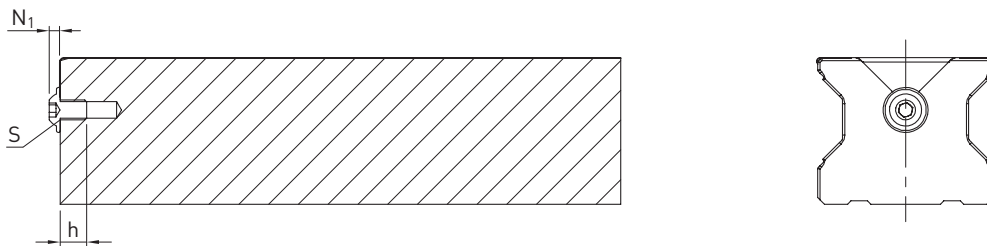

Table 3.99 Dimensions of front-side clamping screw

Series/Size	S [mm]	h [mm]	N <sub>1</sub> [mm]
CRG_15	M3	5	1.65
CRG_20	M4	5	2.20
CRG_25	M4	5	2.20
CRG_30	M4	5	2.20
CRG_35	M6	9	3.30
CRG_45	M6	9	3.30
CRG_55	M6	9	3.30
CRG_65	M6	9	3.30

# Linear guideways

## CRG series

### 3.6.9 Sealing systems

Different sealing systems are available for HIWIN blocks. You can find an overview on Page 24. The following table shows the total length of the blocks with different sealing systems. Appropriate sealing systems are available for these sizes.

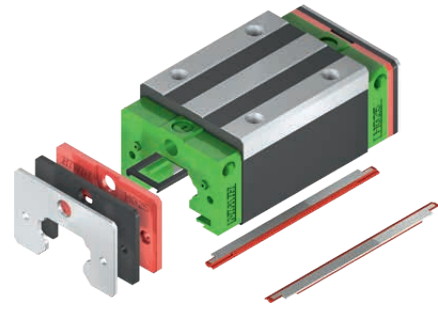

Table 3.100 Total length of block with different sealing systems

Series/size	Total length L (including screws)			
	SS	ZZ	DD	KK
CRG15C	68.0	70.0	72.4	74.4
CRG20C	86.0	88.0	90.4	92.4
CRG20H	106.0	108.0	110.4	112.4
CRG25C	97.9	99.9	102.3	104.3
CRG25H	114.4	116.4	118.8	120.8
CRG30C	109.8	112.8	114.6	117.6
CRG30H	131.8	134.8	136.6	139.6
CRG35C	124.0	127.0	129.0	132.0
CRG35H	151.5	154.5	156.5	159.5
CRG45C	153.2	156.2	160.4	163.4
CRG45H	187.0	190.0	194.2	197.2
CRG55C	183.7	186.7	190.9	193.9
CRG55H	232.0	235.0	239.2	242.2
CRG65C	232.0	235.0	240.8	243.8
CRG65H	295.0	298.0	303.8	306.8

Unit: mm

#### 3.6.9.1 Designation of the seal sets

The seal sets are always shipped complete with the installation materials and include the supplemental parts for the standard seal.

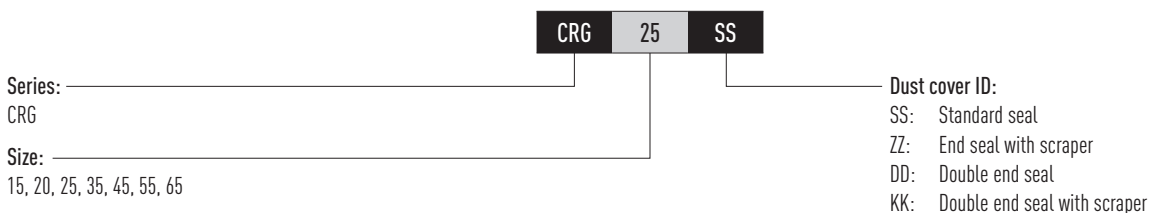

### 3.6.10 Tolerances depending on the accuracy class

The CRG series are available in four accuracy classes according to the parallelism between block and rail, height accuracy H and width accuracy N. The selection of the accuracy class is determined by the requirements of the machine.

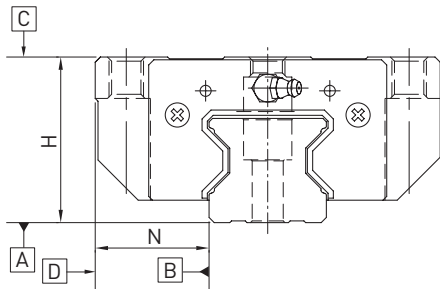

#### 3.6.10.1 Parallelism

Parallelism of locating surfaces D and B of the block and rail and of top block surface C to mounting surface A of the rail. Ideal installation of the linear guideway and the measurement in the centre of the block are prerequisites.

Table 3.101 Tolerance of parallelism between block and profile rail

Rail length [mm]	Accuracy class			
	H	P	SP	UP
– 100	7	3	2	2
100 – 200	9	4	2	2
200 – 300	10	5	3	2
300 – 500	12	6	3	2
500 – 700	13	7	4	2
700 – 900	15	8	5	3
900 – 1100	16	9	6	3
1100 – 1500	18	11	7	4
1500 – 1900	20	13	8	4
1900 – 2500	22	15	10	5
2500 – 3100	25	18	11	6
3100 – 3600	27	20	14	7
3600 – 4000	28	21	15	7

Unit:  $\mu\text{m}$

# Linear guideways

## CRG series

### 3.6.10.2 Accuracy – height and width

#### Height tolerance of H

Permissible absolute dimension deviation of height H, measured between the centre of bolting surface C and rail underside A, with any position of the block on the rail.

#### Height variance of H

Permissible deviation of height H between several blocks on one rail, measured at the same position of the rail.

#### Width tolerance of N

Permissible absolute dimension deviation of width N, measured between the centre of bolting surfaces D and B, with any position of the block on the rail.

#### Width variance of N

Permissible deviation of width N between several blocks on one rail, measured at the same position of the rail.

Series/size	Accuracy class	Height tolerance of H	Width tolerance of N	Height variance of H	Width variance of N
<b>CRG_15, 20</b>	H (high)	± 0.03	± 0.03	0.01	0.01
	P (precision)	0/- 0.03 <sup>1)</sup> ± 0.015 <sup>2)</sup>	0/- 0.03 <sup>1)</sup> ± 0.015 <sup>2)</sup>	0.006	0.006
	SP (super precision)	0/- 0.015	0/- 0.015	0.004	0.004
	UP (ultra precision)	0/- 0.008	0/- 0.008	0.003	0.003
<b>CRG_25, 30, 35</b>	H (high)	± 0.04	± 0.04	0.015	0.015
	P (precision)	0/- 0.04 <sup>1)</sup> ± 0.02 <sup>2)</sup>	0/- 0.04 <sup>1)</sup> ± 0.02 <sup>2)</sup>	0.007	0.007
	SP (super precision)	0/- 0.02	0/- 0.02	0.005	0.005
	UP (ultra precision)	0/- 0.01	0/- 0.01	0.003	0.003
<b>CRG_45, 55</b>	H (high)	± 0.05	± 0.05	0.015	0.02
	P (precision)	0/- 0.05 <sup>1)</sup> ± 0.025 <sup>2)</sup>	0/- 0.05 <sup>1)</sup> ± 0.025 <sup>2)</sup>	0.007	0.01
	SP (super precision)	0/- 0.03	0/- 0.03	0.005	0.007
	UP (ultra precision)	0/- 0.02	0/- 0.02	0.003	0.005
<b>CRG_65</b>	H (high)	± 0.07	± 0.07	0.02	0.025
	P (precision)	0/- 0.07 <sup>1)</sup> ± 0.035 <sup>2)</sup>	0/- 0.07 <sup>1)</sup> ± 0.035 <sup>2)</sup>	0.01	0.015
	SP (super precision)	0/- 0.05	0/- 0.05	0.007	0.01
	UP (ultra precision)	0/- 0.03	0/- 0.03	0.005	0.007

Unit: mm

<sup>1)</sup> Assembled linear guideway

<sup>2)</sup> Unassembled linear guideway

### 3.6.10.3 Permissible tolerances of the mounting surface

Once the requirements for the accuracy of the mounting surfaces are met, the high accuracy, rigidity and service life of the RG/QR series linear guideways are achieved.

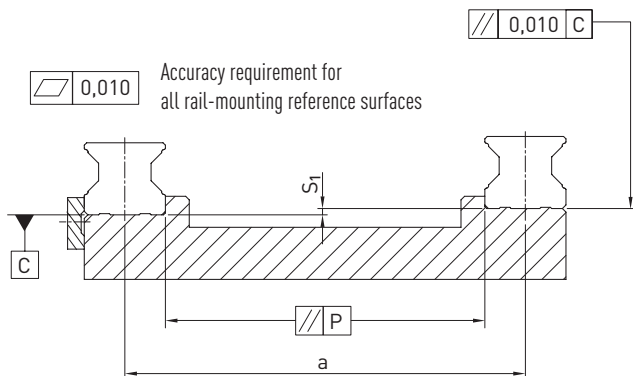

#### Tolerance of parallelism of reference surface (P)

Series/Size	Preload class		
	Z0	ZA	ZB
CRG_15	5	3	3
CRG_20	8	6	4
CRG_25	9	7	5
CRG_30	11	8	6
CRG_35	14	10	7
CRG_45	17	13	9
CRG_55	21	14	11
CRG_65	27	18	14

Unit:  $\mu\text{m}$

#### Tolerance of height of reference surface ( $S_1$ )

F 3.22  $S_1 = a \times K - T_H$

- $S_1$  Maximum height tolerance [mm]
- $a$  Distance between rails [mm]
- $K$  Coefficient of height tolerance
- $T_H$  Tolerance of height according to Table 3.102

Series/Size	Preload class		
	Z0	ZA	ZB
CRG_15 – 65	$2.2 \times 10^{-4}$	$1.7 \times 10^{-4}$	$1.2 \times 10^{-4}$

Note: If  $S_1 < 0$ , select another tolerance class!

# Linear guideways

CRG series

## Height tolerance for mounting surface on block

- The height tolerance of the reference surface when two or more blocks are used in parallel ( $S_2$ )

 Accuracy requirement for all block-mounting reference surfaces

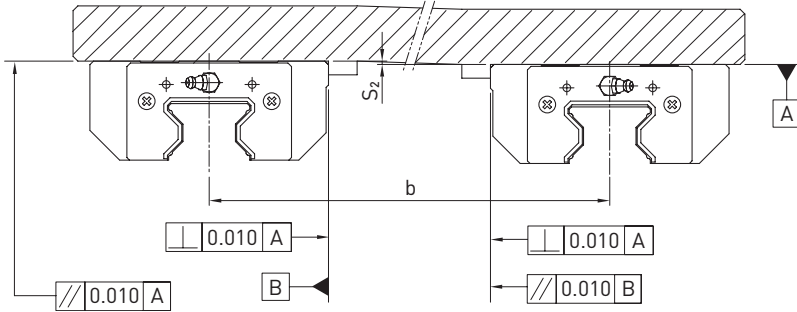

**F 3.23**  $S_2 = b \times 4,2 \times 10^{-5}$

$S_2$  Maximum height tolerance [mm]  
 $b$  Distance between blocks [mm]

- The height tolerance of the reference surface when two or more blocks are used in parallel ( $S_3$ )

 Accuracy requirement for all block-mounting reference surfaces

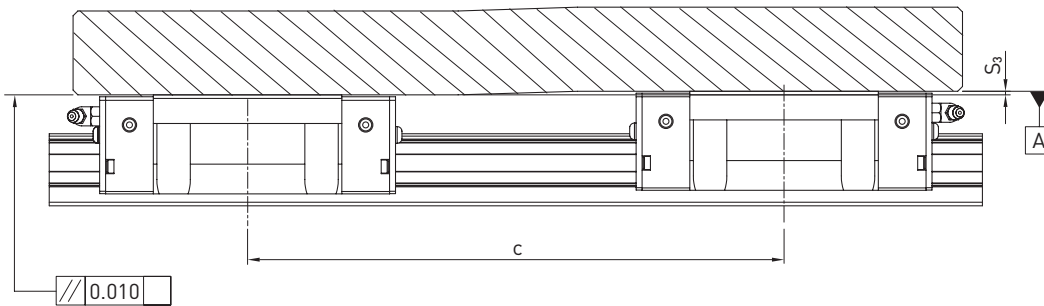

**F 3.24**  $S_3 = c \times 4,2 \times 10^{-5}$

$S_3$  Maximum height tolerance [mm]  
 $c$  Distance between blocks [mm]

**3.6.11 Shoulder heights and edge roundings**

Inaccurate shoulder heights and edge roundings of mounting surfaces impair accuracy and may conflict with the block or rail profile. The following shoulder heights and edge profiles must be observed to avoid assembly problems.

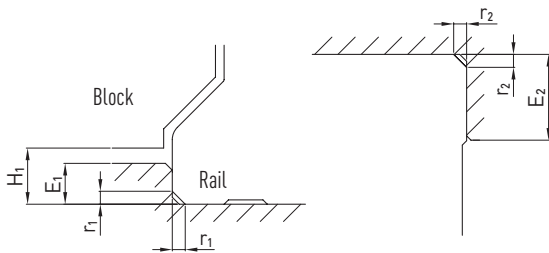

Table 3.105 **Shoulder heights and edge roundings**

Series/Size	Max. radius of edges $r_1$	Max. radius of edges $r_2$	Shoulder height of the reference edge of rail $E_1$	Shoulder height of the reference edge of block $E_2$	Clearance height under block $H_1$
CRG_15	0.5	0.5	3.0	4.0	4.0
CRG_20	0.5	0.5	3.5	5.0	5.0
CRG_25	1.0	1.0	5.0	5.0	5.5
CRG_30	1.0	1.0	5.0	5.0	6.0
CRG_35	1.0	1.0	6.0	6.0	6.5
CRG_45	1.0	1.0	7.0	8.0	8.0
CRG_55	1.5	1.5	9.0	10.0	10.0
CRG_65	1.5	1.5	10.0	10.0	12.0

Unit: mm

# Linear guideways

## MG series

---

### 3.7 MG series

#### 3.7.1 Properties of the MGN series linear guideway

Miniature type for the most compact applications. The HIWIN linear guideway of the MGN series is based on proven HIWIN technology. The Gothic arch contact design absorbs loads in all directions and is particularly rigid and precise. Given its compact and lightweight design, it is particularly suited to use in small devices.

#### 3.7.2 Layout of MGN series

- Dual-row linear guideways
- Gothic arch contact design
- Rail, block and balls made of corrosion-resistant steel
- Compact and light design
- Balls are secured in the block by retaining wire
- Lubricating nipple available for MGN15
- End seal
- Interchangeable models are available in defined accuracy classes

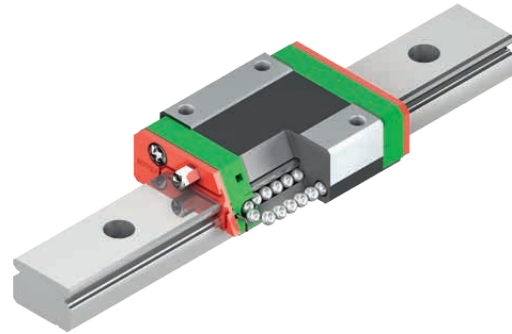

Layout of MGN series

#### 3.7.3 Properties of the MGW series linear guideway

The HIWIN linear guideway of the MGW series is based on proven HIWIN technology. The Gothic arch contact design absorbs loads in all directions and is particularly rigid and precise. Due to the wider rail, compared to the MGN series, the MGW series can absorb significantly higher load moments.

#### 3.7.4 Layout of MGW series

- Dual-row linear guideways
- Gothic arch contact design
- Rail, block and balls made of corrosion-resistant steel
- Compact and light design
- Balls are secured in the block by retaining wire
- Lubricating nipple available for MGW15
- End seal
- Interchangeable models are available in defined accuracy classes

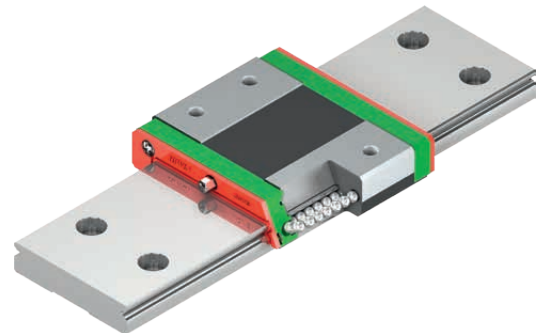

Layout of MGW series

#### 3.7.5 Applications of MG series

The MGN and MGW series can be used in a wide range of applications including the semiconductor industry, PCB assembly, medical technology, robotics, instrumentation, office automation, and other applications requiring miniature guides.

### 3.7.6 Order codes of MG series

For MGN and MGW linear guideways, there is a distinction made between assembled and non-assembled models. The dimensions of both models are the same. The main difference is that, in the unassembled models, blocks and profile rails can be freely interchanged. Block and profile rail can be ordered separately and mounted by the customer.

#### Order code for linear guideway (assembled)

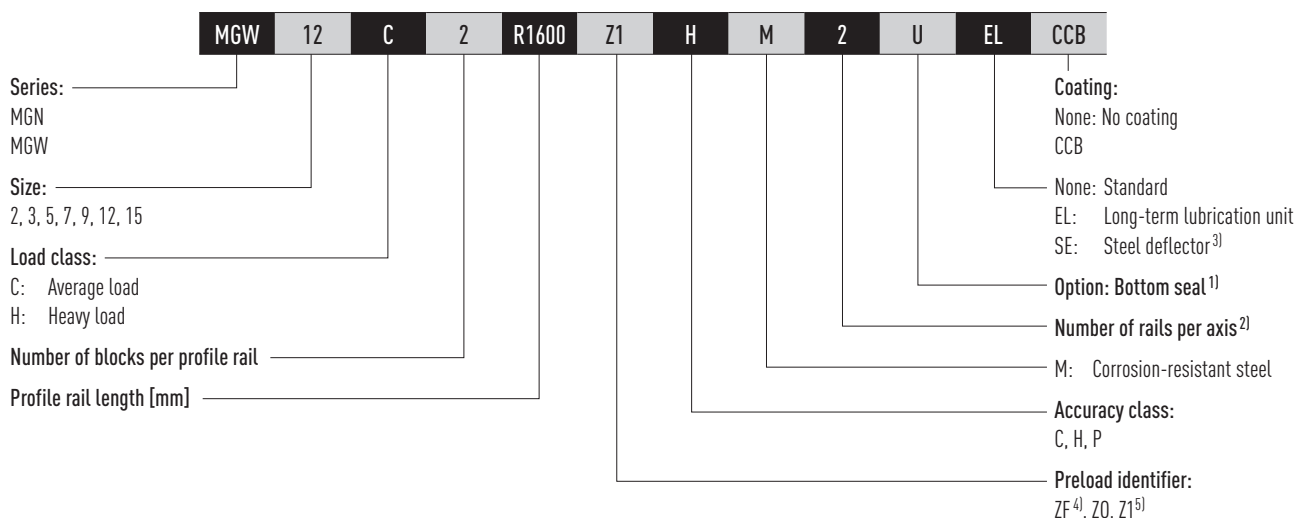

#### Order number of block (not assembled)

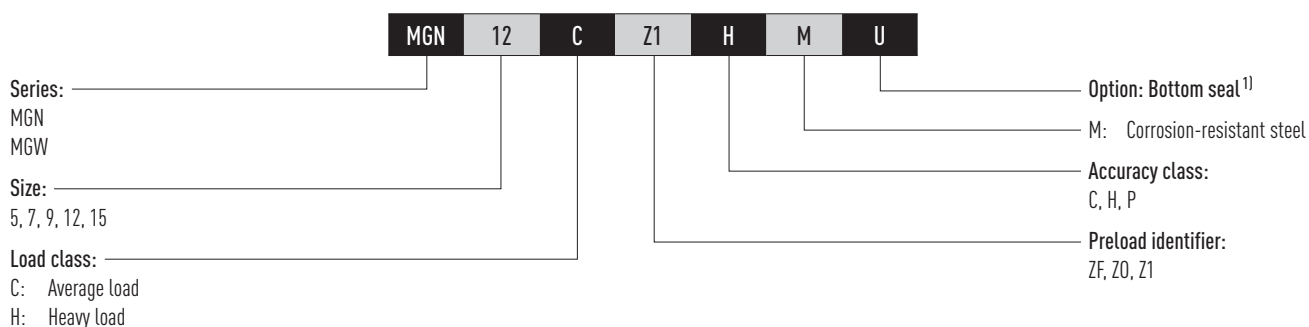

#### Order number of profile rail (not assembled)

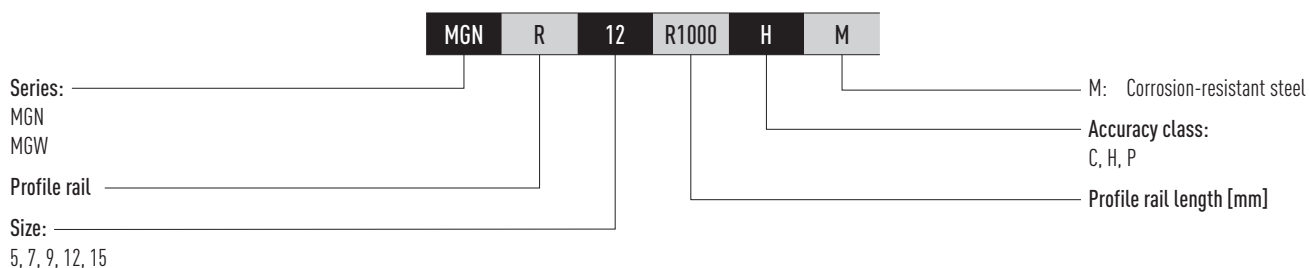

Note:

<sup>1)</sup> Available for MGN and MGW series in sizes 12 and 15.

<sup>2)</sup> The number 2 is also a quantity indication, i.e. one piece of the article described above consists of one pair of rails.  
No number is given for single profile rails. In the case of multi-part rails, the joint is offset as standard.

<sup>3)</sup> Available for MGN07, 09, 12, 15 and MGW12, 15.

<sup>4)</sup> Not available for paired rails and MG05.

<sup>5)</sup> Not available for MG02 and MG03.

# Linear guideways

MG series

## 3.7.7 Block types

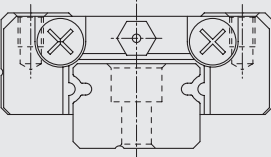
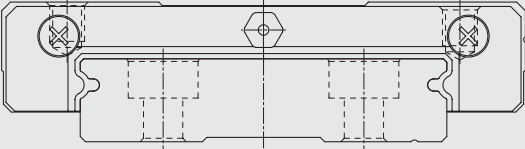
Table 3.106 Block types				
Type	Series/size	Layout	Height [mm]	Typical applications
Narrow type	MGN-C MGN-H		3,2 – 16	<ul style="list-style-type: none"> <li>- Printers</li> <li>- Robots</li> <li>- Precision measuring equipment</li> <li>- Semiconductor industry</li> </ul>
Wide type	MGW-C MGW-H		4 – 16	

## 3.7.8 Profile rail types

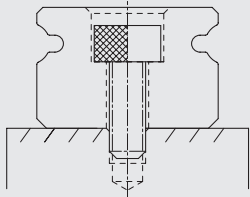
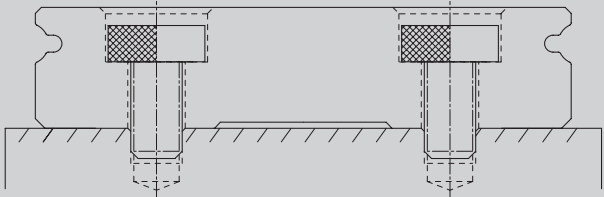
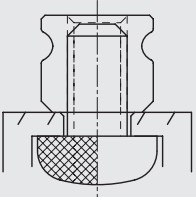
Table 3.107 Profile rail types	
Fastening from above	
	
MGN_R	MGW_R
Fastening from below	
	
MGN_R 02/03	

### 3.7.9 Preload

The MGN/MGW series of linear guideways offers three standard preload classes for different applications.

Table 3.108 Preload identifier

Identifier	Preload	Accuracy class
ZF <sup>1)</sup>	Slight backlash: 4 – 10 µm	C, H
Z0	Reduced play to very light preload: 0 – 3 µm	C – P
Z1 <sup>2)</sup>	Light preload: 0 – 0.02 C <sub>dyn</sub>	C – P

<sup>1)</sup> Not available for size 5

<sup>2)</sup> Not available for size 2 and 3

### 3.7.10 Load ratings and torques

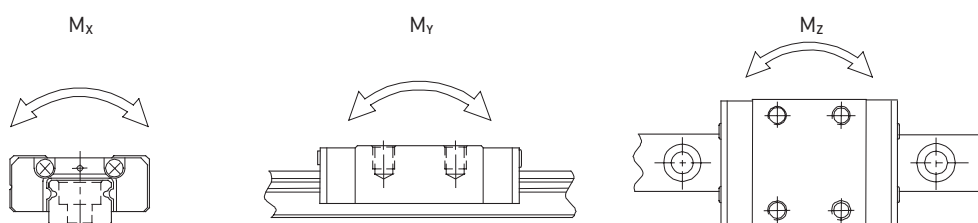

Table 3.109 Load ratings and torques for MG series

Series/Size	Dynamic load rating C <sub>dyn</sub> [N] <sup>1)</sup>	Static load rating C <sub>0</sub> [N]	Static moment [Nm]		
			M <sub>0x</sub>	M <sub>0y</sub>	M <sub>0z</sub>
MGN02C	220	400	0.4	0.6	0.6
MGN03C	290	440	0.7	0.5	0.5
MGN03H	390	680	1.0	1.3	1.3
MGN05C	540	840	2.0	1.3	1.3
MGN05H	670	1,080	2.6	2.3	2.3
MGN07C	980	1,245	4.7	2.8	2.8
MGN07H	1,370	1,960	7.6	4.8	4.8
MGN09C	1,860	2,550	11.8	7.4	7.4
MGN09H	2,550	4,020	19.6	18.6	18.6
MGN12C	2,840	3,920	25.5	13.7	13.7
MGN12H	3,720	5,880	38.2	36.3	36.3
MGN15C	4,610	5,590	45.1	21.6	21.6
MGN15H	6,370	9,110	73.5	57.8	57.8
MGW02C	410	730	1.1	2.2	2.2
MGW03C	540	840	2.3	1.3	1.3
MGW03H	680	1180	3.3	2.7	2.7
MGW05C	680	1,180	5.5	2.7	2.7
MGW07C	1,370	2,060	15.7	7.1	7.1
MGW07H	1,770	3,140	23.5	15.5	15.5
MGW09C	2,750	4,120	40.1	18.0	18.0
MGW09H	3,430	5,890	54.5	34.0	34.0
MGW12C	3,920	5,590	70.3	27.8	27.8
MGW12H	5,100	8,240	102.7	57.4	57.4
MGW15C	6,770	9,220	199.3	56.7	56.7
MGW15H	8,930	13,380	299.0	122.6	122.6

<sup>1)</sup> Dynamic load rating for 50,000 m travel path

# Linear guideways

## MG series

### 3.7.11 Rigidity

The rigidity depends on the preload. With the formula F 3.25, the deformation can be calculated depending on the rigidity.

F 3.25

$$\delta = \frac{P}{k}$$

$\delta$  Deformation [ $\mu\text{m}$ ]  
 $P$  Operating load [N]  
 $k$  Rigidity value [N/ $\mu\text{m}$ ]

Table 3.110 Radial rigidity of MGN series

Load type	Series/ Size	Rigidity depending on the preload	
		Z0	Z1
Average load	MGN07C	26	33
	MGN09C	37	48
	MGN12C	44	56
	MGN15C	57	74
Heavy load	MGN07H	39	51
	MGN09H	56	73
	MGN12H	63	81
	MGN15H	87	113

Unit: N/ $\mu\text{m}$

Table 3.111 Radial rigidity of MGW series

Load type	Series/ Size	Rigidity depending on the preload	
		Z0	Z1
Average load	MGW07C	38	49
	MGW09C	55	71
	MGW12C	63	81
	MGW15C	78	101
Heavy load	MGW07H	54	70
	MGW09H	74	95
	MGW12H	89	114
	MGW15H	113	145

Unit: N/ $\mu\text{m}$

## 3.7.12 Dimensions of the MG blocks

### 3.7.12.1 MGN

MGN02, MGN03

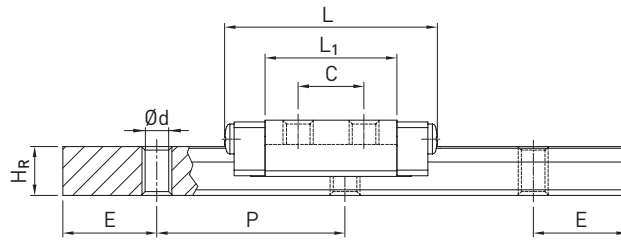
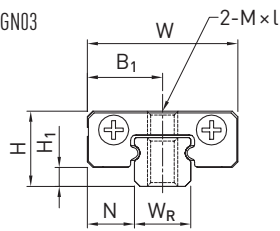

MGN05

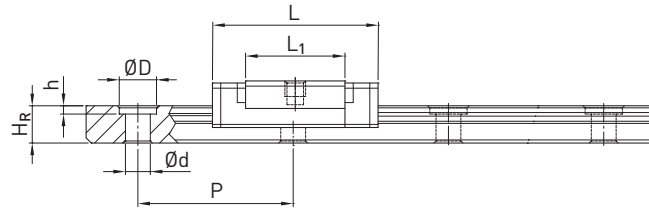
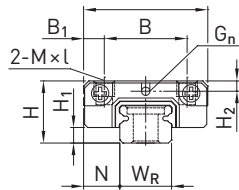

MGN07, MGN09, MGN12

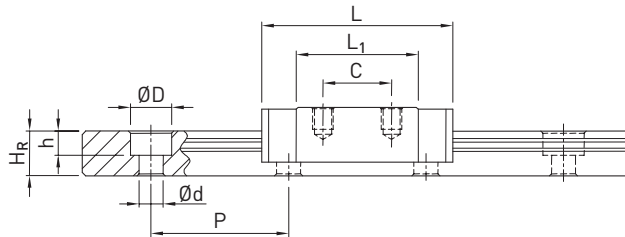
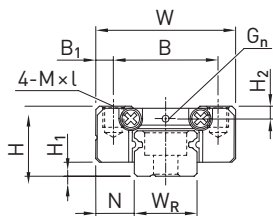

MGN15

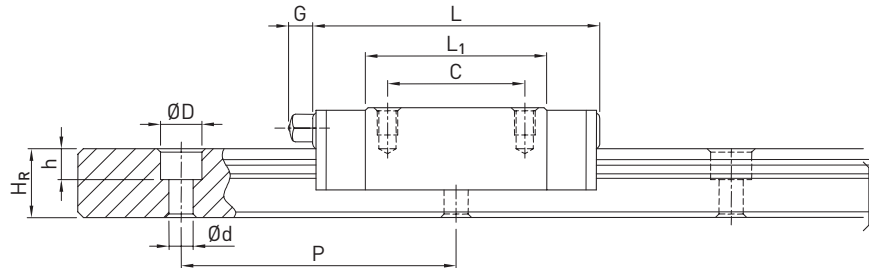
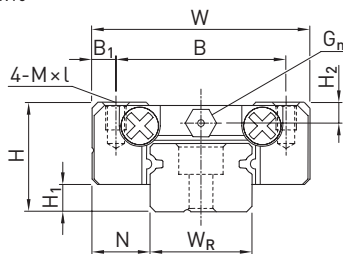

Table 3.112 Dimensions of the block

Series/size	Installation dimensions [mm]			Dimensions of the block [mm]										Load ratings [N]		Weight [kg]
	H	H <sub>1</sub>	N	W	B	B <sub>1</sub>	C	L <sub>1</sub>	L	G	G <sub>n</sub>	M × l	H <sub>2</sub>	C <sub>dyn</sub>	C <sub>0</sub>	
MGN02C	3,2	0,7	2,0	6	—	3	4,0	9,4	12,5	—	—	M1,4	—	220	400	0,001
MGN03C	4,0	1,0	2,5	8	—	4	3,5	7,0	11,3	—	—	M1,6	—	290	440	0,001
MGN03H							5,5	11	15,3			M2		390	680	0,002
MGN05C	6	1,5	3,5	12	8	2,0	—	9,6	16,0	—	Ø 0,8	M2 × 1,0	1,0	540	840	0,008
MGN05H							—	12,6	19,0	—		1,5		670	1,080	0,010
MGN07C	8	1,5	5,0	17	12	2,5	8	13,5	22,5	—	Ø 1,2	M2 × 2,5	1,5	980	1,245	0,010
MGN07H							13	21,8	30,8					1,372	1,960	0,020
MGN09C	10	2,0	5,5	20	15	2,5	10	18,9	28,9	—	Ø 1,4	M3 × 3	1,8	1,860	2,550	0,020
MGN09H							16	29,9	39,9					2,550	4,020	0,030
MGN12C	13	3,0	7,5	27	20	3,5	15	21,7	34,7	—	Ø 2	M3 × 3,5	2,5	2,840	3,920	0,030
MGN12H							20	32,4	45,4					3,720	5,880	0,050
MGN15C	16	4,0	8,5	32	25	3,5	20	26,7	42,1	4,5	M3	M3 × 4	3,0	4,610	5,590	0,060
MGN15H							25	43,4	58,8					6,370	9,110	0,090

For dimensions of the rail, see Page 137, for standard as well as optional lubrication adapter, see Page 152.

The size MGN02 and MGN03 blocks are only available mounted on the profile rail.

# Linear guideways

## MG series

### 3.7.12.2 MGW

#### MGW02

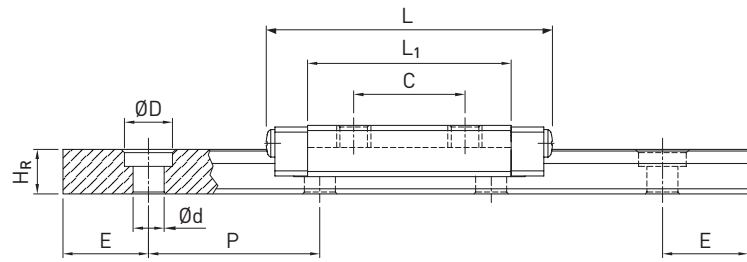
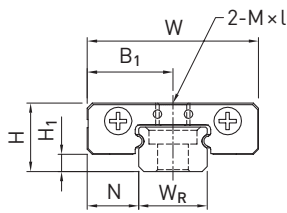

#### MGW05

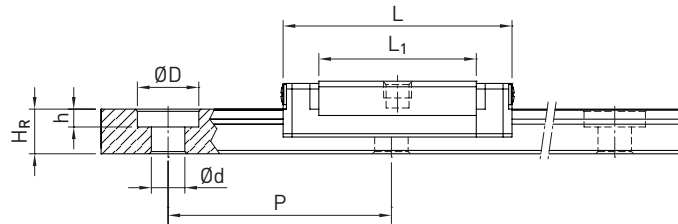
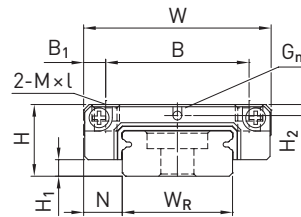

#### MGW03, MGW07, MGW09, MGW12

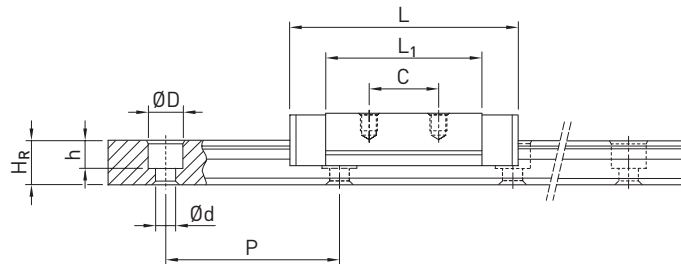
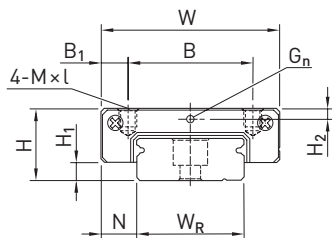

#### MGW15

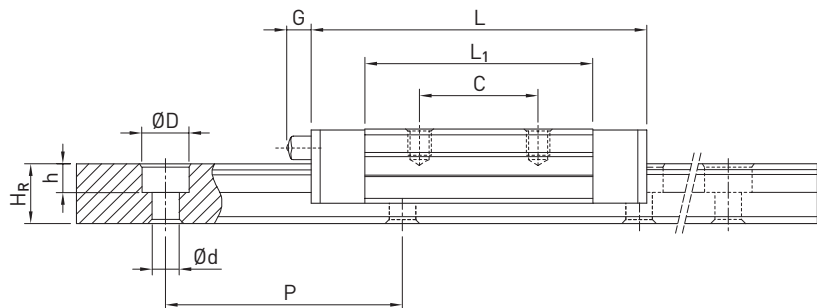
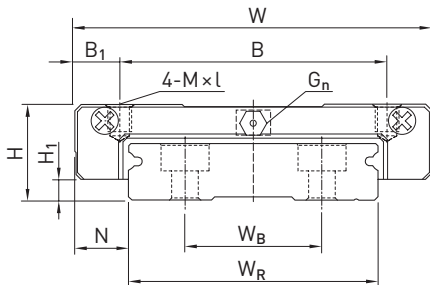

Table 3.113 Dimensions of the block

Series/size	Installation dimensions [mm]			Dimensions of the block [mm]										Load ratings [N]		Weight [kg]
	H	H <sub>1</sub>	N	W	B	B <sub>1</sub>	C	L <sub>1</sub>	L	G	G <sub>n</sub>	M × l	H <sub>2</sub>	C <sub>dyn</sub>	C <sub>0</sub>	
MGW02C	4,0	1	3	10	—	5	6,5	11,9	16,7	—	—	M2	—	410	730	0,002
MGW03C	4,5	1	3	12	—	6	4,5	9,60	15,0	—	Ø0,5	M2	0,65	540	840	0,003
MGW03H							8,0	14,2	19,6					680	1,180	0,004
MGW05C	6,5	1,5	3,5	17	13	2,0	—	14,1	20,5	—	Ø0,8	M2,5 × 1,5	1,00	680	1,180	0,02
MGW07C	9,0	1,9	5,5	25	19	3,0	10	21,0	31,2	—	Ø1,2	M3 × 3	1,85	1,370	2,060	0,02
MGW07H							19	30,8	41,0					1,770	3,140	0,03
MGW09C	12,0	2,9	6,0	30	21	4,5	12	27,5	39,3	—	Ø1,4	M3 × 3	2,40	2,750	4,120	0,04
MGW09H					23	3,5	24	38,5	50,7					3,430	5,890	0,06
MGW12C	14,0	3,4	8,0	40	28	6,0	15	31,3	46,1	—	Ø2	M3 × 3,6	2,80	3,920	5,590	0,07
MGW12H							28	45,6	60,4					5,100	8,240	0,10
MGW15C	16,0	3,4	9,0	60	45	7,5	20	38,0	54,8	5,2	M3	M4 × 4,2	3,20	6,770	9,220	0,14
MGW15H							35	57,0	73,8					8,930	13,380	0,22

For dimensions of the rail, see Page 137, for standard as well as optional lubrication adapter, see Page 152.

The size MG02 and MG03 blocks are only available mounted on the profile rail.

### 3.7.13 Dimensions of the MG profile rail

#### 3.7.13.1 Dimensions MGN\_R

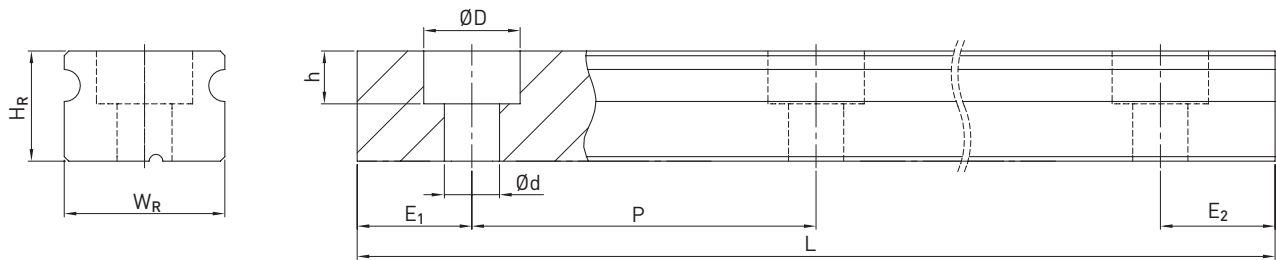

Table 3.114 Dimensions of profile rail MGN\_R

Series/size	Assembly screw for rail [mm]	Dimensions of the rail [mm]						Max. length [mm]	Max. length $E_1 = E_2$ [mm]	Min. length [mm]	$E_{1/2}$ min [mm]	$E_{1/2}$ max [mm]	Weight [kg/m]
		$W_R$	$H_R$	$D$	$h$	$d$	$P$						
MGNR02R	M1	2	2,0		M1		8	250	240	12	2	6	0,03
MGNR03R	M1,6	3	2,6		M1,6		10	250	240	14	2	8	0,05
MGNR05R	M2 × 6 <sup>1)</sup>	5	3,6	3,6	0,8	2,4	15	250	225	23	4	11	0,15
MGNR07R	M2 × 8	7	4,8	4,2	2,3	2,4	15	600	585	25	5	12	0,22
MGNR09R	M3 × 10	9	6,5	6,0	3,5	3,5	20	1,200	1,180	30	5	15	0,38
MGNR12R	M3 × 10	12	8,0	6,0	4,5	3,5	25	2,000	1,975	35	5	20	0,65
MGNR15R	M3 × 12	15	10,0	6,0	4,5	3,5	40	2,000	1,960	52	6	34	1,06

<sup>1)</sup> Special screw (M2 × 0,4 × 6) included.

#### 3.7.13.2 Dimensions MGW\_R

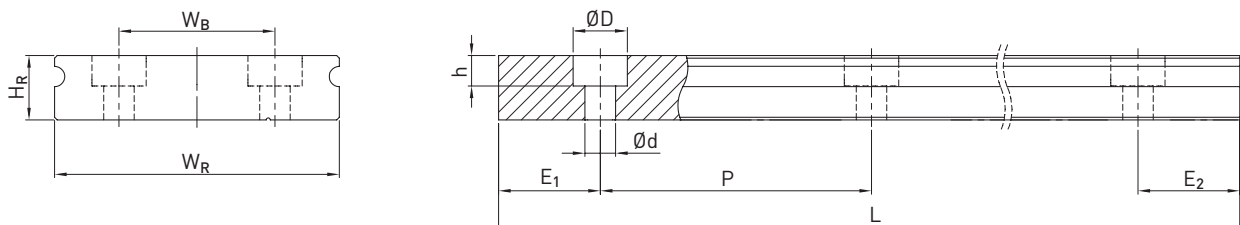

Table 3.115 Dimensions of profile rail MGW\_R

Series/size	Assembly screw for rail [mm]	Dimensions of the rail [mm]							Max. length [mm]	Max. length $E_1 = E_2$ [mm]	Min. length [mm]	$E_{1/2}$ min [mm]	$E_{1/2}$ max [mm]	Weight [kg/m]
		$W_R$	$H_R$	$W_B$	$D$	$h$	$d$	$P$						
MGWR02R	M1,6 × 4,4 <sup>2)</sup>	4	2,6	—	2,8	1,0	1,8	10	250	240	16	3	7	0,70
MGWR03R	M2 × 6 <sup>3)</sup>	6	2,9	—	3,6	1,5	2,4	15	250	225	23	4	11	0,13
MGWR05R	M2,5 × 7 <sup>4)</sup>	10	4,0	—	5,5	1,6	3,0	20	250	220	30	5	11	0,34
MGWR07R	M3 × 8	14	5,2	—	6,0	3,2	3,5	30	600	570	40	5	24	0,51
MGWR09R	M3 × 10	18	7,0	—	6,0	4,5	3,5	30	2,000	1,950	40	5	24	0,91
MGWR12R	M4 × 12	24	8,5	—	8,0	4,5	4,5	40	2,000	1,960	52	6	32	1,49
MGWR15R	M4 × 16	42	9,5	23	8,0	4,5	4,5	40	2,000	1,960	52	6	32	2,86

<sup>2)</sup> Special screw (M1,6 × 0,35 × 4,4) included.

<sup>3)</sup> Special screw (M2 × 0,4 × 6) included.

<sup>4)</sup> Special screw (M2,5 × 0,45 × 7) included.

Note:

1. The tolerance for E is +0,5 to -1 mm for standard, for joint connections 0 to -0,3 mm.
2. If no information is provided on the  $E_{1/2}$  dimensions, the maximum number of mounting holes is determined taking into account  $E_{1/2}$  min.
3. The rails are shortened to the desired length. If no information on the  $E_{1/2}$  dimensions is provided, then the rails are manufactured symmetrically.

# Linear guideways

## MG series

### 3.7.13.3 Calculation of the length of profile rails

HIWIN offers profile rails in customised lengths. To make sure the end of the profile rail does not become unstable, the value E should not exceed half the distance between the mounting holes (P). At the same time, the value  $E_{1/2}$  should be between  $E_{1/2}$  min and  $E_{1/2}$  max so that the mounting hole does not break out.

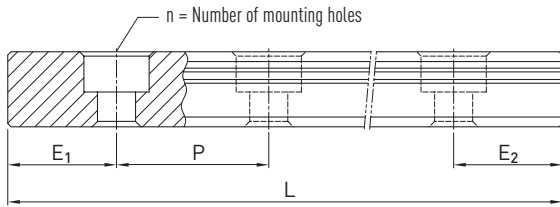

F 3.26

$$L = (n - 1) \times P + E_1 + E_2$$

- L Total length of the profile rail [mm]
- n Number of mounting holes
- P Distance between two mounting holes [mm]
- $E_{1/2}$  Distance from the centre of the last mounting hole to the end of the profile rail [mm].

### 3.7.13.4 Cover caps for mounting holes of profile rails

The cover caps are used to keep the mounting holes free of chips and dirt. The standard plastic cover caps accompany each profile rail. Optional cover caps have to be ordered separately.



Table 3.116 Cover caps for mounting holes of profile rails

Rail	Screw	Article number		Ø D [mm]	Height H [mm]
		Plastic (200 units)	Brass <sup>2)</sup>		
MGNR09R	M3	5-002217 <sup>1)</sup>	5-001340 <sup>1)</sup>	6	1.2
MGNR12R	M3	5-002217	5-001340	6	1.2
MGNR15R	M3	5-002217	5-001340	6	1.2
MGWR09R	M3	5-002217	5-001340	6	1.2
MGWR12R	M4	5-002219	—	8	1.2
MGWR15R	M4	5-002219	—	8	1.2

<sup>1)</sup> Only possible with cylinder head screws with low head acc. to DIN 7984

<sup>2)</sup> Not recommended for coated rails.

### 3.7.14 Sealing system

By default, the blocks of the MG series are equipped with an end seal on both sides to protect against contamination. In addition, sealing strips for the underside of the block can be ordered by adding the code "+U" to the article number. They are optionally available for sizes 12 and 15. For sizes 5, 7 and 9, they cannot be mounted due to limited installation space  $H_1$ . When installing a bottom seal, the lateral mounting surface of the profile rail must not exceed  $H_1$ .

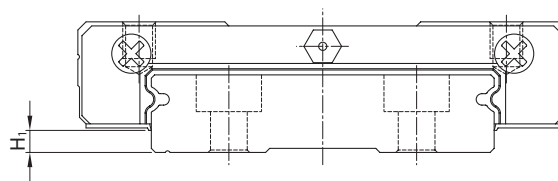

Table 3.117 Installation space  $H_1$

Series/size	Bottom seal	$H_1$	Series/size	Bottom seal	$H_1$
—	—	—	MGW02	—	—
MGN03	—	—	MGW03	—	—
MGN05	—	—	MGW05	—	—
MGN07	—	—	MGW07	—	—
MGN09	—	—	MGW09	—	—
MGN12	●	2.0	MGW12	●	2.6
MGN15	●	3.0	MGW15	●	2.6

### 3.7.15 Long-term lubrication unit

Further information on the lubrication unit can be found in the general information in the "Long-term lubrication unit" section on Page 17. The following drawing shows the dimension (L) for a two-sided lubrication unit. The lubrication unit is always mounted on both sides.

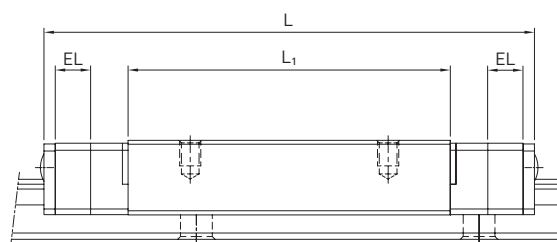

Table 3.118 Dimensions of the block with lubrication unit EL

Block model	Dimensions [mm]			Max. running performance <sup>2)</sup> [km] EL on both sides
	EL	$L_1$	$L^{1)}$	
MGN07C	3,5	13,5	29,5	10.000
MGN07H		21,8	37,8	
MGN09C	5	18,9	38,9	10.000
MGN09H		29,9	49,9	
MGN12C	5	21,7	44,7	10.000
MGN12H		32,4	55,4	
MGW09C	5	27,5	49,3	10.000
MGW09H		38,5	60,7	
MGW12C	5	31,3	56,1	10.000
MGW12H		45,6	70,4	

<sup>1)</sup> Total length with selected dust protection. SS = Standard dust protection

<sup>2)</sup> Further details can be found in the assembly instructions in the "Lubrication" chapter

### 3.7.16 Tolerances depending on the accuracy class

The MG series are available in three accuracy classes according to the parallelism between block and rail, height accuracy H and width accuracy N. The selection of the accuracy class is determined by the requirements of the machine.

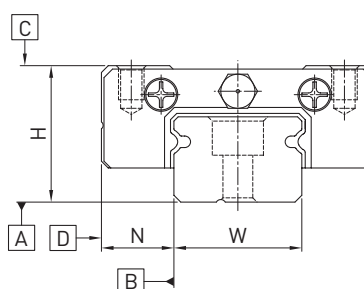

# Linear guideways

## MG series

### 3.7.16.1 Parallelism

Parallelism of locating surfaces D and B of the block and rail and of top block surface

C to mounting surface A of the rail. Ideal installation of the linear guideway and the measurement in the centre of the block are prerequisites.

Table 3.119 Tolerance of parallelism between block and profile rail

Rail length [mm]	Accuracy class		
	C	H	P
- 50	12	6	2.0
50 - 80	13	7	3.0
80 - 125	14	8	3.5
125 - 200	15	9	4.0
200 - 250	16	10	5.0
250 - 315	17	11	5.0
315 - 400	18	11	6.0
400 - 500	19	12	6.0
500 - 630	20	13	7.0
630 - 800	22	14	8.0
800 - 1000	23	16	9.0
1000 - 1200	25	18	11.0
1200 - 1300	25	18	11.0
1300 - 1400	26	19	12.0
1400 - 1500	27	19	12.0
1500 - 1600	28	20	13.0
1600 - 1700	29	20	14.0
1700 - 1800	30	21	14.0
1800 - 1900	30	21	15.0
1900 - 2000	31	22	15.0

Unit:  $\mu\text{m}$

**3.7.16.2 Accuracy – height and width**

**Height tolerance of H**

Permissible absolute dimension deviation of height H, measured between the centre of bolting surface C and rail underside A, with any position of the block on the rail.

**Height variance of H**

Permissible deviation of height H between several blocks on one rail, measured at the same position of the rail.

**Width tolerance of N**

Permissible absolute dimension deviation of width N, measured between the centre of bolting surfaces D and B, with any position of the block on the rail.

**Width variance of N**

Permissible deviation of width N between several blocks on one rail, measured at the same position of the rail.

Table 3.120 Tolerances of width and height

Series/size	Accuracy class	Height tolerance of H	Width tolerance of N	Height variance of H	Width variance of N
MG_02 – MG_15	C (Normal)	± 0.04	± 0.04	0.03	0.03
	H (high)	± 0.02	± 0.025	0.015	0.02
	P (precision)	± 0.01	± 0.015	0.007	0.01

Unit: mm

**3.7.16.3 Permissible tolerances of the mounting surface**

Once the requirements for the accuracy of the mounting surfaces are met, the high accuracy, rigidity and service life of the GG series linear guideways are achieved.

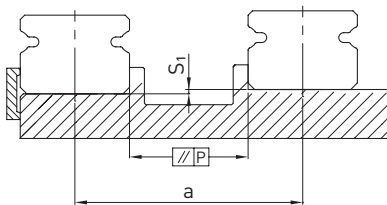

# Linear guideways

## MG series

### Tolerance of parallelism of reference surface (P):

Table 3.121 Maximum tolerance for parallelism (P)

Series/Size	Preload class		
	ZF	Z0	Z1
MG_02	2	2	–
MG_03	2	2	–
MG_05	2	2	2
MG_07	3	3	3
MG_09	4	4	3
MG_12	9	9	5
MG_15	10	10	6

Unit:  $\mu\text{m}$

### Tolerance of height of reference surface (S<sub>1</sub>):

F 3.27  $S_1 = a \times K$

S<sub>1</sub> Maximum height tolerance [mm]

a Distance between rails [mm]

K Coefficient of height tolerance

Table 3.122 Coefficient of height tolerance (K)

Series/Size	Preload class		
	ZF	Z0	Z1
MG_05	$0.4 \times 10^{-4}$	$0.4 \times 10^{-4}$	$0.04 \times 10^{-4}$
MG_07	$0.5 \times 10^{-4}$	$0.5 \times 10^{-4}$	$0.06 \times 10^{-4}$
MG_09	$0.7 \times 10^{-4}$	$0.7 \times 10^{-4}$	$0.12 \times 10^{-4}$
MG_12	$1.0 \times 10^{-4}$	$1.0 \times 10^{-4}$	$0.24 \times 10^{-4}$
MG_15	$1.2 \times 10^{-4}$	$1.2 \times 10^{-4}$	$0.40 \times 10^{-4}$

Table 3.123 Requirements for the mounting surface

Series/Size	Required flatness of the mounting surface
MG_02	0,012/200
MG_03	0,012/200
MG_05	0.015/200
MG_07	0.025/200
MG_09	0.035/200
MG_12	0.050/200
MG_15	0.060/200

Note: The values in the table apply to preload classes ZF and Z0. For Z1 or if more than one rail is mounted on the same surface, the table values must be at least halved.

### 3.7.17 Shoulder heights and edge roundings

Inaccurate shoulder heights and edge roundings of mounting surfaces impair accuracy and may conflict with the block or rail profile. The following shoulder heights and edge profiles must be observed to avoid assembly problems.

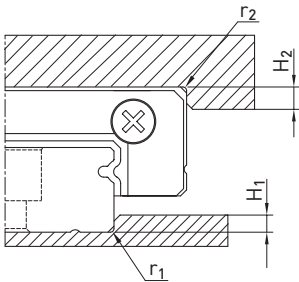

Table 3.124 Shoulder heights and edge roundings

Series/Size	Max. radius of edges $r_1$	Max. radius of edges $r_2$	Shoulder height of $H_1$	Shoulder height of $H_2$
MGN02	0,1	0,2	0,5	1,5
MGN03	0,1	0,2	0,6	1,5
MGN05	0,1	0,2	1,2	2
MGN07	0,2	0,2	1,2	3
MGN09	0,2	0,3	1,7	3
MGN12	0,3	0,4	1,7	4
MGN15	0,5	0,5	2,5	5
MGW02	0,1	0,2	0,6	2,0
MGW03	0,1	0,2	0,6	2,0
MGW05	0,1	0,2	1,2	2
MGW07	0,2	0,2	1,7	3
MGW09	0,3	0,3	2,5	3
MGW12	0,4	0,4	3,0	4
MGW15	0,4	0,8	3,0	5

Unit: mm

# Linear guideways

## PG series

---

### 3.8 PG series

#### 3.8.1 Properties of the PG series linear guideways

The HIWIN linear guideways of the PGC series are a special version of the CG series with integrated HIWIN MAGIC magnetic distance measuring. The magnetic positioning measuring systems of the MAGIC series are optimised for measuring the distances travelled in linear movements.

The reading head is attached to the block and the measuring tape is inserted into the profile rail and protected by the cover tape. The robust housing with electrical shielding and real-time signal output make the PGC profile rail guide the ideal choice for demanding applications in automation, handling or in axes with direct measuring, such as in linear motor axes.

Our MAGIC distance measuring system is also available in a version that is independent of profile rail guides. The position of the magnetic tape and reading head can then be determined at a suitable point, according to the customer's specific requirements. For further details, please refer to the "Linear Motors & Distance Measuring Systems" catalogue.

#### 3.8.2 Layout of PGC series

- Blocks of CG series
- Profile rail of the CG series with additional groove for the measuring tape
- Encoder can be mounted on blocks of sizes CG\_20, CG\_25, CG\_30, CG\_35 and CG\_45
- Mounting direction: When facing the reference edge of the block, the encoder is located on the left side by default. The line of the encoder is also located on the side of the reference edge

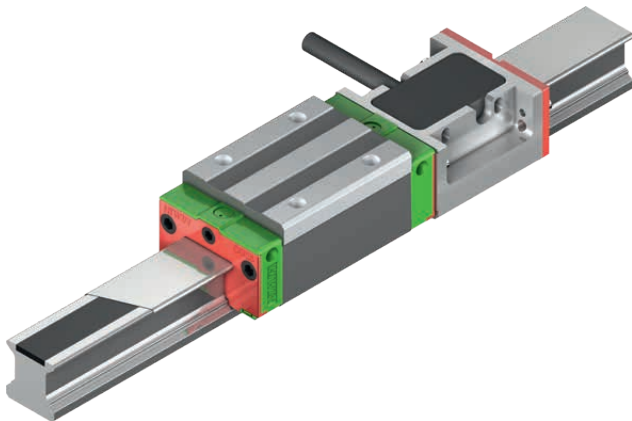

#### Properties:

- Zero contact measurement with 1 V<sub>SS</sub> or digital output
- Digital resolution 1 µm
- Encoder and housing are resistant to dust, humidity, oil and chips
- Encoder with metal housing and IP67 protection mode
- Simple assembly and adjustment
- Signal output in real time
- Special housing for EMC optimisation

### 3.8.3 Order code of PG series

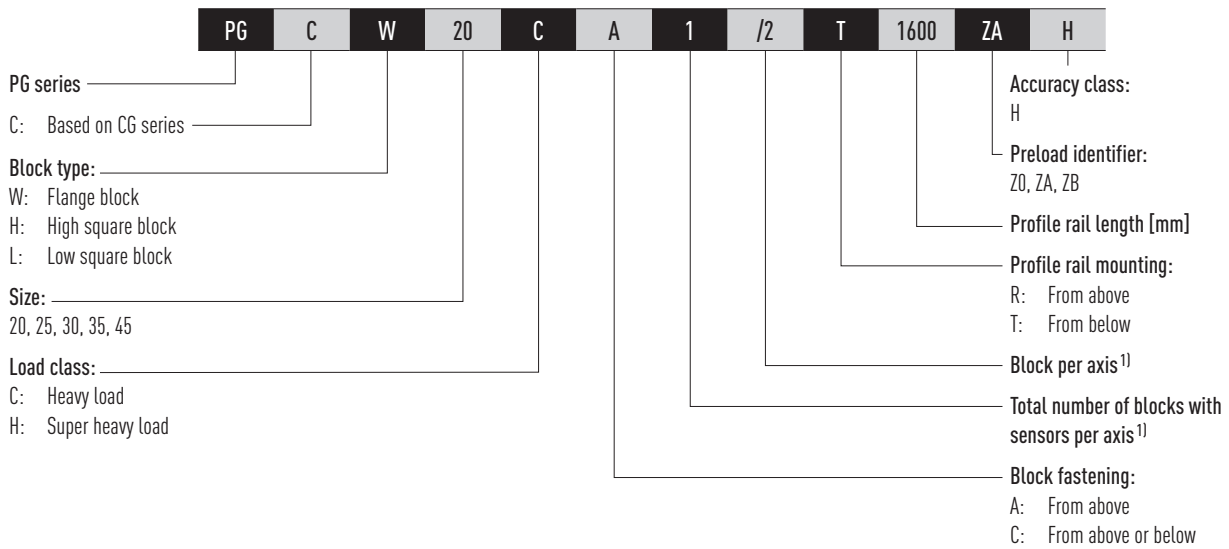

Continuation of order codes of PG series

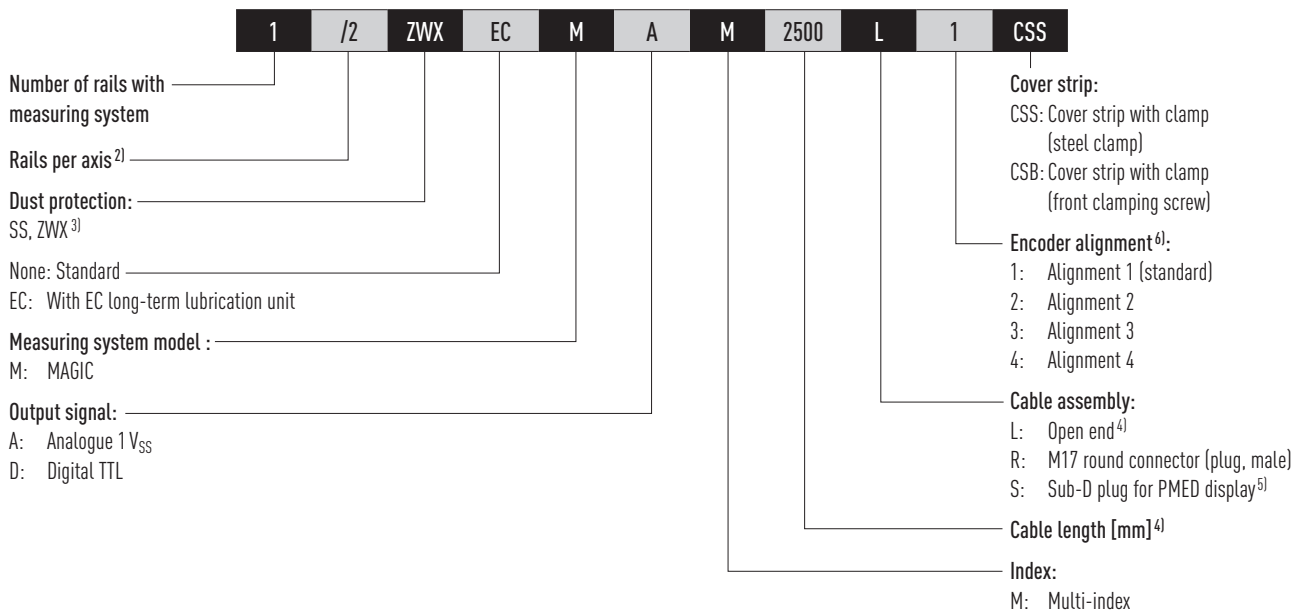

<sup>1)</sup> For the PG series, the total number of blocks per axis is specified (all blocks of the ordered item)

<sup>2)</sup> The number 2 is also a quantity indication, i.e. one piece of the article described above consists of one pair of rails. No number is given for single profile rails. In the case of multi-part rails, the joint is offset as standard.

<sup>3)</sup> If not specified, the block is supplied with standard dust protection (standard end seal and lower sealing strip). For an overview of the different sealing systems, see Page 24

<sup>4)</sup> For open ends, select cable length 1,000 by default (max. length PGC: 1,000 mm)

<sup>5)</sup> The display must be ordered separately

<sup>6)</sup> See section 3.8.6

# Linear guideways

## PG series

### 3.8.4 Dimensions of the PG blocks

The following figure shows an CGH25CA block. It is also possible to attach to the other versions of the CG\_20, CG\_25, CG\_30, CG\_35 and CG\_45 sizes. The overall dimensions then change accordingly. The dimensions of all block sizes are listed in Table 3.125.

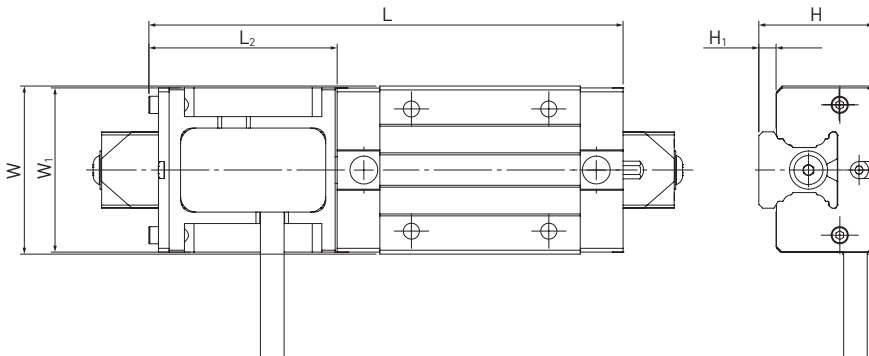

Table 3.125 Dimensions of the blocks including MAGIC-PG housing

Series/Size	L [mm]	L <sub>2</sub> [mm]	W [mm]	W <sub>1</sub> [mm]	H [mm]	H <sub>1</sub> [mm]
CG_20C	121.4	44.0	44	43.0	30	4.6
CG_20H	137.4	44.0	44	43.0	30	4.6
CG_25C	130.5	44.0	48	47.0	40	6.1
CG_25H	147.9	44.0	48	47.0	40	6.1
CG_30C	144.1	44.0	60	58.0	45	7.0
CG_30H	166.6	44.0	60	58.0	45	7.0
CG_35C	158.1	44.0	70	69.0	55	7.6
CG_35H	182.5	44.0	70	69.0	55	7.6
CG_45C	184.3	45.0	86	84.0	70	9.7
CG_45H	220.7	45.0	86	84.0	70	9.7

**3.8.5 Dimensions of the PG rails**

**3.8.5.1 Profile rail with groove, mounting from above (CG series)**

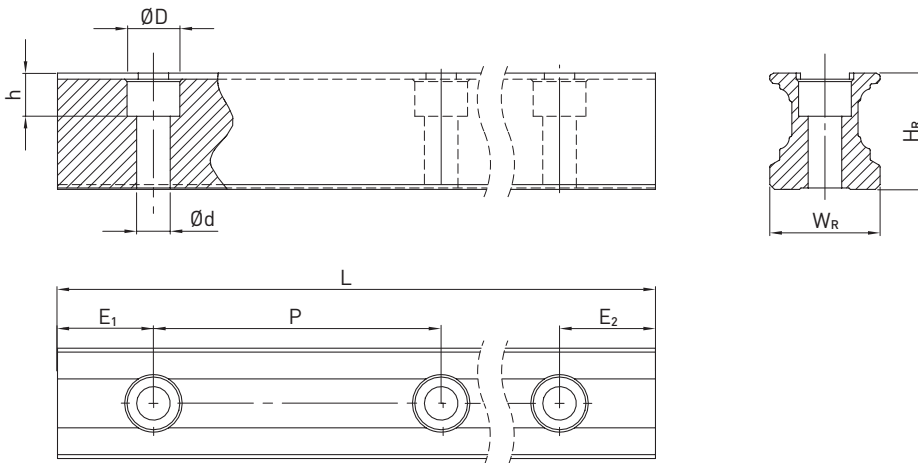

Table 3.126 **Dimensions CGR\_R G1**

Series/size	Dimensions of the rail [mm]						Max. length [mm]	Max. length $E_1 = E_2$ [mm]	$E_{1/2}$ min [mm] <sup>1)</sup>	$E_{1/2}$ min [mm] <sup>2)</sup>	$E_{1/2}$ max [mm]	Weight [kg/m]
	$W_R$	$H_R$	D	h	d	P						
<b>CGR20R G1</b>	20	20.55	9.5	8.5	6.0	60	4,000	3,900	7	16	53	2.05
<b>CGR25R G1</b>	23	24.25	11.0	9.0	7.0	60	4,000	3,900	8	17	52	3.05
<b>CGR30R G1</b>	28	28.35	14.0	12.4	9.0	80	4,000	3,920	9	18	71	5.10
<b>CGR35R G1</b>	34	31.85	14.0	12.0	9.0	80	4,000	3,920	9	24	71	7.14
<b>CGR45R G1</b>	45	39.85	20.0	17.0	14.0	105	4,000	3,885	12	27	93	11.51

<sup>1)</sup>  $E_{1/2}$  min with cover strip (clamp: steel clamp)

<sup>2)</sup>  $E_{1/2}$  min with cover strip (clamp: front clamping screw)

Note: The PGC types always requires the cover strip of the rail to clamp the magnetic tape.

# Linear guideways

## PG series

### 3.8.5.2 Profile rail with groove, mounting from below (CG series)

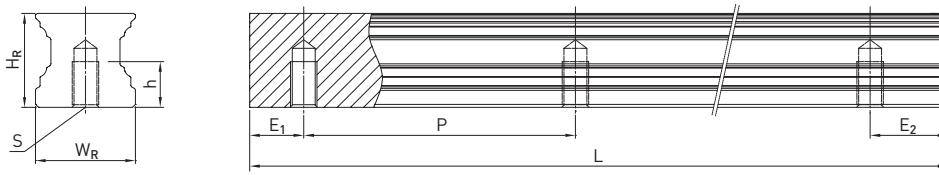

Table 3.127 Dimensions CGR\_T G1

Series/size	Dimensions of the rail [mm]					Max. length [mm]	Max. length $E_1 = E_2$ [mm]	$E_{1/2}$ min [mm] <sup>1)</sup>	$E_{1/2}$ min [mm] <sup>2)</sup>	$E_{1/2}$ max [mm]	Weight [kg/m]
	$W_R$	$H_R$	S	h	P						
<b>CGR20T G1</b>	20	20.55	M6	10	60	4,000	3,900	10	15	53	2.48
<b>CGR25T G1</b>	23	24.25	M6	12	60	4,000	3,900	11	15	52	3.38
<b>CGR30T G1</b>	28	28.35	M8	15	80	4,000	3,920	12	16	71	5.10
<b>CGR35T G1</b>	34	31.85	M8	17	80	4,000	3,920	16	22	71	7.14
<b>CGR45T G1</b>	45	39.85	M12	24	105	4,000	3,885	19	24	93	11.51

<sup>1)</sup>  $E_{1/2}$  min with cover strip (clamp: steel clamp)

<sup>2)</sup>  $E_{1/2}$  min with cover strip (clamp: front clamping screw)

### 3.8.6 Alignment of HIWIN MAGIC-PG encoder

The HIWIN MAGIC-PG encoder can be delivered in alignments 1 to 4 according to the order code (section 3.8.3). If the alignment is not specified, the encoder is delivered with alignment 1 by default.

If there are several blocks on one rail or on a pair of rails, the encoder is mounted on block 1, rail 1 as shown in the following figure. If an alignment deviating from the standard is required, this must be defined in the MAGIC-PG project planning sheet (hiwin.de).

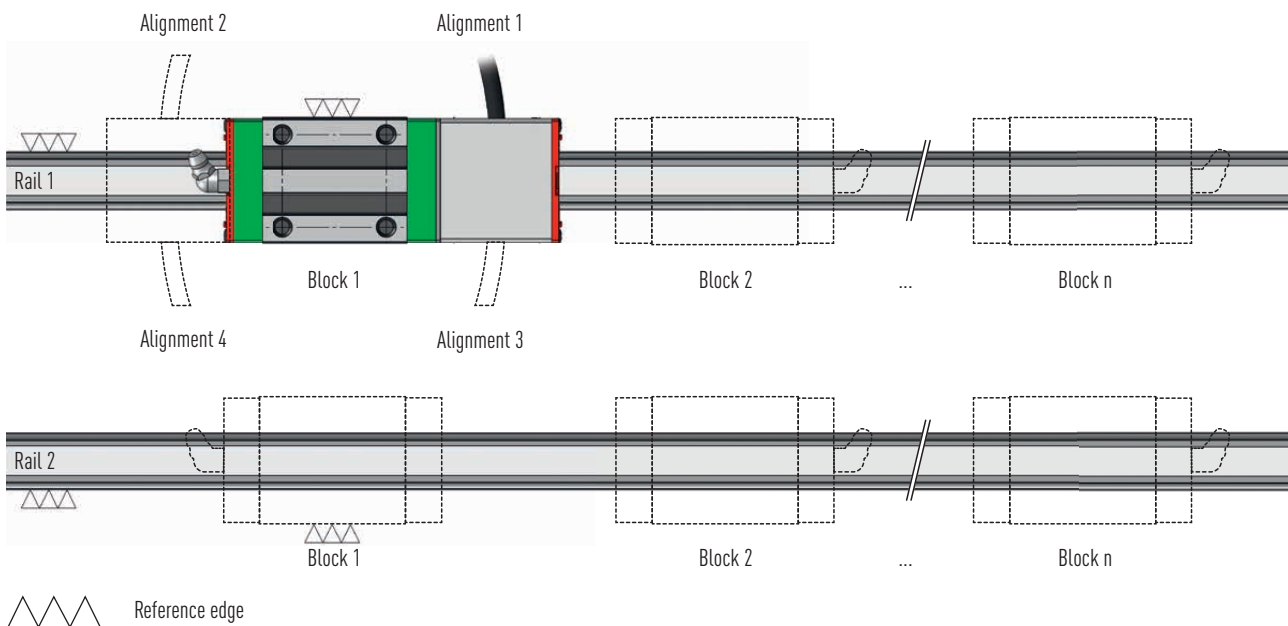

### 3.8.7 Specifications of the HIWIN MAGIC and HIWIN MAGIC-PG positioning measuring systems

	1 V <sub>SS</sub> (analogue)	TTL (digital)
<b>Electrical properties</b>		
<b>Output signal specification</b>	sin/cos, 1 V <sub>SS</sub> (0.85 V <sub>SS</sub> – 1.2 V <sub>SS</sub> )	Quadrature signals acc. to RS-422
<b>Resolution</b>	Infinite, signal period 1 mm	1 µm
<b>Repeatability bidirectional</b>	0.003 mm	0.002 mm
<b>Absolute accuracy</b>	± 20 µm/m	
<b>Reference signal<sup>1)</sup></b>	Periodic index impulse at a distance of 1 mm	
<b>Phase angle</b>	90° ± 0.1° el	90°
<b>DC component</b>	2.5 V ± 0.3 V	—
<b>Distortion factor</b>	Typ. < 0.1 %	—
<b>Operating voltage</b>	5 V ± 5 %	
<b>Power consumption</b>	Typ. 35 mA, max. 70 mA	Typ. 70 mA, max. 120 mA
<b>Max. measurement speed</b>	10 m/s	5 m/s
<b>EMC class</b>	3, according to IEC 801	
<b>Mechanical properties</b>		
<b>Housing material</b>	High-quality aluminium alloy, encoder bottom made of stainless steel	
<b>Max. cable length<sup>2)</sup></b>	PGC: 1,000 mm	
<b>Min. bending radius cable</b>	40 mm	
<b>Protection class</b>	IP67	
<b>Operating temperatures</b>	0 °C to +50 °C	
<b>Weight of MAGIC encoder</b>	80 g	
<b>Weight of MAGIC-PG encoder</b>	80 g	
<b>MAGIC-PG suitable for blocks</b>	HG_20, HG_25, QH_20, QH_25, CG_20, CG_25	

<sup>1)</sup> Can be used e.g. with reference switch

<sup>2)</sup> For use in energy chains, we recommend our pre-assembled encoder cable with a pre-mounted M17 round connector (coupling, female) on one side, which matches the optional M17 round plug connector (male) of the encoder. For details, please contact your HIWIN technician.

Properties	MAGIC-PG	MAGIC
<b>Accuracy class<sup>1)</sup></b>	± 20 µm/m	
<b>Linear expansion coefficient</b>	11.5 × 10 <sup>-6</sup> m/K	
<b>Period</b>	1 mm	
<b>Thickness magnetic scale</b>	1.70 ± 0.10 mm	
<b>Thickness magnetic scale + protective cover tape</b>	—	1.85 ± 0.15 mm
<b>Width</b>	10.05 ± 0.10 mm	
<b>Maximum length</b>	24 m	
<b>Magnetic remanence</b>	> 240 mT	
<b>Pole pitch (distance north – south pole)</b>	1 mm	
<b>single reference marks</b>	Optional	
<b>Material</b>	Elastomers, nitrile and EPDM	
<b>Temperature range</b>	0 °C to +50 °C	
<b>Weight</b>	70 g/m	

<sup>1)</sup> At 20 °C

# Linear guideways

PG series

Magnetic tape separate (left) without cover strip and integrated in a guide rail (right) with stainless steel cover strip

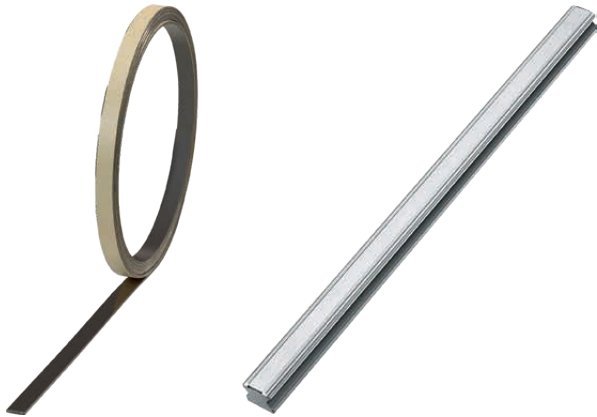

## 3.8.8 Connection of MAGIC positioning measuring system

### 3.8.8.1 Line assignment (for analogue and digital variants)

A high-quality 8-core cable is used, each V1+, V1-, V2+, V2- and V0+, V0- (or A,  $\bar{A}$ , B,  $\bar{B}$  and Z,  $\bar{Z}$  for the digital variant) twisted in pairs.

For use in energy chains, we generally recommend our pre-assembled extension

cables, which are specially designed for use in energy chains. The extension cables are supplied with a single-sided M17 round plug connector (coupling, female) or a customer-specific version.

### 3.8.8.2 Formats and outputs

#### Signal format sin/cos 1 V<sub>SS</sub> output (analogue)

The electrical signals after the differential input of the downstream electronic components. The HIWIN-MAGIC-PG interface sin/cos 1 V<sub>SS</sub> is strictly based on the Siemens

specification. The period length of the sine output signal is 1 mm. The period length of the reference signal is 1 mm.

#### Electrical signals after the difference input of the subsequent electronics (analogue version)

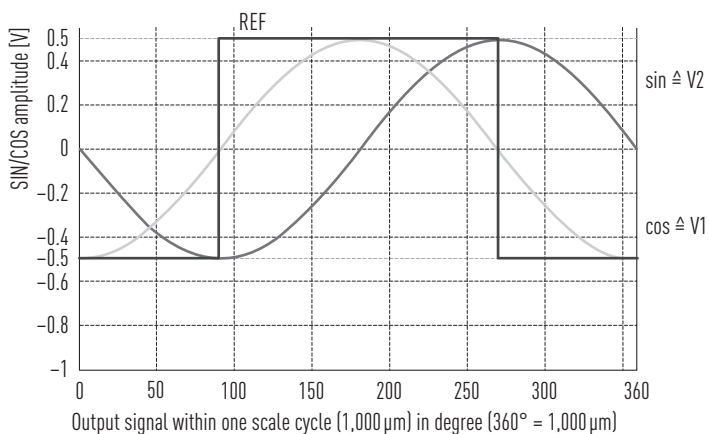

## Recommended downstream electronic circuit with sin/cos-1 V<sub>SS</sub> output

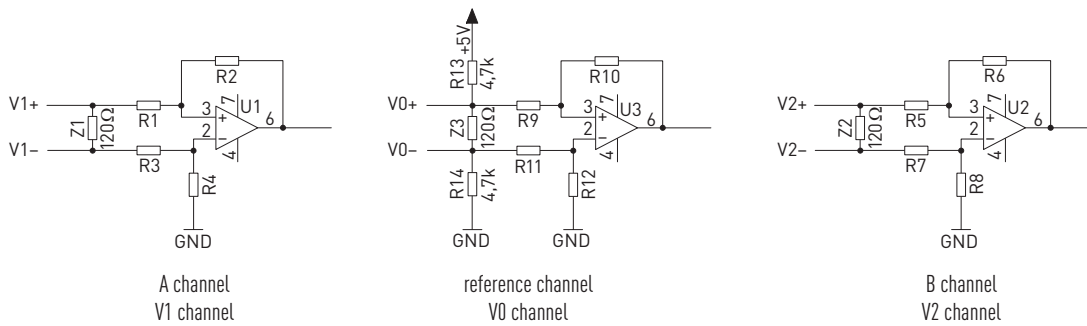

## TTL output (digital)

The signals to the A and B channels phase-shifted by 90° (according to the RS-422 specifications conforming to DIN 66259). Recommended terminating resistance  $Z = 120\ \Omega$ . Output signals: A,  $\bar{A}$ , B,  $\bar{B}$  and Z,  $\bar{Z}$ . Single reference pulse and the definition of a minimum pulse duration are possible as an option.

## Signals of the MAGIC encoder (TTL version)

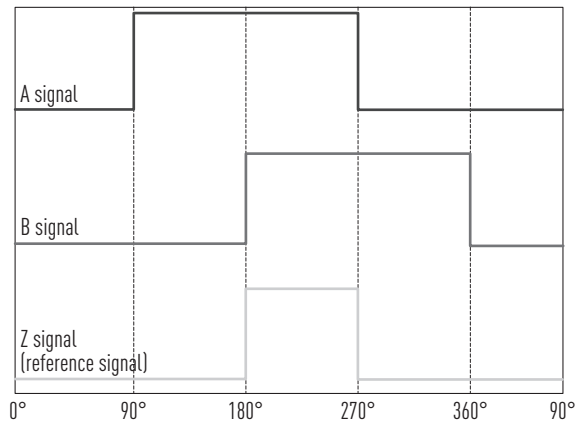

## Recommended switching of the downstream electronic components with digital TTL output

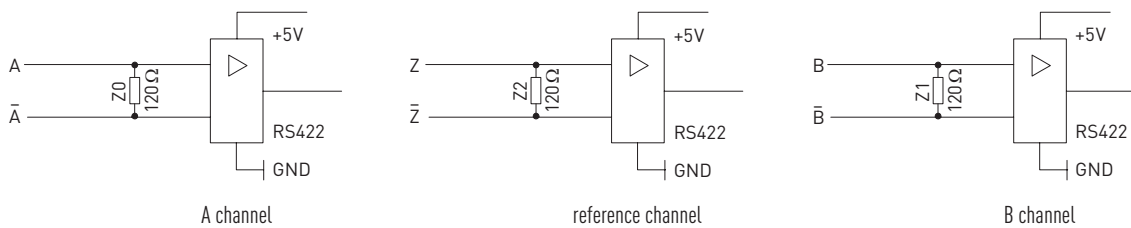

# Linear guideways

## Accessories

### 4. Accessories

#### 4.1 Lubrication adapter

A lubricating nipple is fitted as standard on the end face of one end of the block **(1)**. The opposite side is closed with a plug screw. Alternatively, lubrication can also be supplied via the four holes **(2)** provided in the side of the deflector or from above **(3)**. Lubricating nipples, lubrication adapters or push-in fittings can be used for lubrication.

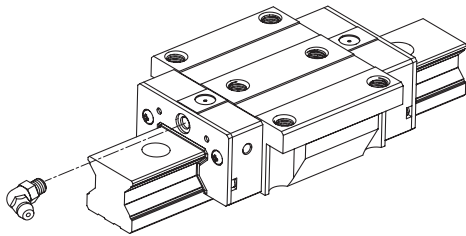

**(1)** Front side lubrication

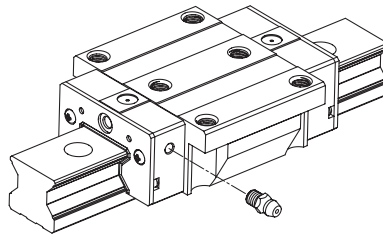

**(2)** Side lubrication

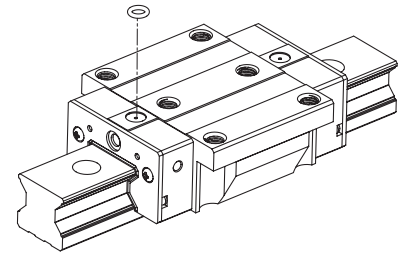

**(3)** Lubrication from above

Table 4.1 Overview of block type/thread size

Block type	Thread size side/front
HG_15	M4
HG_20, HG_25, HG_30, HG_35	M6 × 0.75
HG_45, HG_55, HG_65	1/8 PT
QH_15	M4
QH_20, QH_25, QH_30, QH_35	M6 × 0.75
QH_45	1/8 PT
EG_15	M4
EG_20, EG_25, EG_30, EG_35	M6 × 0.75
QE_15	M4
QE_20, QE_25, QE_30, QE_35	M6 × 0.75
CG_15, CG_20	M3
CG_25, CG_30, CG_35, CG_45	M6 × 0.75
WE_17	M3
WE_21, WE_27, WE_35, QW_21, QW_27	M6 × 0.75 / M4
WE_35, QW_35	M6 × 0.75
WE_50	1/8 PT
MG_15	M3
RG_15, RG_20, CRG_15, CRG_20	M4
RG_25, RG_30, RG_35, CRG_25, CRG_30, CRG_35	M6 × 0.75
RG_45, RG_55, RG_65, CRG_45, CRG_55, CRG_65	1/8 PT
QR_25, QR_30, QR_35	M6 × 0.75
QR_45	1/8 PT

Various grease nipples, lubrication adapters and push-in fittings are available as an option.



Fig. 4.1 Grease nipple

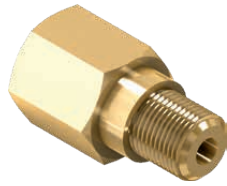

Fig. 4.2 Lubrication adapter



Fig. 4.3 Push-in fitting

Information on the suitable lubrication connector for your block depending on the sealing system (see chapter 2.9) can be found in the grease nipple configurator at [hiwin.de](http://hiwin.de).

## 4.2 Grease guns and lubricants

Table 4.2 HIWIN grease guns

Article number	Grease gun	Lubricating adaptor and nozzle set	Direct filling	Cartridge
20-000352	●	—	●	70 g
20-000332	●	●	●	70 g
20-000353	●	—	●	400 g
20-000333	●	●	●	400 g
20-000358	—	●	—	—

Table 4.3 HIWIN greases

Grease type	Area of application	Article number	
		Cartridge 70 g	Cartridge 400 g
G01	Heavy-duty applications	20-000335	20-000336
G02	Clean room applications	20-000338	20-000339
G03	Clean room applications High velocity	20-000341	20-000342
G04	Heavy velocity	20-000344	20-000345
G05	Standard grease	20-000347	20-000348
G06	Short stroke or high frequency	20-002195	20-002196
G07	Low temperatures	20-002197	20-002198

Table 4.4 HIWIN oils

Article number	Description	Scope	Comment
20-000350	SHC 636	1 litre bottle	Oil for filling long-term lubrication unit tank

Detailed information on HIWIN lubricants and lubrication of the linear guideways can be found in the HIWIN “**Linear guideways**” assembly instructions at [hiwin.de](http://hiwin.de).

# WE LIVE MOTION

All rights reserved.  
Complete or partial reproduction is not permitted  
without our permission.

Note:  
The technical data in this catalogue may be changed  
without prior notice.